

Rexroth Frequency Converter

EFC 3610 / EFC 5610 Series

Operating Instructions
R912005854

Edition 02



Record of Revision

Edition	Release Date	Notes
DOK-RCON03-EFC-X610***-IT01-EN-P	2014.10	First release
DOK-RCON03-EFC-X610***-IT02-EN-P	2014.12	New functions

Version Matching Table

Firmware	Operating Instructions	Quick Start Guide	Finished Product
01V20	Edition 02	Edition 02	AB1

Copyright

© Bosch Rexroth (Xi'an) Electric Drives and Controls Co., Ltd. 2014

This document, as well as the data, specifications and other information set forth in it, are the exclusive property of Bosch Rexroth (Xi'an) Electric Drives and Controls Co., Ltd. It may not be reproduced or given to third parties without its consent.

Liability

The specified data is intended for product description purposes only and shall not be deemed to be a guaranteed characteristic unless expressly stipulated in the contract. All rights are reserved with respect to the content of this documentation and the availability of the product.

D Deutsch	USA English	F Français
<p>⚠️ WARNUNG Lebensgefahr bei Nichtbeachtung der nachstehenden Sicherheitshinweise!</p> <p>Nehmen Sie die Produkte erst dann in Betrieb, nachdem Sie die mit dem Produkt gelieferten Unterlagen und Sicherheitshinweise vollständig durchgelesen, verstanden und beachtet haben.</p> <p>Sollten Ihnen keine Unterlagen in Ihrer Landessprache vorliegen, wenden Sie sich an Ihren zuständigen Rexroth-Vertriebspartner.</p> <p>Nur qualifiziertes Personal darf an Antriebskomponenten arbeiten.</p> <p>Nähere Erläuterungen zu den Sicherheitshinweisen entnehmen Sie Kapitel 1 dieser Dokumentation.</p>	<p>⚠️ WARNING Danger to life in case of non-compliance with the below-mentioned safety instructions!</p> <p>Do not attempt to install or put these products into operation until you have completely read, understood and observed the documents supplied with the product.</p> <p>If no documents in your language were supplied, please consult your Rexroth sales partner.</p> <p>Only qualified persons may work with drive components.</p> <p>For detailed explanations on the safety instructions, see chapter 1 of this documentation.</p>	<p>⚠️ AVERTISSEMENT Danger de mort en cas de non-respect des consignes de sécurité figurant ci-après !</p> <p>Ne mettez les produits en service qu'après avoir lu complètement et après avoir compris et respecté les documents et les consignes de sécurité fournis avec le produit.</p> <p>Si vous ne disposez pas de la documentation dans votre langue, merci de consulter votre partenaire Rexroth.</p> <p>Seul un personnel qualifié est autorisé à travailler sur les composants d'entraînement.</p> <p>Vous trouverez des explications plus détaillées relatives aux consignes de sécurité au chapitre 1 de la présente documentation.</p>
<p>⚠️ WARNUNG Hohe elektrische Spannung! Lebensgefahr durch elektrischen Schlag!</p> <p>Betreiben Sie Antriebskomponenten nur mit fest installiertem Schutzleiter.</p> <p>Schalten Sie vor Zugriff auf Antriebskomponenten die Spannungsversorgung aus.</p> <p>Beachten Sie die Entladezeiten von Kondensatoren.</p>	<p>⚠️ WARNING High electrical voltage! Danger to life by electric shock!</p> <p>Only operate drive components with a permanently installed equipment grounding conductor.</p> <p>Disconnect the power supply before accessing drive components.</p> <p>Observe the discharge times of the capacitors.</p>	<p>⚠️ AVERTISSEMENT Tensions électriques élevées ! Danger de mort par électrocution !</p> <p>N'exploitez les composants d'entraînement que si un conducteur de protection est installé de manière permanente.</p> <p>Avant d'intervenir sur les composants d'entraînement, coupez toujours la tension d'alimentation.</p> <p>Tenez compte des délais de décharge de condensateurs.</p>
<p>⚠️ WARNUNG Gefahrbringende Bewegungen! Lebensgefahr!</p> <p>Halten Sie sich nicht im Bewegungsbereich von Maschinen und Maschinenteilen auf.</p> <p>Verhindern Sie den unbeabsichtigten Zutritt für Personen.</p> <p>Bringen Sie vor dem Zugriff oder Zutritt in den Gefahrenbereich die Antriebe sicher zum Stillstand.</p>	<p>⚠️ WARNING Dangerous movements! Danger to life!</p> <p>Keep free and clear of the ranges of motion of machines and moving machine parts.</p> <p>Prevent personnel from accidentally entering the range of motion of machines.</p> <p>Make sure that the drives are brought to safe standstill before accessing or entering the danger zone.</p>	<p>⚠️ AVERTISSEMENT Mouvements entraînant une situation dangereuse ! Danger de mort !</p> <p>Ne séjournez pas dans la zone de mouvement de machines et de composants de machines.</p> <p>Évitez tout accès accidentel de personnes.</p> <p>Avant toute intervention ou tout accès dans la zone de danger, assurez-vous de l'arrêt préalable de tous les entraînements.</p>

D Deutsch	USA English	F Français
<p>⚠️ WARNUNG Elektromagnetische / magnetische Felder! Gesundheitsgefahr für Personen mit Herzschrittmachern, metallischen Implantaten oder Hörgeräten!</p> <p>Zutritt zu Bereichen, in denen Antriebskomponenten montiert und betrieben werden, ist für oben genannten Personen untersagt bzw. nur nach Rücksprache mit einem Arzt erlaubt.</p>	<p>⚠️ WARNING Electromagnetic / magnetic fields! Health hazard for persons with heart pacemakers, metal implants or hearing aids!</p> <p>The above-mentioned persons are not allowed to enter areas in which drive components are mounted and operated, or rather are only allowed to do this after they consulted a doctor.</p>	<p>⚠️ AVERTISSEMENT Champs électromagnétiques / magnétiques ! Risque pour la santé des porteurs de stimulateurs cardiaques, d'implants métalliques et d'appareils auditifs !</p> <p>L'accès aux zones où sont montés et exploités les composants d'entraînement est interdit aux personnes susmentionnées ou bien ne leur est autorisé qu'après consultation d'un médecin.</p>
<p>⚠️ VORSICHT Heiße Oberflächen (> 60 °C)! Verbrennungsgefahr!</p> <p>Vermeiden Sie das Berühren von metallischen Oberflächen (z. B. Kühlkörpern). Abkühlzeit der Antriebskomponenten einhalten (mind. 15 Minuten).</p>	<p>⚠️ CAUTION Hot surfaces (> 60 °C [140 °F])! Risk of burns!</p> <p>Do not touch metallic surfaces (e.g. heat sinks). Comply with the time required for the drive components to cool down (at least 15 minutes).</p>	<p>⚠️ ATTENTION Surfaces chaudes (> 60 °C)! Risque de brûlure !</p> <p>Évitez de toucher des surfaces métalliques (p. ex. dissipateurs thermiques). Respectez le délai de refroidissement des composants d'entraînement (au moins 15 minutes).</p>
<p>⚠️ VORSICHT Unsachgemäße Handhabung bei Transport und Montage! Verletzungsgefahr!</p> <p>Verwenden Sie geeignete Montage- und Transporteinrichtungen.</p> <p>Benutzen Sie geeignetes Werkzeug und persönliche Schutzausrüstung.</p>	<p>⚠️ CAUTION Improper handling during transport and mounting! Risk of injury!</p> <p>Use suitable equipment for mounting and transport.</p> <p>Use suitable tools and personal protective equipment.</p>	<p>⚠️ ATTENTION Manipulation incorrecte lors du transport et du montage ! Risque de blessure !</p> <p>Utilisez des dispositifs de montage et de transport adéquats.</p> <p>Utilisez des outils appropriés et votre équipement de protection personnel.</p>
<p>⚠️ VORSICHT Unsachgemäße Handhabung von Batterien! Verletzungsgefahr!</p> <p>Versuchen Sie nicht, leere Batterien zu reaktivieren oder aufzuladen (Explosions- und Verätzungsgefahr).</p> <p>Zerlegen oder beschädigen Sie keine Batterien. Werfen Sie Batterien nicht ins Feuer.</p>	<p>⚠️ CAUTION Improper handling of batteries! Risk of injury!</p> <p>Do not attempt to reactivate or recharge low batteries (risk of explosion and chemical burns).</p> <p>Do not dismantle or damage batteries. Do not throw batteries into open flames.</p>	<p>⚠️ ATTENTION Manipulation incorrecte de piles! Risque de blessure!</p> <p>N'essayez pas de réactiver des piles vides ou de les charger (risque d'explosion et de brûlure par acide).</p> <p>Ne désassemblez et n'endommagez pas les piles. Ne jetez pas des piles dans le feu.</p>

E Español	P Português	I Italiano
<p>⚠ ADVERTENCIA ¡Peligro de muerte en caso de no observar las siguientes indicaciones de seguridad!</p> <p>Los productos no se pueden poner en servicio hasta después de haber leído por completo, comprendido y tenido en cuenta la documentación y las advertencias de seguridad que se incluyen en la entrega.</p> <p>Si no dispusiera de documentación en el idioma de su país, dirijase a su distribuidor competente de Rexroth.</p> <p>Solo el personal debidamente cualificado puede trabajar en componentes de accionamiento.</p> <p>Encontrará más detalles sobre las indicaciones de seguridad en el capítulo 1 de esta documentación.</p>	<p>⚠ ATENÇÃO Perigo de vida em caso de inobservância das seguintes instruções de segurança!</p> <p>Utilize apenas os produtos depois de ter lido, compreendido e tomado em consideração a documentação e as instruções de segurança fornecidas juntamente com o produto.</p> <p>Se não tiver disponível a documentação na sua língua, dirija-se ao seu parceiro de venda responsável da Rexroth.</p> <p>Apenas pessoal qualificado pode trabalhar nos componentes de acionamento.</p> <p>Explicações mais detalhadas relativamente às instruções de segurança constam no capítulo 1 desta documentação.</p>	<p>⚠ AVVERTENZA Pericolo di morte in caso di inosservanza delle seguenti indicazioni di sicurezza!</p> <p>Mettere in funzione i prodotti solo dopo aver letto, compreso e osservato per intero la documentazione e le indicazioni di sicurezza fornite con il prodotto.</p> <p>Se non dovesse essere presente la documentazione nella vostra lingua, siete pregati di rivolgervi al rivenditore Rexroth competente.</p> <p>Solo personale qualificato può eseguire lavori sui componenti di comando.</p> <p>Per ulteriori spiegazioni riguardanti le indicazioni di sicurezza consultare il capitolo 1 di questa documentazione.</p>
<p>⚠ ADVERTENCIA ¡Alta tensión eléctrica! ¡Peligro de muerte por descarga eléctrica!</p> <p>Active sólo los componentes de accionamiento con el conductor protector firmemente instalado.</p> <p>Desconecte la alimentación eléctrica antes de manipular los componentes de accionamiento.</p> <p>Tenga en cuenta los tiempos de descarga de los condensadores.</p>	<p>⚠ ATENÇÃO Alta tensão elétrica! Perigo de vida devido a choque elétrico!</p> <p>Opere componentes de accionamento apenas com condutores de proteção instalados.</p> <p>Desligue a alimentação de tensão antes de aceder aos componentes de accionamento.</p> <p>Respeite os períodos de descarga dos condensadores.</p>	<p>⚠ AVVERTENZA Alta tensione elettrica! Pericolo di morte in seguito a scosse elettriche!</p> <p>Mettere in esercizio i componenti di comando solo con conduttore di messa a terra ben installato.</p> <p>Staccare l'alimentazione prima di intervenire sui componenti di comando.</p> <p>Osservare i tempi di scarica del condensatore.</p>
<p>⚠ ADVERTENCIA ¡Movimientos peligrosos! ¡Peligro de muerte!</p> <p>No permanezca en la zona de movimiento de las máquinas ni de sus piezas.</p> <p>Impida el acceso accidental de personas.</p> <p>Antes de acceder o introducir las manos en la zona de peligro, los accionamientos se tienen que haber parado con seguridad.</p>	<p>⚠ ATENÇÃO Movimentos perigosos! Perigo de vida!</p> <p>Não permaneça na área de movimentação das máquinas e das peças das máquinas.</p> <p>Evite o acesso involuntário para pessoas.</p> <p>Antes de entrar ou aceder à área perigosa, imobilize os acionamentos de forma segura.</p>	<p>⚠ AVVERTENZA Movimenti pericolosi! Pericolo di morte!</p> <p>Non sostare nelle zone di manovra delle macchine e delle loro parti.</p> <p>Impedire un accesso non autorizzato per le persone.</p> <p>Prima di accedere alla zona di pericolo, arrestare e bloccare gli azionamenti.</p>

E Español	P Português	I Italiano
<p>⚠ ADVERTENCIA ¡Campos electromagnéticos/magnéticos! ¡Peligro para la salud de las personas con marcapasos, implantes metálicos o audífonos!</p> <p>El acceso de las personas arriba mencionadas a las zonas de montaje o funcionamiento de los componentes de accionamiento está prohibido, salvo que lo autorice previamente un médico.</p>	<p>⚠ ATENÇÃO Campos eletromagnéticos / magnéticos! Perigo de saúde para pessoas com marcapassos, implantes metálicos ou aparelhos auditivos!</p> <p>Acesso às áreas, nas quais os componentes de acionamento são montados e operados, é proibido para as pessoas em cima mencionadas ou apenas após permissão de um médico.</p>	<p>⚠ AVVERTENZA Campi elettromagnetici / magnetici! Pericolo per la salute delle persone portatrici di pacemaker, protesi metalliche o apparecchi acustici!</p> <p>L'accesso alle zone in cui sono installati o in funzione componenti di comando è vietato per le persone sopra citate o consentito solo dopo un colloquio con il medico.</p>
<p>⚠ ATENCIÓN ¡Superficies calientes (> 60 °C)! ¡Peligro de quemaduras!</p> <p>Evite el contacto con las superficies calientes (p. ej., disipadores de calor). Observe el tiempo de enfriamiento de los componentes de accionamiento (mín. 15 minutos).</p>	<p>⚠ CUIDADO Superfícies quentes (> 60 °C)! Perigo de queimaduras!</p> <p>Evite tocar superficies metálicas (p. ex. radiadores). Respeite o tempo de arrefecimento dos componentes de accionamiento (mín. 15 minutos).</p>	<p>⚠ ATTENZIONE Superfici bollenti (> 60 °C)! Pericolo di ustioni!</p> <p>Evitare il contatto con superfici metalliche (ad es. dissipatori di calore). Rispettare i tempi di raffreddamento dei componenti di comando (almeno 15 minuti).</p>
<p>⚠ ATENCIÓN ¡Manipulación inadecuada en el transporte y montaje! ¡Peligro de lesiones!</p> <p>Utilice dispositivos de montaje y de transporte adecuados.</p> <p>Utilice herramientas adecuadas y equipo de protección personal.</p>	<p>⚠ CUIDADO Manejo incorreto no transporte e montagem! Perigo de ferimentos!</p> <p>Utilize dispositivos de montagem e de transporte adequados.</p> <p>Utilize ferramentas e equipamento de proteção individual adequados.</p>	<p>⚠ ATTENZIONE Manipolazione inappropriata durante il trasporto e il montaggio! Pericolo di lesioni!</p> <p>Utilizzare dispositivi di montaggio e trasporto adatti.</p> <p>Utilizzare attrezzi adatti ed equipaggiamento di protezione personale.</p>
<p>⚠ ATENCIÓN ¡Manejo inadecuado de las pilas! ¡Peligro de lesiones!</p> <p>No trate de reactivar o cargar pilas descargadas (peligro de explosión y cauterización).</p> <p>No desarme ni dañe las pilas. No tire las pilas al fuego.</p>	<p>⚠ CUIDADO Manejo incorreto de baterias! Perigo de ferimentos!</p> <p>Não tente reativar nem carregar baterias vazias (perigo de explosão e de queimaduras com ácido).</p> <p>Não desmonte nem danifique as baterias. Não deite as baterias no fogo.</p>	<p>⚠ ATTENZIONE Utilizzo inappropriato delle batterie! Pericolo di lesioni!</p> <p>Non tentare di riattivare o ricaricare batterie scariche (pericolo di esplosione e corrosione).</p> <p>Non scomporre o danneggiare le batterie. Non gettare le batterie nel fuoco.</p>

S Svenska	DK Dansk	NL Nederlands
<p>⚠ VARNING Livsfara om följande säkerhetsanvisningar inte följs!</p> <p>Använd inte produkterna innan du har läst och förstått den dokumentation och de säkerhetsanvisningar som medföljer produkten, och följ alla anvisningar. Kontakta din Rexroth-återförsäljare om dokumentationen inte medföljer på ditt språk.</p> <p>Endast kvalificerad personal får arbeta med drivkomponenterna.</p> <p>Se kapitel 1 i denna dokumentation för närmare beskrivningar av säkerhetsanvisningarna.</p>	<p>⚠ ADVARSEL Livsfare ved manglende overholdelse af nedenstående sikkerhedsanvisninger!</p> <p>Tag ikke produktet i brug, før du har læst og forstået den dokumentation og de sikkerhedsanvisninger, som følger med produktet, og overhold de givne anvisninger.</p> <p>Kontakt din Rexroth-forhandler, hvis dokumentationen ikke medfølger på dit sprog.</p> <p>Det er kun kvalificeret personale, der må arbejde på drive components.</p> <p>Nærmere forklaringer til sikkerhedsanvisningerne fremgår af kapitel 1 i denne dokumentation.</p>	<p>⚠ WAARSCHUWING Levensgevaar bij niet-naleving van onderstaande veiligheidsinstructies!</p> <p>Stel de producten pas in bedrijf nadat u de met het product geleverde documenten en de veiligheidsinformatie volledig gelezen, begrepen en in acht genomen heeft.</p> <p>Mocht u niet beschikken over documenten in uw landstaal, kunt u contact opnemen met uw plaatselijke Rexroth distributiepartner.</p> <p>Uitsluitend gekwalificeerd personeel mag aan de aandrijvingscomponenten werken.</p> <p>Meer informatie over de veiligheidsinstructies vindt u in hoofdstuk 1 van deze documentatie.</p>
<p>⚠ VARNING Hög elektrisk spänning! Livsfara genom elchock!</p> <p>Använd endast drivkomponenterna med fastmonterad skyddsledare.</p> <p>Koppla bort spänningsförsörjningen före arbete på drivkomponenter.</p> <p>Var medveten om kondensatorernas urladdningstid.</p>	<p>⚠ ADVARSEL Elektrisk højspænding! Livsfare på grund af elektrisk stød!</p> <p>Drive components må kun benyttes med et fast installeret jordstik.</p> <p>Sørg for at koble spændingsforsyningen fra, inden du rører ved drive components.</p> <p>Overhold kondensatorernes afladningstider.</p>	<p>⚠ WAARSCHUWING Hoge elektrische spanning! Levensgevaar door elektrische schok!</p> <p>Bedien de aandrijvingscomponenten uitsluitend met vast geïnstalleerde aardleiding.</p> <p>Schakel voor toegang tot aandrijvingscomponenten de spanningsvoorziening uit.</p> <p>Neem de ontladtid van de condensatoren in acht.</p>
<p>⚠ VARNING Farliga rörelser! Livsfara!</p> <p>Uppehåll dig inte inom maskiners och maskindelars rörelseområde.</p> <p>Förhindra att obehöriga personer får tillträde.</p> <p>Innan du börjar arbeta eller vistas inom drivsystemets riskområde måste maskinen vara stillastående.</p>	<p>⚠ ADVARSEL Farlige bevægelser! Livsfare!</p> <p>Du må ikke opholde dig inden for maskiners og maskindeles bevægelsesradius.</p> <p>Sørg for, at ingen personer kan få utilsigtet adgang.</p> <p>Stands drevene helt, inden du rører ved drevene eller træder ind i deres fareområde.</p>	<p>⚠ WAARSCHUWING Risicovolle bewegingen! Levensgevaar!</p> <p>Houdt u niet op in het bewegingsbereik van machines en machineonderdelen.</p> <p>Voorkom dat personen onbedoeld toegang verkrijgen.</p> <p>Voor toegang tot de gevaarlijke zone moeten de aandrijvingen veilig tot stilstand gebracht zijn.</p>

S Svenska	DK Dansk	NL Nederlands
<p>⚠ VARNING Elektromagnetiska/magnetiska fält! Hälsofara för personer med pacemaker, implantat av metall eller hörapparat!</p> <p>Det är förbjudet för ovan nämnda personer (eller kräver överläggning med läkare) att beträda områden där drivkomponenter är monterade och i drift.</p>	<p>⚠ ADVARSEL Elektromagnetiske/magnetiske felter! Sundhedsfare for personer med pacemakere, metalliske implantater eller høreapparater!</p> <p>For disse personer er der adgang forbudt eller kun adgang med tilladelse fra læge til de områder, hvor drive components monteres og drives.</p>	<p>⚠ WAARSCHUWING Elektromagnetische / magnetische velden! Gevaar voor de gezondheid van personen met pacemakers, metalen implantaten of hoorapparaten!</p> <p>Toegang tot gebieden, waarin aandrijvingscomponenten worden gemonteerd en bediend, is verboden voor voornoemde personen of uitsluitend toegestaan na overleg met een arts.</p>
<p>⚠ OBSERVERA Varma ytor (> 60 °C)! Risk för brännskador!</p> <p>Undvik att vidröra metalltytor (t.ex. kylelement). Var medveten om att det tar tid för drivkomponenterna att svalna (minst 15 minuter).</p>	<p>⚠ FORSIGTIG Varme overflader (> 60 °C)! Risiko for forbrændinger!</p> <p>Undgå at berøre metaloverflader (f.eks. køleelementer). Overhold drive components nedkølingstid (min. 15 min.).</p>	<p>⚠ VOORZICHTIG Hete oppervlakken (> 60 °C)! Verbrandingsgevaar!</p> <p>Voorkom contact met metalen oppervlakken (bijv. Koellichamen). Afkoeltijd van de aandrijvingscomponenten in acht nemen (min. 15 minuten).</p>
<p>⚠ OBSERVERA Felaktig hantering vid transport och montering! Skaderisk!</p> <p>Använd passande monterings- och transportanordningar.</p> <p>Använd lämpliga verktyg och personlig skyddsutrustning.</p>	<p>⚠ FORSIGTIG Fejlhåndtering ved transport og montering! Risiko for kvæstelser!</p> <p>Benyt egnede monterings- og transportanordninger.</p> <p>Benyt egnet værktøj og personligt sikkerhedsudstyr.</p>	<p>⚠ VOORZICHTIG Onjuist gebruik bij transport en montage! Letselgevaar!</p> <p>Gebruik geschikte montage- en transportinrichtingen.</p> <p>Gebruik geschikt gereedschap en een persoonlijke veiligheidsuitrusting.</p>
<p>⚠ OBSERVERA Felaktig hantering av batterier! Skaderisk!</p> <p>Försök inte återaktivera eller ladda upp batterier (risk för explosioner och frätskador).</p> <p>Batterierna får inte tas isär eller skadas. Släng inte batterierna i elden.</p>	<p>⚠ FORSIGTIG Fejlhåndtering af batterier! Risiko for kvæstelser!</p> <p>Forsøg ikke at genaktivere eller oplade tomme batterier (eksplosions- og ætsningsfare).</p> <p>Undlad at skille batterier ad eller at beskadige dem. Smid ikke batterier ind i åben ild.</p>	<p>⚠ VOORZICHTIG Onjuist gebruik van batterijen! Letselgevaar!</p> <p>Probeer nooit lege batterijen te reactiveren of op te laden (explosiegevaar en gevaar voor beschadiging van weefsel door cauterisatie).</p> <p>Batterijen niet demonteren of beschadigen. Nooit batterijen in het vuur werpen.</p>

FIN Suomi	PL Polski	CZ Český
<p>VAROITUS Näiden turvaohjeiden noudattamatta jättämisestä on seurauksena hengenvaara!</p> <p>Ota tuote käyttöön vasta sen jälkeen, kun olet lukenut läpi tuotteen mukana toimitetut asiakirjat ja turvallisuusohjeet, ymmärtänyt ne ja ottanut ne huomioon.</p> <p>Jos asiakirjoja ei ole saatavana omalla äidinkiellälläsi, ota yhteyttä asianomaiseen Rexrothin myyntiedustajaan.</p> <p>Käyttölaitteiden komponenttien parissa saa työskennellä ainoastaan valtuutettu henkilöstö.</p> <p>Lisätietoa turvaohjeista löydät tämän dokumentaation luvusta 1.</p>	<p>OSTRZEŻENIE Zagrożenie życia w razie nieprzestrzegania poniższych wskazówek bezpieczeństwa!</p> <p>Nie uruchamiać produktów przed uprzednim przeczytaniem i pełnym zrozumieniem wszystkich dokumentów dostarczonych wraz z produktem oraz wskazówek bezpieczeństwa. Należy przestrzegać wszystkich zawartych tam zaleceń.</p> <p>W przypadku braku dokumentów w Państwa języku, prosimy o skontaktowanie się z lokalnym partnerem handlowym Rexroth.</p> <p>Przy zespołach napędowych może pracować wyłącznie wykwalifikowany personel.</p> <p>Blizsze objaśnienia wskazówek bezpieczeństwa znajdują się w Rozdziale 1 niniejszej dokumentacji.</p>	<p>VAROVÁNÍ Nebezpečí života v případě nedodržení níže uvedených bezpečnostních pokynů!</p> <p>Před uvedením výrobků do provozu si přečtěte kompletní dokumentaci a bezpečnostní pokyny dodané s výrobkem, pochopte je a dodržujte.</p> <p>Nemáte-li k dispozici podklady ve svém jazyce, obraťte se na příslušného obchodního partnera Rexroth.</p> <p>Na komponentách pohonu smí pracovat pouze kvalifikovaný personál.</p> <p>Podrobnější vysvětlení k bezpečnostním pokynům naleznete v kapitole 1 této dokumentace.</p>
<p>VAROITUS Voimakas sähköjännite! Sähköiskun aiheuttama hengenvaara!</p> <p>Käytä käyttölaitteen komponentteja ainoastaan maadoitusjohtimen ollessa kiinteästi asennettuna.</p> <p>Katkaise jännitteensyöttö ennen käyttölaitteen komponenteille suorittettavien töiden aloittamista.</p> <p>Huomioi kondensaattoreiden purkausajat.</p>	<p>OSTRZEŻENIE Wysokie napięcie elektryczne! Zagrożenie życia w wyniku porażenia prądem!</p> <p>Zespoły napędu mogą być eksploatowane wyłącznie z zainstalowanym na stałe przewodem ochronnym.</p> <p>Przed uzyskaniem dostępu do podzespołów napędu należy odłączyć zasilanie elektryczne.</p> <p>Zwracać uwagę na czas rozładowania kondensatorów.</p>	<p>VAROVÁNÍ Vysoké elektrické napětí! Nebezpečí života při zasazení elektrickým proudem!</p> <p>Komponenty pohonu smí být v provozu pouze s pevně nainstalovaným ochranným vodičem.</p> <p>Než začnete zasahovat do komponent pohonu, odpojte je od elektrického napájení.</p> <p>Dodržujte vybíjecí časy kondenzátorů.</p>
<p>VAROITUS Vaarallisia liikkeitä! Hengenvaara!</p> <p>Älä oleskele koneiden tai koneenosien liikealueella.</p> <p>Pidä huolta siitä, ettei muita henkilöitä pääse alueelle vahingossa.</p> <p>Pysäytä käyttölaitteet varmasti ennen vaara-alueelle koskemista tai menemistä.</p>	<p>OSTRZEŻENIE Niebezpieczne ruchy! Zagrożenie życia!</p> <p>Nie wolno przebywać w obszarze pracy maszyny i jej elementów.</p> <p>Nie dopuszczać osób niepowołanych do obszaru pracy maszyny.</p> <p>Przed dotknięciem urządzenia/maszyny lub zbliżeniem się do obszaru zagrożenia należy zgodnie z zasadami bezpieczeństwa wyłączyć napędy.</p>	<p>VAROVÁNÍ Nebezpečné pohyby! Nebezpečí života!</p> <p>Nezdržujte se v dosahu pohybu strojů a jejich součástí.</p> <p>Zabraňte náhodnému přístupu osob.</p> <p>Před zásahem nebo vstupem do nebezpečného prostoru bezpečně zastavte pohony.</p>

 Suomi	 Polski	 Český
<p>VAROITUS Sähkömagneettisia/magneettisia kenttiä! Terveydellisten haittojen vaara henkilöille, joilla on sydämentahdistin, metallinen implantti tai kuulolaite!</p> <p>Yllä mainituilta henkilöiltä on pääsy kielletty alueille, joilla asennetaan tai käytetään käyttölaitteen komponentteja, tai heidän on ensin saatava tähän suostumus lääkäritään.</p>	<p>OSTRZEŻENIE Pola elektromagnetyczne / magnetyczne! Zagrożenie zdrowia dla osób z rozrusznikiem serca, metalowymi implantami lub aparatami słuchowymi!</p> <p>Wstęp na teren, gdzie odbywa się montaż i eksploatacja napędów jest dla ww. osób zabroniony względnie dozwolony po konsultacji z lekarzem.</p>	<p>VAROVÁNÍ Elektromagnetická/magnetická pole! Nebezpečí pro zdraví osob s kardiostimulátory, kovovými implantáty nebo naslouchadly!</p> <p>Výše uvedené osoby mají zakázán přístup do prostorů, kde jsou montovány a používány komponenty pohonu, resp. ho mají povolen pouze po poradě s lékařem.</p>
<p>HUOMIO Kuumia pintoja (> 60 °C)! Palovammojen vaara!</p> <p>Vältä metallipintojen koskettamista (esim. jäähdytyslevyt). Noudata käyttölaitteen komponenttien jäähtymisaikoa (väh. 15 minuuttia).</p>	<p>PRZESTROGA Gorące powierzchnie (> 60 °C)! Niebezpieczeństwo poparzenia!</p> <p>Unikać kontaktu z powierzchniami metalowymi (np. radiatorami). Przestrzegać czasów schładzania podzespołów napędów (min. 15 minut).</p>	<p>UPOZORNĚNÍ Horké povrchy (> 60 °C)! Nebezpečí popálení!</p> <p>Nedotýkejte se kovových povrchů (např. chladičích těles). Dodržujte dobu ochlazení komponent pohonu (min. 15 minut).</p>
<p>HUOMIO Epäasianmukainen käsittely kuljetuksen ja asennuksen yhteydessä! Loukkaantumiswaara!</p> <p>Käytä soveltuvia asennus- ja kuljetuslaitteita.</p> <p>Käytä omia työkaluja ja henkilökohtaisia suojavarusteita.</p>	<p>PRZESTROGA Niewłaściwe obchodzenie się podczas transportu i montażu! Ryzyko urazu!</p> <p>Stosować odpowiednie urządzenia montażowe i transportowe.</p> <p>Stosować odpowiednie narzędzia i środki ochrony osobistej.</p>	<p>UPOZORNĚNÍ Nesprávné zacházení při přepravě a montáži! Nebezpečí zranění!</p> <p>Používejte vhodná montážní a dopravní zařízení.</p> <p>Používejte vhodné nářadí a osobní ochranné vybavení.</p>
<p>HUOMIO Paristojen epäasianmukainen käsittely! Loukkaantumiswaara!</p> <p>Älä yritä saada tyhjiä paristoja toimimaan tai ladata niitä uudelleen (räjähdys- ja syöpymiswaara).</p> <p>Älä hajota paristoja osiin tai vaurioita niitä. Älä heitä paristoja tuelle.</p>	<p>PRZESTROGA Niewłaściwe obchodzenie się z bateriami! Ryzyko urazu!</p> <p>Nie próbować reaktywować i nie ładować zużytych baterii (niebezpieczeństwo wybuchu oraz poparzenia żrącą substancją).</p> <p>Nie demontować i nie niszczyć baterii. Nie wrzucać baterii do ognia.</p>	<p>UPOZORNĚNÍ Nesprávné zacházení s bateriemi! Nebezpečí zranění!</p> <p>Nepokoušejte se znovu aktivovat nebo dobíjet prázdné baterie (nebezpečí výbuchu a poleptání).</p> <p>Nerozebírejte ani nepoškozujte baterie. Neházejte baterie do ohně.</p>

SLO Slovensko	SK Slovenčina	RO Română
<p>⚠ OPOZORILO Življenjska nevarnost pri neupoštevanju naslednjih napotkov za varnost!</p> <p>Izdelke začnite uporabljati šele, ko v celoti preberete, razumete in upošteвате izdelkom priloženo dokumentacijo in varnostne napotke.</p> <p>Če priložena dokumentacija ni na voljo v vašem maternem jeziku, se obrnite na pristojnega distributerja Rexroth.</p> <p>Samo kvalificirano osebje sme delati na pogonskih komponentah.</p> <p>Podrobnejša pojasnila o varnostnih navodilih najdete v poglavju 1 v tej dokumentaciji.</p>	<p>⚠ VAROVANIE Nebezpečnostv ohrozenia života pri nedodržavaní nasledujúcich bezpečnostných pokynov!</p> <p>Výrobky uvádzajte do prevádzky až potom, čo ste úplne prečítali, pochopili a zobrali do úvahy podklady a bezpečnostné pokyny dodané s výrobkom.</p> <p>Ak by ste nemali k dispozícii žiadne podklady v jazyku svojej krajiny, obráťte sa prosím na svojho príslušného predajcu Rexroth.</p> <p>Na komponentoch pohonu smie pracovať iba kvalifikovaný personál.</p> <p>Bližšie vysvetlenia k bezpečnostným pokynom zistíte z kapitoly 1 tejto dokumentácie.</p>	<p>⚠ AVERTIZARE Pericol de moarte în cazul nerespectării următoarelor instrucțiuni de siguranță!</p> <p>Punerea în funcțiune a produselor trebuie efectuată după citirea, înțelegerea și respectarea documentelor și instrucțiunilor de siguranță, care sunt livrate împreună cu produsele.</p> <p>În cazul în care documentele nu sunt în limba dumneavoastră maternă, vă rugăm să contactați partenerul de vânzări Rexroth.</p> <p>Numai un personal calificat poate lucra cu componentele de acționare.</p> <p>Explicații detaliate privind instrucțiunile de siguranță găsiți în capitolul 1 al acestei documentații.</p>
<p>⚠ OPOZORILO Visoka električna napetost! Življenjska nevarnost zaradi električnega udara!</p> <p>Pogonske komponente uporabljajte samo s fiksno nameščenim zaščitnim vodnikom.</p> <p>Pred dostopom do pogonske komponente odklopite napajanje.</p> <p>Upošteвайте čase praznjenja kondenzatorjev.</p>	<p>⚠ VAROVANIE Vysoké elektrické napätie! Nebezpečnostv ohrozenia života v dôsledku zásahu elektrickým prúdom!</p> <p>Komponenty pohonu prevádzkujte iba s pevne nainštalovaným ochranným vodičom.</p> <p>Pred prístupom na komponenty pohonu odpojte zdroj napätia.</p> <p>Rešpektujte časy vybitia kondenzátorov.</p>	<p>⚠ AVERTIZARE Tensiune electrică înaltă! Pericol de moarte prin electrocutare!</p> <p>Exploatați componentele de acționare numai cu împământarea instalată permanent.</p> <p>Înainte de intervenția asupra componentelor de acționare, deconectați alimentarea cu tensiune electrică.</p> <p>Țineți cont de timpii de descărcare ai condensatorilor.</p>
<p>⚠ OPOZORILO Nevarni premiki! Življenjska nevarnost!</p> <p>Ne zdržujte se v območju delovanja strojev.</p> <p>Preprečite nenadzorovan dostop oseb.</p> <p>Pred prijemom ali dostopom v nevarno območje varno zaustavite vse gnane dele.</p>	<p>⚠ VAROVANIE Pohyby prinášajúce nebezpečnostv! Nebezpečnostv ohrozenia života!</p> <p>Nezdrživajte sa v oblasti pohybu strojov a častí strojov.</p> <p>Zabráňte nepovolanému prístupu osôb.</p> <p>Pred zásahom alebo prístupom do nebezpečnej oblasti uveďte pohony bezpečne do zastavenia.</p>	<p>⚠ AVERTIZARE Mișcări periculoase! Pericol de moarte!</p> <p>Nu staționați în zona de mișcare a mașinilor și a componentelor în mișcare a mașinilor.</p> <p>Împiedicați accesul neintenționat al persoanelor în zona de lucru a mașinilor.</p> <p>Înainte de intervenția sau accesul în zona periculoasă, opriți în siguranță componentele de acționare.</p>

SLO Slovensko	SK Slovenčina	RO Română
<p>⚠ OPOZORILO Elektromagnetna / magnetna polja! Nevarnost za zdravje za osebe s spodbujevalniki srca, kovinskimi vsadki ali slušnimi aparati!</p> <p>Dostop do območij, v katerih so nameščene delujoče pogonske komponente, je za zgoraj navedene osebe prepovedan oz. dovoljen samo po posvetu z zdravnikom.</p>	<p>⚠ VAROVANIE Elektromagnetické/magnetické polia! Nebezpečnosť pre zdravie osôb s kardiostimulátormi, kovovými implantátmi alebo načúvacími prístrojmi!</p> <p>Prístup k oblastiam, v ktorých sú namontované a prevádzkujú sa komponenty pohonu, je pre hore uvedené osoby zakázaný resp. je dovolený iba po konzultácii s lekárom.</p>	<p>⚠ AVERTIZARE Câmpuri electromagnetice / magnetice! Pericol pentru sănătatea persoanelor cu stimulatori cardiace, implanturi metalice sau aparate auditive!</p> <p>Intrarea în zone, în care se montează sau se exploatează componente de acționare, este interzisă pentru persoanele sus numite respectiv este permisă numai cu acordul medicului.</p>
<p>⚠ POZOR Vročje površine (> 60 °C)! Nevarnost opeklin!</p> <p>Izogibajte se stiku s kovinskimi površinami (npr. hladilnimi telesmi). Upoštevajte čas hlajenja pogonskih komponent (najm. 15 minut).</p>	<p>⚠ UPOZORNENIE Horúce povrchy (> 60 °C)! Nebezpečnosť popálenia!</p> <p>Zabráňte kontaktu s kovovými povrchmi (napr. chladiacimi telesami). Dodržiavajte čas vychladenia komponentov pohonu (min. 15 minút).</p>	<p>⚠ ATENȚIE Suprafețe fierbinți (> 60 °C)! Pericol de arsuri!</p> <p>Nu atingeți suprafețele metalice (de ex. radiatoare de răcire). Respectați timpii de răcire ai componentelor de acționare (min. 15 minute).</p>
<p>⚠ POZOR Nestrokovno ravnanje med transportom in namestitvijo! Nevarnost poškodb!</p> <p>Uporablajte ustrezne pripomočke za nameščanje in transport.</p> <p>Uporabite ustrezno orodje in osebno zaščitno opremo.</p>	<p>⚠ UPOZORNENIE Neodborná manipulácia pri transporte a montáži! Nebezpečnosť poranenia!</p> <p>Používajte vhodné montážne a transportné zariadenia.</p> <p>Používajte vhodné náradie a osobné ochranné prostriedky.</p>	<p>⚠ ATENȚIE Manipulare necorespunzătoare la transport și montaj! Pericol de vătămare!</p> <p>Utilizați dispozitive adecvate de montaj și transport.</p> <p>Folosii instrumente corespunzătoare și echipament personal de protecție.</p>
<p>⚠ POZOR Nepravilno ravnanje z baterijami! Nevarnost poškodb!</p> <p>Ne poskušajte ponovno aktivirati ali napolniti praznih baterij (Nevarnost zaradi eksplozij ali jedkanja).</p> <p>Ne razstavljajte ali poškodujte nobenih baterij. Baterij ne mečite v ogenj.</p>	<p>⚠ UPOZORNENIE Neodborná manipulácia s batériami! Nebezpečnosť poranenia!</p> <p>Nepokúšajte sa reaktivovať alebo nabíjať prázdne batérie (nebezpečnosť výbuchu a poleptania).</p> <p>Batérie nerozoberajte ani nepoškodujte. Nehádzte batérie do ohňa.</p>	<p>⚠ ATENȚIE Manipulare necorespunzătoare a bateriilor! Pericol de vătămare!</p> <p>Nu încercați să reactivați sau să încărcăți bateriile goale (pericol de explozie și pericol de arsuri).</p> <p>Nu dezasamblați și nu deteriorați bateriile. Nu aruncați bateriile în foc.</p>

H Magyar	BG Български	LV Latviski
<p>▲ FIGYELMEZTETÉS! Az alábbi biztonsági útmutatások figyelmen kívül hagyása életveszélyes helyzethez vezethet!</p> <p>Üzembe helyezés előtt olvassa el, értelmezze, és vegye figyelembe a csomagban található dokumentumban foglaltakat és a biztonsági útmutatásokat.</p> <p>Amennyiben a csomagban nem talál az Ön nyelvén írt dokumentumokat, vegye fel a kapcsolatot az illetékes Rexroth-képviselővel.</p> <p>A hajtás alkatrészein kizárólag képzett személy dolgozhat.</p> <p>A biztonsági útmutatókkal kapcsolatban további magyarázatot ennek a dokumentumnak az első fejezetében találhat.</p>	<p>▲ ПРЕДУПРЕЖДЕНИЕ</p> <p>Опасност за живота при неспазване на посочените по-долу инструкции за безопасност!</p> <p>Използвайте продуктите след като сте се запознали подробно с приложената към продукта документация и указания за безопасност, разбрали сте ги и сте се съобразили с тях.</p> <p>Ако текстът не е написан на Вашия език, моля обърнете се към Вашия компетентен търговски представител на Rexroth.</p> <p>Със задвижващите компоненти трябва да работи само квалифициран персонал.</p> <p>Подробни пояснения към инструкциите за безопасност можете да видите в Глава 1 на тази документация.</p>	<p>▲ BRĪDINĀJUMS Turpinājumā doto drošības norādījumu neievērošana var apdraudēt dzīvību!</p> <p>Sāciet lietot izstrādājumu tikai pēc tam, kad esat pilnībā izlasījuši, sapratuši un nēmuši vērā kopā ar izstrādājumu piegādātos dokumentus.</p> <p>Ja dokumenti nav pieejami Jūsu valsts valodā, vērsieties pie pilnvarotā Rexroth izplatītāja.</p> <p>Darbus pie piedziņas komponentiem drīkst veikt tikai kvalificēts personāls.</p> <p>Detalizētus paskaidrojumus attiecībā uz drošības norādījumiem skatiet šī dokumenta 1. nodaļā.</p>
<p>▲ FIGYELMEZTETÉS! Magas elektromos feszültség! Életveszély áramütés miatt!</p> <p>A hajtás alkatrészeit csak véglegesen telepített védővezetővel üzemeltesse!</p> <p>Mielőtt hozzányúl a hajtás alkatrészeihez, kapcsolja ki az áramellátást.</p> <p>Ügyeljen a kondenzátorok kisülési idejére!</p>	<p>▲ ПРЕДУПРЕЖДЕНИЕ Високо електрическо напрежение! Опасност за живота от удар от електрически ток!</p> <p>Работете със задвижващите компоненти само при здраво закрепен заземяващ проводник.</p> <p>Преди работа по задвижващите компоненти, изключете захранващото напрежение.</p> <p>Обърнете внимание на времето за разреждане на кондензаторите.</p>	<p>▲ BRĪDINĀJUMS Augsts elektriskais spriegums! Dzīvības apdraudējums elektriskā trieciena dēļ!</p> <p>Piedziņas komponentus darbiniet tikai ar fiksēti uzstādītu zemējumvadu.</p> <p>Pirms darba pie piedziņas komponentiem atslēdziet elektroapgādi.</p> <p>Nemiet vērā kondensatoru izlādes laikus.</p>
<p>▲ FIGYELMEZTETÉS! Veszélyes mozgás! Életveszély!</p> <p>Ne tartózkodjon a gépek és a gépalkatrészek mozgási területén belül!</p> <p>Illetéktelen személyeket ne engedjen a gép közelébe!</p> <p>Mielőtt beavatkozik, vagy a veszélyes zónába belép a hajtásokat biztonságosan állítsa le.</p>	<p>▲ ПРЕДУПРЕЖДЕНИЕ Опасни движения! Опасност за живота!</p> <p>Не стойте в обсега на движение на машините и частите на машините.</p> <p>Не допускайте непреднамерен достъп на хора.</p> <p>Преди работа или влизане в опасната зона, спрете наредно приводиния механизъм.</p>	<p>▲ BRĪDINĀJUMS Bīstamas kustības! Dzīvības apdraudējums!</p> <p>Neuzturieties mašīnu un mašīnas detaļu kustību zonā.</p> <p>Novērsiet nepiederošu personu piekļūšanu.</p> <p>Pirms darba bīstamajās zonās pilnībā apstādiniet piedziņu.</p>

H Magyar	BG Български	LV Latviski
<p>▲ FIGYELMEZTETÉS! Elektromágneses / mágneses mező! Káros hatással lehet a szívritmus-szabályozó készülékekkel, fémbeültetéssel vagy hallókészülékkel rendelkezők egészségére!</p> <p>Azokra a területekre, ahol hajtások alkatrészeit szerelik és üzemeltetik, a fent említett személyeknek tilos a belépés, illetve csak orvosi konzultációt követően szabad az adott területekre lépniük.</p>	<p>▲ ПРЕДУПРЕЖДЕНИЕ Електромагнитни / магнитни полета! Опасност за здравето на хора със сърдечни стимулатори, метални импланти или слухови апарати!</p> <p>Достъпът за гореспоменатите лица до зони, в които ще се монтира и ще работят задвижващи компоненти се забранява, или разрешава само след консултация с лекар.</p>	<p>▲ BRĪDINĀJUMS Elektromagnētiskais / magnētiskais lauks! Veselības apdraudējums personām ar sirds stimulatoriem, metāliskiem implantiem vai dzirdes aparātiem!</p> <p>Tuvošanās zonām, kurās tiek montēti un darbināti piedziņas komponenti, iepriekš minētajām personām ir aizliegta, respektīvi, atļauta tikai pēc konsultēšanās ar ārstu.</p>
<p>▲ VIGYÁZAT! Forró felületek (> 60 °C)! Égésveszély!</p> <p>Ne érjen hozzá fémfelületekhez (pl. hűtőtestekhez)! Vegye figyelembe a hajtás alkatrészeinek kihűlési idejét (min. 15 perc)!</p>	<p>▲ ВНИМАНИЕ Горещи повърхности (> 60 °C)! Опасност от изгаряне!</p> <p>Не докосвайте метални повърхности (например радиатори). Съблюдавайте времето на охлаждане на задвижващите компоненти (мин. 15 минути).</p>	<p>▲ UZMANĪBU Karstas virsmas (> 60 °C)! Apdedzināšanās risks!</p> <p>Neskarieties pie metāliskām virsmām (piemēram, dzesētāja). Ļaujiet piedziņas komponentiem atdzist (min. 15 minūtes).</p>
<p>▲ VIGYÁZAT! Szakszerűtlen kezelés szállításkor és szereléskor! Sérülésveszély!</p> <p>A megfelelő beszerelési és szállítási eljárásokat alkalmazza!</p> <p>Használjon megfelelő szerszámokat és személyes védőfelszerelést!</p>	<p>▲ ВНИМАНИЕ Неправилно боравене по време на транспорт и монтаж! Опасност от нараняване!</p> <p>Използвайте подходящо монтажно и транспортно оборудване.</p> <p>Използвайте подходящи инструменти и лични предпазни средства.</p>	<p>▲ UZMANĪBU Nepareizi veikta transportēšana un montāža! Traumu gūšanas risks!</p> <p>Izmantojiet piemērotas montāžas un transportēšanas ierīces.</p> <p>Izmantojiet piemērotus instrumentus un individuālos aizsardzības līdzekļus.</p>
<p>▲ VIGYÁZAT! Akkumulátorok szakszerűtlen kezelése! Sérülésveszély!</p> <p>Üres akkumulátorokat ne aktiváljon újra, illetve ne töltsön fel (robbanás-és marásveszély)!</p> <p>Az akkumulátorokat ne szedje szét, és ne rongálja meg! Az akkumulátort ne dobja tűzbe!</p>	<p>▲ ВНИМАНИЕ Неправилно боравене с батерии! Опасност от нараняване!</p> <p>Не се опитвайте да активирате отново или да зареждате разреждени батерии (Опасност от експлозия и напръскване с агресивен агент).</p> <p>Не разглобявайте и не повреждайте батерии. Не хвърляйте батерии в огън.</p>	<p>▲ UZMANĪBU Nepareiza bateriju lietošana! Traumu gūšanas risks!</p> <p>Nemēģiniet no jauna aktivizēt vai uzlādēt tukšas baterijas (eksplodējuma un ķīmisko apdegumu draudi).</p> <p>Neizjauciet un nesabojājiet baterijas. Nemetiet baterijas uguni.</p>

LT Lietuviškai	EST Eesti	GR Ελληνικά
<p>▲ ISPĖJIMAS Pavojus gyvybei nesilaikant toliau pateikiamų saugumo nurodymų!</p> <p>Naudokite gaminį tik kruopščiai perskaitę prie jo pridėtus aprašus, saugumo nurodymus. Susipažinkite su jais ir vadovaukitės naudodami gaminį.</p> <p>Jei Jūs negavote aprašo gimtąja kalba, kreipkitės į įgaliotus Rexroth atstovus.</p> <p>Prie pavaros komponentų leidžiama dirbti tik kvalifikuotam personalui.</p> <p>Išsamesnius saugumo nurodymų paaiškinimus rasite šios dokumentacijos 1 skyriuje.</p>	<p>▲ HOIATUS Alljärgnevate ohutusjuhiste eiramine on eluohhtlik!</p> <p>Võtke tooted käiku alles siis, kui olete toodetega kaasasolevad materjalid ning ohutusjuhised täielikult läbi lugenud, neist aru saanud ja neid järginud.</p> <p>Kui Teil puuduvad emakeelsed materjalid, siis pöörduge Rexrothi kohaliku müügiesinduse poole.</p> <p>Ajamikomponentidega tohib töötada üksnes kvalifitseeritud personal.</p> <p>Täpsemaid selgitusi ohutusjuhiste kohta leiate käesoleva dokumentatsiooni peatükist 1.</p>	<p>▲ ΠΡΟΕΙΔΟΠΟΙΗΣΗ Κίνδυνος θανάτου σε περίπτωση μη συμμόρφωσης με τις παρακάτω οδηγίες ασφαλείας!</p> <p>Θέστε το προϊόν σε λειτουργία αφού διαβάσετε, κατανοήσετε και λάβετε υπόψη το σύνολο των οδηγιών ασφαλείας που το συνοδεύουν.</p> <p>Εάν δεν υπάρχει τεκμηρίωση στη γλώσσα σας, απευθυνθείτε σε εξουσιοδοτημένο αντιπρόσωπο της Rexroth.</p> <p>Μόνο εξειδικευμένο προσωπικό επιτρέπεται να χειρίζεται στοιχεία μετάδοσης κίνησης.</p> <p>Περαιτέρω επεξηγήσεις των οδηγιών ασφαλείας διατίθενται στο κεφάλαιο 1 της παρούσας τεκμηρίωσης.</p>
<p>▲ ISPĖJIMAS Aukšta elektros įtampa! Pavojus gyvybei dėl elektros smūgio!</p> <p>Pavaros komponentus eksploatuokite tik su fiksuotai instaliuotu apsauginiu laidu.</p> <p>Prieš priedami prie pavaros komponentų išjunkite maitinimo įtampą.</p> <p>Atsižvelkite į kondensatorių išsikrovimo trukmę.</p>	<p>▲ HOIATUS Kõrge elektripingel! Eluohhtlik elektrilõõgi tõttu!</p> <p>Käitage ajamikomponente üksnes püsivalt installeeritud maandusega.</p> <p>Lülitage enne ajamikomponentidega tööd teostamist toitepinge välja.</p> <p>Järgige kondensaatorite mahalaadumisaegu.</p>	<p>▲ ΠΡΟΕΙΔΟΠΟΙΗΣΗ Υψηλή ηλεκτρική τάση! Κίνδυνος θανάτου από ηλεκτροπληξία!</p> <p>Θέτετε σε λειτουργία τα στοιχεία μετάδοσης κίνησης μόνο εφόσον έχει τοποθετηθεί καλά προστατευτικός αγωγός γείωσης.</p> <p>Πριν από οποιαδήποτε παρέμβαση, αποσυνδέστε την τροφοδοσία των στοιχείων μετάδοσης κίνησης.</p> <p>Λάβετε υπόψη τους χρόνους αποφόρτισης των πυκνωτών.</p>
<p>▲ ISPĖJIMAS Pavojingi judesiai! Pavojus gyvybei!</p> <p>Nebūkite mašinų ar jų dalių judėjimo zonoje.</p> <p>Neleiskite netyčia patekti asmenims.</p> <p>Prieš patekdami į pavojaus zoną saugiai išjunkite pavaras.</p>	<p>▲ HOIATUS Ohtlikud liikumised! Eluohhtlik!</p> <p>Ärge viibige masina ja masinaosade liikumispiirkonnas.</p> <p>Tõkestage inimeste ettekavatsematu sisenemine masina ja masinaosade liikumispiirkonda.</p> <p>Tagage ajamite turvaline seiskamine enne ohupiirkonda juurdepääsu või sisenemist.</p>	<p>▲ ΠΡΟΕΙΔΟΠΟΙΗΣΗ Επικίνδυνες τάσεις! Κίνδυνος θανάτου!</p> <p>Μην στέκεστε στην περιοχή κίνησης μηχανημάτων και εξαρτημάτων.</p> <p>Αποτρέπετε την τυχαία είσοδο ατόμων.</p> <p>Πριν από την παρέμβαση ή πρόσβαση στην περιοχή κινδύνου, μεριμνήστε για την ασφαλή ακινητοποίηση των συστημάτων μετάδοσης κίνησης.</p>

LT Lietuviškai	EST Eesti	GR Ελληνικά
<p>▲ JSPĒJIMAS Elektromagnetiniai / magnetiniai laukai! Pavojus asmenų su širdies stimulatoriais, metaliniais implantais arba klausos aparatais sveikatai!</p> <p>Prieiga prie zonų, kuriose montuojami ir eksploatuojami pavaros komponentai, aukščiau nurodytiems asmenims yra draudžiama arba leistina tik pasitarus su gydytoju.</p>	<p>▲ HOIATUS Elektromagnetilised / magnetilised väljad! Terviseohtlik südamestimulaatorite, metallimplantaatide ja kuulimisseadmetega inimestele!</p> <p>Sisenemine piirkondadesse, kus toimub ajamikomponentide monteerimine ja käitamine, on ülalnimetatud isikutele keelatud või lubatud üksnes pärast arstiga konsulteerimist.</p>	<p>▲ ΠΡΟΕΙΔΟΠΟΙΗΣΗ Ηλεκτρομαγνητικά/μαγνητικά πεδία! Κίνδυνος για την υγεία ατόμων με καρδιακούς βηματοδότες, μεταλλικά εμφυτεύματα ή συσκευές ακοής!</p> <p>Η είσοδος σε περιοχές όπου πραγματοποιείται συναρμολόγηση και λειτουργία στοιχείων μετάδοσης κίνησης απαγορεύεται στα προαναφερθέντα άτομα, εκτός αν τους έχει δοθεί σχετική άδεια κατόπιν συνεννόησης με γιατρό.</p>
<p>▲ PERSPĒJIMAS Karšti paviršiai (> 60 °C)! Nudegimo pavojus!</p> <p>Venkite liesti metalinius paviršius (pvz., radiatorių). Išlaikykite pavaros komponentų atvėsimo trukmę (bent 15 minučių).</p>	<p>▲ ETTEVAATUST Kuumad välispinnad (> 60 °C)! Põletusoht!</p> <p>Vältige metalsete välispindade (nt radiaatorid) puudutamist. Pidage kinni ajamikomponentide mahajahtumisajast (vähemalt 15 minutit).</p>	<p>▲ ΠΡΟΣΟΧΗ Καυτές επιφάνειες (> 60 °C)! Κίνδυνος εγκαύματος!</p> <p>Αποφεύγετε την επαφή με μεταλλικές επιφάνειες (π.χ. μονάδες ψύξης). Λάβετε υπόψη το χρόνο ψύξης των στοιχείων μετάδοσης κίνησης (τουλάχιστον 15 λεπτά).</p>
<p>▲ PERSPĒJIMAS Netinkamas darbas transportuojant ir montuojant! Susižalojimo pavojus!</p> <p>Naudokite tinkamus montavimo ir transportavimo įrenginius.</p> <p>Naudokite tinkamus įrankius ir asmens saugos priemones.</p>	<p>▲ ETTEVAATUST Asjatundmatu käsitsemine transportimisel ja montaažil! Vigastusoht!</p> <p>Kasutage sobivaid montaaži- ja transpordiseadiseid.</p> <p>Kasutage sobivaid tööriistu ja isiklikku kaitsevarustust.</p>	<p>▲ ΠΡΟΣΟΧΗ Ακατάλληλος χειρισμός κατά τη μεταφορά και συναρμολόγηση! Κίνδυνος τραυματισμού!</p> <p>Χρησιμοποιείτε κατάλληλους μηχανισμούς συναρμολόγησης και μεταφοράς.</p> <p>Χρησιμοποιείτε κατάλληλα εργαλεία και ατομικό εξοπλισμό προστασίας.</p>
<p>▲ PERSPĒJIMAS Netinkamas darbas su baterijomis! Susižalojimo pavojus!</p> <p>Nebandykite tuščių baterijų reaktyvuoti arba įkrauti (sprogimo ir išėsdinimo pavojus).</p> <p>Neardykite ir nepažeiskite baterijų. Nemeskite baterijų į ugnį.</p>	<p>▲ ETTEVAATUST Patareide asjatundmatu käsitsemine! Vigastusoht!</p> <p>Ärge üritage kunagi tühje patareisid reaktiveerida või täis laadida (plahvatus- ja söövitusoht).</p> <p>Ärge demonteerige ega kahjustage patareisid. Ärge visake patareisid tulle.</p>	<p>▲ ΠΡΟΣΟΧΗ Ακατάλληλος χειρισμός μπαταριών! Κίνδυνος τραυματισμού!</p> <p>Μην επιδιώκετε να ενεργοποιήσετε ξανά ή να φορτίσετε κενές μπαταρίες (κίνδυνος έκρηξης και διάβρωσης).</p> <p>Μην διαλύετε ή καταστρέφετε τις μπαταρίες. Μην απορρίπτετε τις μπαταρίες στη φωτιά.</p>

CN 中文

警告 如果不按照下述指定的安全说明使用，将会导致人身伤害！

在没有阅读，理解随本产品附带的文件并熟知正当使用前，不要安装或使用本产品。

如果没有您所在国家官方语言文件说明，请与 Rexroth 销售伙伴联系。

只允许有资格人员对驱动器部件进行操作。

安全说明的详细解释在本文档的第一章。

警告 高压！电击导致生命危险！

只有在安装了永久良好的设备接地导线后才可以对驱动器的部件进行操作。

在接触驱动器部件前先将驱动器部件断电。

确保电容放电时间。

警告 危险运动！生命危险！

保证设备的运动区域内和移动部件周围无障碍物。

防止人员意外进入设备运动区域内。

在接近或进入危险区域之前，确保传动设备安全停止。

警告 电磁场/磁场！对佩戴心脏起搏器、金属植入物和助听器的人员会造成严重的人身伤害！

上述人员禁止进入安装及运行的驱动器区域，或者必须先咨询医生。

小心 热表面（大于 60 度）！灼伤风险！

不要触摸金属表面（例如散热器）。驱动器部件断电后需要时间进行冷却（至少 15 分钟）。

小心 安装和运输不当导致受伤危险！当心受伤！

使用适当的运输和安装设备。

使用适合的工具及用适当的防护设备。

小心 电池操作不当！受伤风险！

请勿对低电量电池重新激活或重新充电（爆炸和腐蚀的危险）。

请勿拆解或损坏电池。请勿将电池投入明火中。

Table of Contents

	Page
1 Safety Instructions for Electric Drives and Controls.....	1
1.1 Definitions of Terms.....	1
1.2 Explanation of Signal Words and the Safety Alert Symbol.....	3
1.3 General Information.....	4
1.3.1 Using the Safety Instructions and Passing Them on to Others.....	4
1.3.2 Requirements for Safe Use.....	4
1.3.3 Hazards by Improper Use.....	6
1.4 Instructions with Regard to Specific Dangers.....	7
1.4.1 Protection Against Contact With Electrical Parts and Housings.....	7
1.4.2 Protective Extra-Low Voltage as Protection Against Electric Shock	8
1.4.3 Protection Against Dangerous Movements.....	8
1.4.4 Protection Against Magnetic and Electromagnetic Fields During Op- eration and Mounting.....	10
1.4.5 Protection Against Contact with Hot Parts.....	11
1.4.6 Protection During Handling and Mounting.....	11
2 Important Directions for Use.....	12
2.1 Appropriate Use.....	12
2.2 Inappropriate Use.....	12
3 Documentation Information.....	13
3.1 About this Documentation.....	13
3.2 Reference.....	13
4 Delivery and Storage.....	14
4.1 Product Identification.....	14
4.1.1 Packing Nameplate.....	14
4.1.2 Product Nameplate.....	15
4.2 Visual Inspection.....	15
4.3 Scope of Supply.....	15
4.4 Transport of the Components.....	16
4.5 Storage of the Components.....	16
5 Drive System Overview.....	17
6 Frequency Converter Overview.....	18
6.1 Product Features.....	18

	Page	
6.1.1	Input.....	18
6.1.2	Output.....	18
6.1.3	V/f Control Performance.....	18
6.1.4	SVC Control Performance.....	18
6.1.5	Main Functions.....	19
6.1.6	Communication.....	19
6.1.7	Operating Panel.....	20
6.1.8	Protection.....	20
6.1.9	Conditions.....	20
6.2	Technical Data.....	21
6.2.1	Electric Data.....	21
6.2.2	Derating of Electric Data.....	22
	Derating and ambient temperature.....	22
	Derating and mains voltage.....	23
	Derating and carrier frequency.....	24
7	Frequency Converter Mounting.....	25
7.1	Installation Conditions.....	25
7.2	Heat Dissipation.....	26
7.3	Air Flow of Fans.....	27
7.4	Figures and Dimensions.....	28
7.4.1	Figures.....	28
7.4.2	Dimensions.....	29
7.4.3	DIN Rail Mounting.....	30
8	Frequency Converter Wiring.....	31
8.1	Wiring Diagram.....	31
8.2	Cable Specifications.....	32
8.2.1	Power Cables.....	32
	Cable specification for international without USA / Canada.....	32
	Cable specification for USA / Canada.....	33
8.2.2	Control Cables.....	34
8.3	Terminals.....	34
8.3.1	Power Terminals.....	34
	Power Terminals Figure.....	34
	Power Terminals Description.....	35
	Notes on DC-bus terminals.....	36
8.3.2	Control Terminals.....	40
	Control terminals figure.....	40

	Page
Control terminals description.....	41
Digital input X1...X5 NPN / PNP wiring.....	43
Digital output DO1a, DO1b load pull-up / pull-down wiring.....	44
Analog input terminals (AI1, AI2, +10 V, +5 V, Earth and GND).....	44
Notes on DC_IN terminal.....	45
9 Electromagnetic Compatibility (EMC).....	46
9.1 EMC Requirements.....	46
9.1.1 General Information.....	46
The electromagnetic compatibility (EMC) or electromagnetic interference (EMI) includes the following requirements:.....	46
9.1.2 Noise Immunity in the Drive System.....	46
Basic structure for noise immunity.....	46
Minimum immunity requirements for PDSs intended for use in the second environment.....	47
Minimum immunity requirements for PDSs intended for use in the first environment.....	48
Evaluation criterion.....	49
9.1.3 Noise Emission of the Drive System.....	49
9.2 Ensuring the EMC Requirements.....	53
9.3 EMC Measures for Design and Installation.....	55
9.3.1 Rules for Design of Installations with Drive Controllers in Compliance with EMC.....	55
9.3.2 EMC-optimal Installation in Facility and Control Cabinet.....	57
9.3.3 Control Cabinet Mounting according to Interference Areas – Exemplary Arrangements.....	59
9.3.4 Design and Installation in Area A – Interference-free Area of Control Cabinet.....	60
9.3.5 Design and Installation in Area B – Interference-susceptible Area of Control Cabinet.....	62
9.3.6 Design and Installation in Area C – Strongly Interference-susceptible Area of Control Cabinet.....	63
9.3.7 Ground Connections.....	64
9.3.8 Installing Signal Lines and Signal Cables.....	65
9.3.9 General Measures of Radio Interference Suppression for Relays, Contactors, Switches, Chokes and Inductive Loads.....	66
10 Operating Panel and Dust Cover.....	67
10.1 LED Panel.....	67
10.2 LED Display.....	67

	Page
10.3	Dust Cover..... 68
10.4	LED Indicator..... 69
10.5	Operating Descriptions..... 70
10.6	Fast Access to Parameters with Button Combinations..... 71
10.7	Digit Shifting Function for Modification of Parameter Values..... 72
11	Quick Start..... 73
11.1	Checklist before Quick Start..... 73
11.1.1	Step 1: Check application conditions..... 73
11.1.2	Step 2: Check mounting conditions..... 73
11.1.3	Step 3: Check the wiring..... 73
11.2	Quick Start Parameters..... 74
11.3	Control the Motor..... 75
11.4	Motor Parameters Auto-Tuning..... 76
11.5	Possible Errors during Quick Start and Respective Solutions..... 77
11.6	Restoring Parameters to Factory Defaults..... 77
12	Functions and Parameters..... 78
12.1	Basic Settings..... 78
12.1.1	Parameter Group Access Control..... 78
12.1.2	Parameter Initialization..... 79
12.1.3	Parameter Replication..... 80
12.1.4	Password Protection..... 81
12.2	Input and Output Terminals Configuration..... 82
12.2.1	Digital Input Configuration..... 82
12.2.2	X5 Pulse Input Configuration..... 84
12.2.3	Analog Input Configuration..... 86
12.2.4	Digital Output Configuration..... 87
12.2.5	Analog Output Configuration..... 89
12.3	Power Stage Configuration..... 91
12.3.1	Set the Control Mode..... 91
12.3.2	Normal / Heavy Duty Setting..... 91
12.3.3	Carrier Frequency Setting..... 92
12.3.4	Fan Control..... 93
12.3.5	Fan Maintenance Reminder..... 94
12.4	Basic Frequency Setting Sources..... 95
12.4.1	Function Description..... 95
12.4.2	Select the Frequency Setting Source..... 96
	General setting..... 96

	Page
Frequency setting source switching.....	97
Frequency setting sources combination.....	98
Adjust the setting frequency by panel potentiometer.....	99
Adjust the setting frequency by panel button.....	99
Adjust the setting frequency by analog input AI1, AI2.....	100
Adjust the setting frequency by X5 pulse input.....	100
Adjust the setting frequency by digital input Up / Down command..	101
Adjust the setting frequency by multi-speed function.....	103
12.4.3 Acceleration and Deceleration Configuration.....	110
Acceleration and deceleration time configuration.....	110
Acceleration and deceleration curve mode configuration.....	111
12.4.4 Output Frequency Limitation.....	113
Direct output frequency limitation.....	113
Behavior at low speed running.....	113
12.4.5 Frequency Setting Saving.....	115
12.5 Run- / Stop- / Direction Command Source.....	116
12.5.1 Function Description.....	116
12.5.2 Run Command Source.....	117
First and second run command source configuration.....	117
Switch between first and second run command source.....	117
Stop command via panel <Stop> button.....	117
12.5.3 Direction Control.....	118
Direction control via operation panel.....	118
Direction change dead time.....	119
12.5.4 Start Behavior Setting.....	120
Start mode selection.....	120
Start directly.....	120
DC-braking before start.....	121
Start with speed capture.....	122
Automatic start / stop according to setting frequency.....	123
12.5.5 Stop Behavior Setting.....	125
Stop mode setting.....	125
DC-braking during deceleration to stop.....	126
Overexcitation braking.....	127
12.5.6 Resistor Braking.....	128
12.6 Special Running Behaviors.....	130
12.6.1 Skip Frequency.....	130
12.6.2 Jog Function.....	132

	Page
12.6.3 2-wire / 3-wire Control (Forward / stop, reverse / stop).....	134
2-wire control mode 1.....	134
2-wire control mode 2 (Forward / reverse, run / stop).....	135
3-wire control mode 1.....	136
3-wire control mode 2.....	137
Run / Stop.....	138
12.7 Special Functions.....	139
12.7.1 Counter Function.....	139
12.7.2 Frequency Arrival.....	141
12.7.3 Frequency Level Detection.....	142
12.7.4 High Resolution Current Display.....	143
12.8 Simple PLC.....	144
12.8.1 Function Description.....	144
12.8.2 Set the Simple PLC Mode.....	145
12.8.3 Set Speed / Direction / Acceleration and Deceleration Time.....	146
12.8.4 Stop and Pause Simple PLC Control.....	148
12.8.5 Indication of Simple PLC Status.....	149
12.9 PID Control.....	151
12.9.1 Function Description.....	151
12.9.2 Selecting the Reference and Feedback.....	152
12.9.3 Control Loop Configuration.....	153
12.9.4 PID Regulation Mode Setting.....	154
12.9.5 PID Deactivation by Digital Input.....	155
12.9.6 PID Engineering Value Display.....	155
12.9.7 PID Status Indication.....	156
12.9.8 Sleep / Wake Function.....	157
12.9.9 Pump Protection Function.....	159
12.10 Protection Functions.....	161
12.10.1 Converter Protection.....	161
Overload pre-warning.....	161
Stall overvoltage prevention.....	162
Stall overcurrent prevention.....	163
Phase loss protection.....	165
Analog Input Broken Wire Detection.....	165
12.10.2 Reaction to External Error Signals.....	166
12.10.3 Motor Protection.....	167
Motor derating frequency at low speed.....	167
Motor thermal protection without temperature sensor.....	168

	Page
Motor overload pre-warning.....	168
Motor thermal protection with temperature sensor.....	169
12.10.4 Resistor Braking Test.....	171
12.10.5 Power Fault Ride-through Setting.....	172
12.11 Motor Control.....	173
12.11.1 Motor Parameterization.....	173
Nameplate parameters configuration.....	173
Motor slip frequency configuration.....	174
Motor parameter auto-tuning.....	175
12.11.2 EFC 3610 - V/f Control.....	177
V/f curve selection.....	177
User-defined V/f curve configuration.....	178
Slip compensation factor configuration.....	180
Torque boost setting.....	181
Optimization functions for V/f control.....	184
12.11.3 EFC 5610 - SVC Control.....	186
SVC control loop configuration.....	186
Speed control mode.....	186
Torque control mode.....	187
13 Diagnosis.....	191
13.1 Display of LED Characters.....	191
13.2 Status Code.....	191
13.3 Warning Code.....	191
13.4 Error Code.....	192
13.4.1 Error 1 (OC-1): Overcurrent at Constant Speed.....	192
13.4.2 Error 2 (OC-2): Overcurrent during Acceleration.....	192
13.4.3 Error 3 (OC-3): Overcurrent during Deceleration.....	193
13.4.4 Error 4 (OE-1): Overvoltage at Constant Speed.....	193
13.4.5 Error 5 (OE-2): Overvoltage during Acceleration.....	193
13.4.6 Error 6 (OE-3): Overvoltage during Deceleration.....	194
13.4.7 Error 7 (OE-4): Overvoltage during Stop.....	194
13.4.8 Error 8 (UE-1): Undervoltage during Run.....	194
13.4.9 Error 9 (SC): Current Surge or Short Circuit.....	194
13.4.10 Error 10 (IPH.L): Input Phase Loss.....	195
13.4.11 Error 11 (OPH.L): Output Phase Loss.....	195
13.4.12 Error 12 (ESS-): Soft Start Error.....	195
13.4.13 Error 20 (OL-1): Converter Overload.....	196

	Page
13.4.14 Error 21 (OH): Converter over Temperature.....	196
13.4.15 Error 22 (UH): Converter under Temperature.....	196
13.4.16 Error 23 (FF): Fan Failure.....	196
13.4.17 Error 24 (Pdr): Pump Dry	197
13.4.18 Error 30 (OL2): Motor Overload.....	197
13.4.19 Error 31 (Ot): Motor over Temperature.....	197
13.4.20 Error 32 (t-Er): Motor Parameter Tuning Error.....	198
13.4.21 Error 38 (AibE): Analog Input Broken Wire Detection.....	198
13.4.22 Error 40 (dir1): Forward Running Lock Error.....	198
13.4.23 Error 41 (dir2): Reverse Running Lock Error.....	198
13.4.24 Error 42 (E-St): Terminal Error Signal.....	198
13.4.25 Error 43 (FFE-): Firmware Version Mismatch.....	199
13.4.26 Error 44 (rS-): Modbus Communication Error.....	199
13.4.27 Error 50 (idE-): Converter Internal Error.....	199
13.4.28 Error 55 (PbrE): Parameter Backup / Restore Error.....	199
13.5 Error Handling.....	200
13.5.1 Restarting after Power Loss.....	200
13.5.2 Automatic Error Reset.....	201
13.5.3 Error Reset by X1...X5 Digital Input.....	202
14 Communication.....	203
14.1 Brief Introduction.....	203
14.2 Basic Communication Settings.....	203
14.2.1 Selection of the Communication Protocol.....	203
14.2.2 Setting the Data Transmission Rate.....	203
14.2.3 Setting the Data Format.....	204
14.2.4 Setting the Local Address.....	204
14.2.5 Setting Command Signal Type.....	204
14.2.6 Communication Disruption and Response.....	205
14.3 Modbus Protocol.....	206
14.3.1 Protocol Description.....	206
Brief introduction.....	206
Transmission.....	207
14.3.2 Modbus Interface.....	208
14.3.3 Modbus Function and Message Format.....	208
Supported functions.....	208
Function example.....	210
Function 0x06: Write one register word.....	211

	Page
Function 0x08: Diagnostics.....	212
Function 0x10: Write N register words, range: 1...16.....	213
Function 0x17: Read/Write N register words, range: 1...16.....	213
Error code and exception code.....	215
14.3.4 Communication Mapping Register Address Distribution.....	216
Frequency converter parameter registers.....	216
Communication control registers.....	217
Communication state feedback registers (0x7FA0).....	218
14.3.5 Modbus Communication Example.....	219
14.3.6 Special Notes.....	220
14.3.7 Communication Networking.....	221
Networking.....	221
Recommendations on networking.....	221
15 Accessories.....	222
15.1 Optional Accessories.....	222
15.2 External EMC Filter.....	223
15.2.1 External EMC Filter Type.....	223
15.2.2 Technical Data.....	224
Dimensions.....	224
Electric data.....	228
15.3 External Brake Resistor.....	230
15.3.1 Braking Ratio.....	230
15.3.2 Brake Resistor Selection for Braking Ratio of 10 %.....	231
15.3.3 Brake Resistor Selection for Braking Ratio of 20 %.....	232
15.4 Shielded Cable Connector.....	233
15.5 Panel Mounting Plate.....	235
15.5.1 Function Description.....	235
15.5.2 Recommended Opening Dimensions at Control Cabinet.....	235
15.5.3 Mounting the Plate and the Operating Panel.....	236
Step 1.....	236
Step 2.....	236
Step 3.....	237
Step 4.....	237
15.6 Communication Cable for Control Cabinet.....	238
16 Maintenance.....	239
16.1 Safety Instructions.....	239
16.2 Daily Inspection.....	239

	Page
16.3	Periodic Inspection..... 240
16.4	Removable Components Maintenance..... 241
16.4.1	Construction Overview..... 241
16.4.2	Disassembly of the Operating Panel..... 242
16.4.3	Disassembly of Fans..... 243
17	Service and support..... 244
18	Environmental protection and disposal 245
18.1	Environmental protection..... 245
18.2	Disposal..... 245
19	Appendix..... 247
19.1	Appendix I: Abbreviations..... 247
19.2	Appendix II: Type Coding..... 248
19.2.1	Frequency Converter Type Coding..... 248
19.2.2	Operating Panel Type Coding..... 249
19.2.3	External EMC Filter Type Coding..... 250
19.2.4	Panel Mounting Plate Type Coding..... 251
19.2.5	Communication Cable for Control Cabinet Type Coding..... 251
19.2.6	Engineering Software Type Coding..... 252
19.3	Appendix III: Parameter List..... 253
19.3.1	Terminology and Abbreviation in Parameter List..... 253
19.3.2	Group b: System Parameters..... 253
	b0: Basic system parameters..... 253
19.3.3	Group C: Power Parameters..... 254
	C0: Power control parameters..... 254
	C1: Motor and system parameters..... 256
	C2: V/f control parameters..... 257
	C3: Vector control parameters..... 258
19.3.4	Group E: Function Control Parameters..... 259
	E0: Set point and control parameters..... 259
	E1: Input terminal parameters..... 262
	E2: Output terminal parameters..... 265
	E3: Multi-speed and simple PLC parameters..... 267
	E4: PID control parameters..... 269
	E5: Extended function parameters..... 270
	E8: Standard communication parameters..... 271
	E9: Protection and error parameters..... 271

	Page
19.3.5 Group U: Panel Parameters.....	273
U0: General panel parameters.....	273
U1: Seven-segment panel parameters.....	273
19.3.6 Group d0: Monitoring Parameters.....	274
19.4 Appendix IV: Certification.....	275
19.4.1 CE.....	275
19.4.2 UL.....	276

1 Safety Instructions for Electric Drives and Controls

1.1 Definitions of Terms

Documentation

A documentation comprises the entire documentation used to inform the user of the product about the use and safety-relevant features for configuring, integrating, mounting, installing, commissioning, operating, maintaining, repairing and decommissioning the product. The following terms are also used for this kind of documentation: Operating Instructions, Instruction Manual, Commissioning Manual, Application Description, Assembly Instructions, Project Planning Manual, Safety Notes, Product Insert, etc.

Component

A component is a combination of elements with a specified function, which are part of a piece of equipment, device or system. Components of the electric drive and control system are, for example, supply units, drive controllers, mains choke, mains filter, motors, cables, etc.

Control System

A control system comprises several interconnected control components placed on the market as a single functional unit.

Device

A device is a finished product with a defined function, intended for users and placed on the market as an individual piece of merchandise.

Electrical Equipment

Electrical equipment encompasses all devices used to generate, convert, transmit, distribute or apply electrical energy, such as electric motors, transformers, switching devices, cables, lines, power-consuming devices, circuit board assemblies, plug-in units, control cabinets, etc.

Electric Drive System

An electric drive system comprises all components from mains supply to motor shaft; this includes, for example, electric motor(s), motor encoder(s), supply units and drive controllers, as well as auxiliary and additional components, such as mains filter, mains choke and the corresponding lines and cables.

Installation

An installation consists of several devices or systems interconnected for a defined purpose and on a defined site which, however, are not intended to be placed on the market as a single functional unit.

Machine

A machine is the entirety of interconnected parts or units at least one of which is movable. Thus, a machine consists of the appropriate machine drive elements,

as well as control and power circuits, which have been assembled for a specific application. A machine is, for example, intended for processing, treatment, movement or packaging of a material. The term "machine" also covers a combination of machines which are arranged and controlled in such a way that they function as a unified whole.

Manufacturer

The manufacturer is an individual or legal entity bearing responsibility for the design and manufacture of a product which is placed on the market in the individual's or legal entity's name. The manufacturer can use finished products, finished parts or finished elements, or contract out work to subcontractors. However, the manufacturer must always have overall control and possess the required authority to take responsibility for the product.

Product

Examples of a product: Device, component, part, system, software, firmware, among other things.

Qualified Persons

In terms of this application documentation, qualified persons are those persons who are familiar with the installation, mounting, commissioning and operation of the components of the electric drive and control system, as well as with the hazards this implies, and who possess the qualifications their work requires. To comply with these qualifications, it is necessary, among other things,

- 1) to be trained, instructed or authorized to switch electric circuits and devices safely on and off, to ground them and to mark them
- 2) to be trained or instructed to maintain and use adequate safety equipment
- 3) to attend a course of instruction in first aid

User

A user is a person installing, commissioning or using a product which has been placed on the market.

1.2 Explanation of Signal Words and the Safety Alert Symbol

The Safety Instructions in the available application documentation contain specific signal words (DANGER, WARNING, CAUTION or NOTICE) and, where required, a safety alert symbol (in accordance with ANSI Z535.6-2011).

The signal word is meant to draw the reader's attention to the safety instruction and identifies the hazard severity.

The safety alert symbol (a triangle with an exclamation point), which precedes the signal words DANGER, WARNING and CAUTION, is used to alert the reader to personal injury hazards.

DANGER

In case of non-compliance with this safety instruction, death or serious injury **will** occur.

WARNING

In case of non-compliance with this safety instruction, death or serious injury **could** occur.

CAUTION

In case of non-compliance with this safety instruction, minor or moderate injury could occur.

NOTICE

In case of non-compliance with this safety instruction, property damage could occur.

1.3 General Information

1.3.1 Using the Safety Instructions and Passing Them on to Others

Do not attempt to install and operate the components of the electric drive and control system without first reading all documentation provided with the product. Read and understand these safety instructions and all user documentation prior to working with these components. If you do not have the user documentation for the components, contact your responsible Bosch Rexroth sales partner. Ask for these documents to be sent immediately to the person or persons responsible for the safe operation of the components.

If the component is resold, rented and/or passed on to others in any other form, these safety instructions must be delivered with the component in the official language of the user's country.

Improper use of these components, failure to follow the safety instructions in this document or tampering with the product, including disabling of safety devices, could result in property damage, injury, electric shock or even death.

1.3.2 Requirements for Safe Use

Read the following instructions before initial commissioning of the components of the electric drive and control system in order to eliminate the risk of injury and/or property damage. You must follow these safety instructions.

- Bosch Rexroth is not liable for damages resulting from failure to observe the safety instructions.
- Read the operating, maintenance and safety instructions in your language before commissioning. If you find that you cannot completely understand the application documentation in the available language, please ask your supplier to clarify.
- Proper and correct transport, storage, mounting and installation, as well as care in operation and maintenance, are prerequisites for optimal and safe operation of the component.
- Only qualified persons may work with components of the electric drive and control system or within its proximity.
- Only use accessories and spare parts approved by Bosch Rexroth.
- Follow the safety regulations and requirements of the country in which the components of the electric drive and control system are operated.
- Only use the components of the electric drive and control system in the manner that is defined as appropriate. See chapter "Appropriate Use".
- The ambient and operating conditions given in the available application documentation must be observed.
- Applications for functional safety are only allowed if clearly and explicitly specified in the application documentation "Integrated Safety Technology". If this is not the case, they are excluded. Functional safety is a safety concept in

which measures of risk reduction for personal safety depend on electrical, electronic or programmable control systems.

- The information given in the application documentation with regard to the use of the delivered components contains only examples of applications and suggestions.

The machine and installation manufacturers must

- make sure that the delivered components are suited for their individual application and check the information given in this application documentation with regard to the use of the components,
- make sure that their individual application complies with the applicable safety regulations and standards and carry out the required measures, modifications and complements.
- Commissioning of the delivered components is only allowed once it is sure that the machine or installation in which the components are installed complies with the national regulations, safety specifications and standards of the application.
- Operation is only allowed if the national EMC regulations for the application are met.
- The instructions for installation in accordance with EMC requirements can be found in the section on EMC in the respective application documentation.

The machine or installation manufacturer is responsible for compliance with the limit values as prescribed in the national regulations.

- The technical data, connection and installation conditions of the components are specified in the respective application documentations and must be followed at all times.

National regulations which the user must take into account

- European countries: In accordance with European EN standards
- United States of America (USA):
 - National Electrical Code (NEC)
 - National Electrical Manufacturers Association (NEMA), as well as local engineering regulations
 - Regulations of the National Fire Protection Association (NFPA)
- Canada: Canadian Standards Association (CSA)
- Other countries:
 - International Organization for Standardization (ISO)
 - International Electrotechnical Commission (IEC)

1.3.3 Hazards by Improper Use

- High electrical voltage and high working current! Danger to life or serious injury by electric shock!
- High electrical voltage by incorrect connection! Danger to life or injury by electric shock!
- Dangerous movements! Danger to life, serious injury or property damage by unintended motor movements!
- Health hazard for persons with heart pacemakers, metal implants and hearing aids in proximity to electric drive systems!
- Risk of burns by hot housing surfaces!
- Risk of injury by improper handling! Injury by crushing, shearing, cutting, hitting!
- Risk of injury by improper handling of batteries!
- Risk of injury by improper handling of pressurized lines!

1.4 Instructions with Regard to Specific Dangers

1.4.1 Protection Against Contact With Electrical Parts and Housings



This section concerns components of the electric drive and control system with voltages **higher than 50 volts**.

Contact with parts conducting voltages above 50 volts can cause personal danger and electric shock. When operating components of the electric drive and control system, it is unavoidable that some parts of these components conduct dangerous voltage.

High electrical voltage! Danger to life, risk of injury by electric shock or serious injury!

- Only qualified persons are allowed to operate, maintain and/or repair the components of the electric drive and control system.
- Follow the general installation and safety regulations when working on power installations.
- Before switching on, the equipment grounding conductor must have been permanently connected to all electric components in accordance with the connection diagram.
- Even for brief measurements or tests, operation is only allowed if the equipment grounding conductor has been permanently connected to the points of the components provided for this purpose.
- Before accessing electrical parts with voltage potentials higher than 50 V, you must disconnect electric components from the mains or from the power supply unit. Secure the electric component from reconnection.
- With electric components, observe the following aspects:

Always wait **5 minutes** after switching off power to allow live capacitors to discharge before accessing an electric component. Measure the electrical voltage of live parts before beginning to work to make sure that the equipment is safe to touch.

- Install the covers and guards provided for this purpose before switching on.
- Never touch electrical connection points of the components while power is turned on.
- Do not remove or plug in connectors when the component has been powered.
- Under specific conditions, electric drive systems can be operated at mains protected by residual-current-operated circuit-breakers sensitive to universal current (RCDs/RCMs).
- Secure built-in devices from penetrating foreign objects and water, as well as from direct contact, by providing an external housing, for example a control cabinet.

High housing voltage and high leakage current! Danger to life, risk of injury by electric shock!

- Before switching on and before commissioning, ground or connect the components of the electric drive and control system to the equipment grounding conductor at the grounding points.
- Connect the equipment grounding conductor of the components of the electric drive and control system permanently to the main power supply at all times. The leakage current is greater than 3.5 mA.

1.4.2 Protective Extra-Low Voltage as Protection Against Electric Shock

Protective extra-low voltage is used to allow connecting devices with basic insulation to extra-low voltage circuits.

On components of an electric drive and control system provided by Bosch Rexroth, all connections and terminals with voltages between 5 and 50 volts are PELV ("Protective Extra-Low Voltage") systems. It is allowed to connect devices equipped with basic insulation (such as programming devices, PCs, notebooks, display units) to these connections.

Danger to life, risk of injury by electric shock! High electrical voltage by incorrect connection!

If extra-low voltage circuits of devices containing voltages and circuits higher than 50 volts (e.g., the mains connection) are connected to Bosch Rexroth products, the connected extra-low voltage circuits must comply with the requirements for PELV ("Protective Extra-Low Voltage").

1.4.3 Protection Against Dangerous Movements

Dangerous movements can be caused by faulty control of connected motors. Some common examples are:

- Improper or wrong wiring or cable connection
- Operator errors
- Wrong input of parameters before commissioning
- Malfunction of sensors and encoders
- Defective components
- Software or firmware errors

These errors can occur immediately after equipment is switched on or even after an unspecified time of trouble-free operation.

The monitoring functions in the components of the electric drive and control system will normally be sufficient to avoid malfunction in the connected drives. Regarding personal safety, especially the danger of injury and/or property damage, this alone cannot be relied upon to ensure complete safety. Until the integrated monitoring functions become effective, it must be assumed in any case

that faulty drive movements will occur. The extent of faulty drive movements depends upon the type of control and the state of operation.

Dangerous movements! Danger to life, risk of injury, serious injury or property damage!

A **risk assessment** must be prepared for the installation or machine, with its specific conditions, in which the components of the electric drive and control system are installed.

As a result of the risk assessment, the user must provide for monitoring functions and higher-level measures on the installation side for personal safety. The safety regulations applicable to the installation or machine must be taken into consideration. Unintended machine movements or other malfunctions are possible if safety devices are disabled, bypassed or not activated.

To avoid accidents, injury and/or property damage:

- Keep free and clear of the machine's range of motion and moving machine parts. Prevent personnel from accidentally entering the machine's range of motion by using, for example:
 - Safety fences
 - Safety guards
 - Protective coverings
 - Light barriers
- Make sure the safety fences and protective coverings are strong enough to resist maximum possible kinetic energy.
- Mount emergency stopping switches in the immediate reach of the operator. Before commissioning, verify that the emergency stopping equipment works. Do not operate the machine if the emergency stopping switch is not working.
- Prevent unintended start-up. Isolate the drive power connection by means of OFF switches/OFF buttons or use a safe starting lockout.
- Make sure that the drives are brought to safe standstill before accessing or entering the danger zone.
- Disconnect electrical power to the components of the electric drive and control system using the master switch and secure them from reconnection ("lock out") for:
 - Maintenance and repair work
 - Cleaning of equipment
 - Long periods of discontinued equipment use
- Prevent the operation of high-frequency, remote control and radio equipment near components of the electric drive and control system and their supply leads. If the use of these devices cannot be avoided, check the machine or installation, at initial commissioning of the electric drive and control system, for possible malfunctions when operating such high-frequency, remote control

and radio equipment in its possible positions of normal use. It might possibly be necessary to perform a special electromagnetic compatibility (EMC) test.

1.4.4 Protection Against Magnetic and Electromagnetic Fields During Operation and Mounting

Magnetic and electromagnetic fields generated by current-carrying conductors or permanent magnets of electric motors represent a serious danger to persons with heart pacemakers, metal implants and hearing aids.

Health hazard for persons with heart pacemakers, metal implants and hearing aids in proximity to electric components!

- Persons with heart pacemakers and metal implants are not allowed to enter the following areas:
 - Areas in which components of the electric drive and control systems are mounted, commissioned and operated.
 - Areas in which parts of motors with permanent magnets are stored, repaired or mounted.
- If it is necessary for somebody with a heart pacemaker to enter such an area, a doctor must be consulted prior to doing so. The noise immunity of implanted heart pacemakers differs so greatly that no general rules can be given.
- Those with metal implants or metal pieces, as well as with hearing aids, must consult a doctor before they enter the areas described above.

1.4.5 Protection Against Contact with Hot Parts

Hot surfaces of components of the electric drive and control system. Risk of burns!

- Do not touch hot surfaces of, for example, braking resistors, heat sinks, supply units and drive controllers, motors, windings and laminated cores!
- According to the operating conditions, temperatures of the surfaces can be **higher than 60 °C** (140 °F) during or after operation.
- Before touching motors after having switched them off, let them cool down for a sufficient period of time. Cooling down can require **up to 140 minutes!** The time required for cooling down is approximately five times the thermal time constant specified in the technical data.
- After switching chokes, supply units and drive controllers off, wait **15 minutes** to allow them to cool down before touching them.
- Wear safety gloves or do not work at hot surfaces.
- For certain applications, and in accordance with the respective safety regulations, the manufacturer of the machine or installation must take measures to avoid injuries caused by burns in the final application. These measures can be, for example: Warnings at the machine or installation, guards (shieldings or barriers) or safety instructions in the application documentation.

1.4.6 Protection During Handling and Mounting

Risk of injury by improper handling! Injury by crushing, shearing, cutting, hitting!

- Observe the relevant statutory regulations of accident prevention.
- Use suitable equipment for mounting and transport.
- Avoid jamming and crushing by appropriate measures.
- Always use suitable tools. Use special tools if specified.
- Use lifting equipment and tools in the correct manner.
- Use suitable protective equipment (hard hat, safety goggles, safety shoes, safety gloves, for example).
- Do not stand under hanging loads.
- Immediately clean up any spilled liquids from the floor due to the risk of falling!

2 Important Directions for Use

2.1 Appropriate Use

Bosch Rexroth products represent state-of-the-art developments and manufacturing. They are tested prior to delivery to ensure operating safety and reliability.

The products can only be used in the appropriate way. Otherwise, situations resulting in property damage and personal injury may occur.



Bosch Rexroth as manufacturer is not liable for any damages resulting from inappropriate use. In such cases, the guarantee and the right to payment of damages resulting from inappropriate use are forfeited. The user alone carries all responsibility of the risks.

Before using Bosch Rexroth products, make sure that all the pre-requisites for appropriate use of the products are satisfied.

- Personnel that in any way or form use our products must first read and understand the relevant safety instructions and be familiar with appropriate use.
- If the products take the form of hardware, they must remain in their original state, in other words, no structural changes are permitted.
- It is not permitted to decompile software products or alter source codes.
- Do not mount damaged or faulty products or use them in operation.
- Make sure that the products have been installed in the manner described in the relevant documentation.

2.2 Inappropriate Use

Using the frequency converters outside of the operating conditions described in this manual and outside of the indicated technical data and specifications is defined as "**inappropriate use**".

Frequency converters shall not be used under following conditions:

- They are subject to operating conditions that do not meet the specified ambient conditions. These include, for example, operation under water, extreme temperature fluctuations or extremely high temperatures.
- Furthermore, the frequency converters shall not be used in applications which have not been expressly authorized by Rexroth. Please carefully follow the specifications outlined in the general Safety Instructions!

3 Documentation Information

3.1 About this Documentation

This **Operating Instructions** contains necessary data and information related to the product, which is the basis for any of other types of documentation.

WARNING

Personal injury or property damage caused by incorrect operations of applications, machines and installations!

Do not attempt to install or put the product into operation until you have completely read and understood the descriptions in this documentation!

3.2 Reference

For documentation available in other type or language, please consult your local **Bosch Rexroth** sales partner or check www.boschrexroth.com/efcx610.

Documentation type	Short text / Type code	Language	Material number
Operating Instructions	DOK-RCON03-EFC-x610***-ITRS-ZH-P	Chinese	R912005853
	DOK-RCON03-EFC-x610***-ITRS-EN-P	English	R912005854
Quick Start Guide	DOK-RCON03-EFC-x610***-QRS-ZH-P	Chinese	R912005855
	DOK-RCON03-EFC-x610***-QRS-EN-P	English	R912005856
Safety Instructions	DOK-RCON**-SAFETY*****-SARS-BP-P	Portuguese	R911339218
	DOK-RCON**-SAFETY*****-SARS-DE-P	German	R911339363
	DOK-RCON**-SAFETY*****-SARS-EN-P	English	R911339362
	DOK-RCON**-SAFETY*****-SARS-ES-P	Spanish	R911339216
	DOK-RCON**-SAFETY*****-SARS-FR-P	French	R911339213
	DOK-RCON**-SAFETY*****-SARS-IT-P	Italian	R911339215
	DOK-RCON**-SAFETY*****-SARS-RU-P	Russian	R911339217
	DOK-RCON**-SAFETY*****-SARS-ZH-P	Chinese	R912004727
Instruction Manual (UL)	DOK-RCON01-REXF*UL***-INRS-EN-P	English	R912004711

Tab. 3-1: Documentation overview

4 Delivery and Storage

4.1 Product Identification

4.1.1 Packing Nameplate

Check if the model information on the packing nameplate is the same as you ordered **immediately** after receipt. If the model is wrong, please contact Bosch Rexroth distributor.

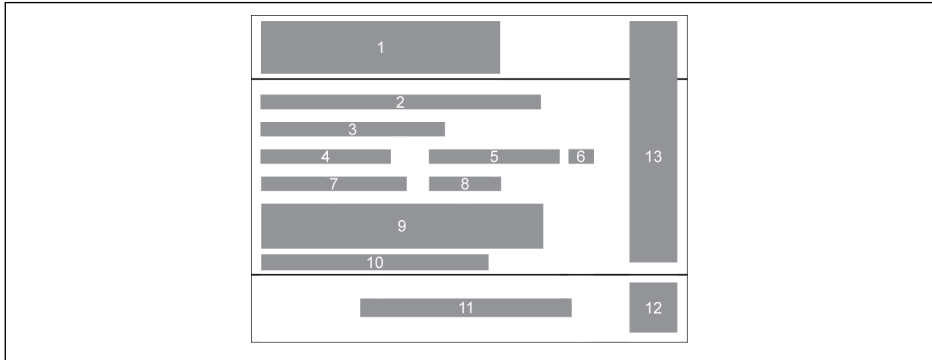

- | | | | |
|----------|------------------------|-----------|--|
| 1 | Product series | 8 | Production week: e.g., 14W20 means week 20 in 2014 |
| 2 | Short text / Type code | 9 | Bar code |
| 3 | Volume | 10 | Serial number |
| 4 | Net weight | 11 | Manufacturer |
| 5 | Material number | 12 | 2D code |
| 6 | Product version index | 13 | Certification |
| 7 | Mass weight | | |

Fig. 4-1: Packing nameplate

4.1.2 Product Nameplate

Check if the model information on product nameplate is the same as you ordered **immediately** after unpacking. If the model is wrong, please contact Bosch Rexroth distributor.

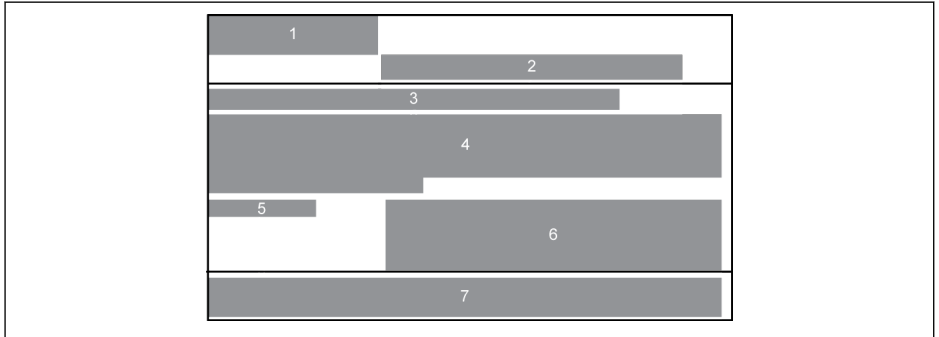

- | | |
|---|---|
| <p>1 Brand logo
 2 Product series
 3 Short text / Type code
 4 Technical data</p> | <p>5 Production week: e.g., 14W20 means week 20 in 2014
 6 Certification
 7 Manufacturer</p> |
|---|---|

Fig. 4-2: Product nameplate

4.2 Visual Inspection

Check the product for transport damages, e.g. deformation or loose parts, immediately after unpacking. In case of damage, contact the forwarder at once and arrange for a thorough review of the situation.



This is also applicable if the packaging is undamaged.

4.3 Scope of Supply

If any of the following standard supply items is missing, please contact Bosch Rexroth distributor.

- Frequency Converter EFC x610 (According to type code)
- Safety Instructions (Multi-lingual)
- Quick Start Guide
- Instruction Manual (UL)

4.4 Transport of the Components

Description	Symbol	Unit	Value
Temperature range	T_{a_tran}	°C	-25...70
Relative humidity	-	%	5...95
Absolute humidity	-	g/m^3	1...60
Climate category (IEC 721)	-	-	2K3
Moisture condensation	-	-	not allowed
Icing	-	-	not allowed

Tab. 4-1: Transport conditions

4.5 Storage of the Components

CAUTION

Damage to the components caused by long storage periods!

A frequency converter contains electrolytic capacitors which may deteriorate during storage.

When storing these components for a long period of time, remember to operate them once a year:

- Run Frequency Converter EFC x610 under power U_{LN} for at least 1 hour.
- For more information of electrolytic capacitors, please contact service.

Description	Symbol	Unit	Value
Temperature range	T_{a_store}	°C	-20...60
Relative humidity	-	%	5...95
Absolute humidity	-	g/m^3	1...29
Climate category (IEC 721)	-	-	1K3
Moisture condensation	-	-	not allowed
Icing	-	-	not allowed

Tab. 4-2: Storage conditions

5 Drive System Overview

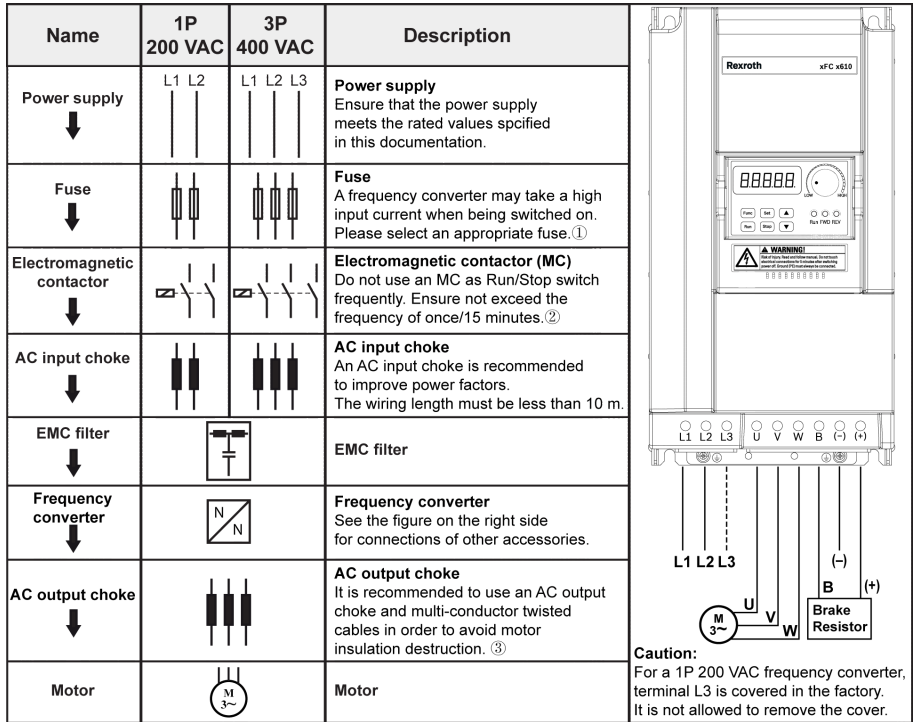

Fig. 5-1: Drive system overview



- ①: To select an appropriate fuse, see [chapter 8.2.1 "Power Cables" on page 32](#).
- ②: Excessively frequent starting and stopping will shorten the life time of relay contacts and DC-bus capacitors, and may destroy the resistor for capacitor charging and current limitation.
- ③: Whether using an AC output choke or not depends on the factors of: the length, shielding and distribution capacitance of the motor cables, as well as the insulation of the motor.

6 Frequency Converter Overview

6.1 Product Features

6.1.1 Input

Power supply voltage	1P 200...240 VAC (-10 % / +10 %) (IT-Net, TN-Net) 3P 380...480 VAC (-15 % / +10 %) (IT-Net, TN-Net)
Power supply frequency	50 / 60 Hz (± 5 %)

6.1.2 Output

Rated voltage	Corresponding to input voltage
Rated power	0.4...2.2 kW (1P 200 VAC) 0.4...18.5 kW (3P 400 VAC)
Rated frequency	0.00...400.00 Hz
Default carrier frequency	ND: 4 kHz; HD: 6 kHz
Carrier frequency range	1...15 kHz
Efficiency	> 95 %
Overload capability	HD: 150 % of rated current for 60 s ND: 120 % of rated current for 60 s

6.1.3 V/f Control Performance

V/f curve	Linear mode, square curve mode, user-defined multi-point curve mode
Speed regulation range	1:50
Start-up torque	150 % of rated torque at 3.00 Hz 100 % of rated torque at 1.50 Hz

6.1.4 SVC Control Performance

Speed regulation range	1:200
Start-up torque	200 % of rated torque at 0.50 Hz

6.1.5 Main Functions

Frequency setting resolution	Analog setting: 1/1,000 of maximum frequency Digital setting: 0.01 Hz
Frequency setting accuracy	Analog setting: ± 0.1 % of maximum frequency (25 °C \pm 10 °C) Digital setting: ± 0.01 % of maximum frequency (-10...50 °C)
Acceleration / deceleration curve mode	Linear, S-curve 8 sets of acceleration / deceleration time: 0.1...6,000.0 s
Stop DC-braking	DC-braking initial frequency: 0.00...50.00 Hz DC-braking time: 0.0...20.0 s Stop DC-braking current: 0.0...150.0 %
Jog function	Jog frequency range: 0.00 Hz...maximum output frequency Jog acceleration / deceleration time: 0.1...6,000.0 s
Multi-speed control	16 stages by digital input control
Simple PLC control	16 stages with pause / stop control
PID control	PID control with sleep / wake function
Digital input	5 digital inputs support PNP and NPN wiring, X5 supports 50.0 kHz pulse input
Analog input	2 Analog inputs: 0 / 2...10 V or 0 / 4...20 mA
Digital output	1 Open collector output, supports 32.0 kHz pulse output and pull-up and pull-down wiring 1 Relay output
Analog output	Analog output 0 / 2...10 V or 0 / 4...20 mA, to output setting frequency, output frequency, output current, output power, output voltage, analog input voltage and analog input current
Other functions	Carrier frequency automatic adjustment, first and second frequency setting source, slip compensation, torque boost, automatic voltage stabilization, power loss restart, 2-wire / 3-wire control, quick start parameters, parameter replication, output current limitation, power fault ride-through, etc.

6.1.6 Communication

Communication protocol	Modbus
Communication interface	RS485

6.1.7 Operating Panel

LED panel	Display: Display parameters, settings, status codes, warning codes and error codes
	Buttons: Set parameters, switch display, reset warnings, execute run and stop command, increase or decrease parameter group / code / value
	Potentiometer: Set frequency
	Indicator: Run, FWD, REV
Dust cover	Indicating Run, FWD, REV and Power

6.1.8 Protection

Over current protection, over- / under- voltage protection, current surge / short circuit protection, input / output phase loss protection, converter over- / under- temperature protection, motor overload protection, motor over temperature protection, direction lock protection, analog input broken wire detection, etc.

6.1.9 Conditions

Rated ambient temperature	-10...45 °C
Derating / ambient temperature	1.5 % / 1 °C (45...55 °C)
Rated storage temperature	-20...60 °C
Rated altitude	≤ 1,000 m
Derating / altitude	1 % / 100 m (1,000...4,000 m)
Relative humidity	≤ 90 % RH (No condensation)
Degrees of protection	IP 20 (Open type)
Degrees of pollution	2 (EN 50178)
Shocking	< 5.9 m/s ² (0.6 G)
Mounting mode	Wall mounting, DIN rail mounting
Cooling type	Natural cooling (≤ 0K75)
	Enforced air cooling (≥ 1K50)
Certification	CE
	cUL

6.2 Technical Data

6.2.1 Electric Data

Model	Output power		Input current		200 V / 240 V		Output capacity	
	[kW]		[A]		Output current [A]		[kVA]	
0K40	0.4		6.2		2.4 / 2.0		0.8	
0K75	0.75		10.1		4.1 / 3.4		1.4	
1K50	1.5		16.2		7.3 / 6.1		2.5	
2K20	2.2		22.3		10.1 / 8.4		3.5	

Tab. 6-1: 1P 200 VAC 0K40...2K20 electric data

Model	Output power		Input current		380 V / 480 V		Output capacity	
	[kW]		[A]		Output current [A]		[kVA]	
0K40	0.4		1.5		1.3 / 1.1		0.9	
0K75	0.75		2.6		2.3 / 1.8		1.5	
1K50	1.5		4.8		4.0 / 3.2		2.7	
2K20	2.2		6.8		5.6 / 4.4		3.7	
3K00	3.0		9.1		7.4 / 5.9		4.9	
4K00	4.0		11.9		9.7 / 7.7		6.4	

Tab. 6-2: 3P 400 VAC 0K40...4K00 electric data



Model 3K00: **ONLY available** with EFC 3610.

Model	Output power		Input current		380 V / 480 V		Output capacity	
	[kW]		[A]		Output current [A]		[kVA]	
	HD	ND	HD	ND	HD	ND	HD	ND
5K50	5.5	7.5	15.7	21.0	12.7/10.0	16.8/13.3	8.3	11.1
7K50	7.5	11.0	21.0	28.0	16.8/13.3	24.3/19.2	11.1	16.0
11K0	11.0	15.0	28.0	37.8	24.3/19.2	32.4/25.6	16.0	21.3
15K0	15.0	18.5	37.8	45.8	32.4/25.6	39.2/31.0	21.3	25.8
18K5	18.5	22.0	45.8	52.7	39.2/31.0	45.0/36.0	25.8	29.7

Tab. 6-3: 3P 400 VAC 5K50...18K5 electric data



ND: Normal Duty, **ONLY available** with EFC 3610.

HD: Heavy Duty, available with both EFC 3610 and EFC 5610.

6.2.2 Derating of Electric Data

Derating and ambient temperature

The ambient temperature for Frequency Converter EFC x610 is -10...55 °C. Out of this range, there will be no possibility to install and run the frequency converter, even the performance data have been additionally reduced.

- If the ambient temperature is -10...45 °C, there will be no need for derating.
- If the ambient temperature is 45...55 °C, derating must be performed as indicated in the figure below.

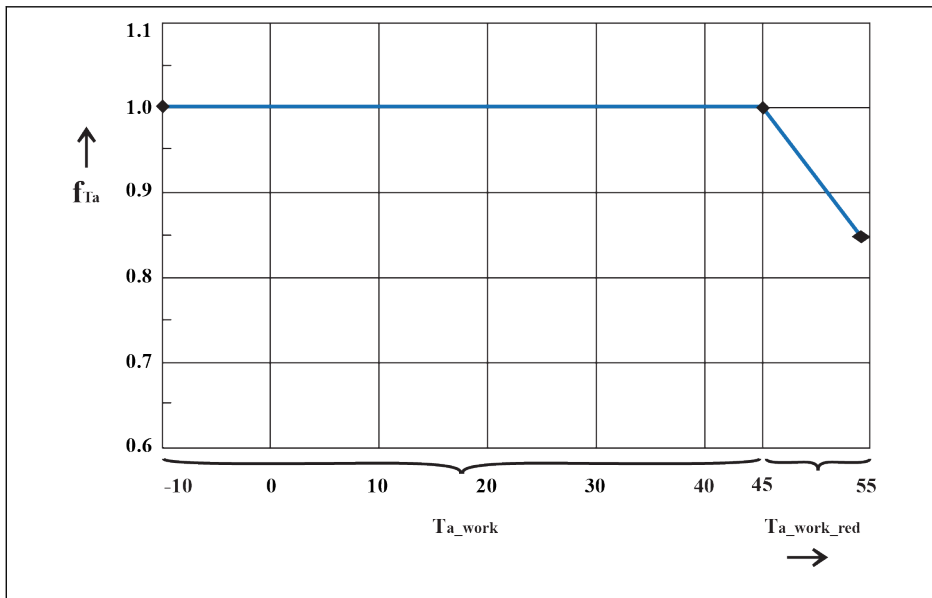

f_{Ta}
 T_{a_work}

Load factor
Ambient temperature range for
operation with rated data

$T_{a_work_red}$ Ambient temperature range for
operation with reduced rated
data

Fig. 6-1: Derating and ambient temperature (°C)

Derating and mains voltage

Reduce overcurrent based on mains voltage.

Frequency Converter EFC x610 is thermally dimensioned for the rated current. This rated current is available with the specified rated voltage. With deviating voltages in the permissible range, please pay attention to the following:

- $U_{\text{mains}} < U_{\text{rated}}$:

With mains voltage below the rated voltage, no higher current may be withdrawn to ensure that the dissipated power remains.

- $U_{\text{mains}} > U_{\text{rated}}$:

With mains voltage above the rated voltage, a reduction of the permissible output permanent current takes place to compensate for the increased switching losses.

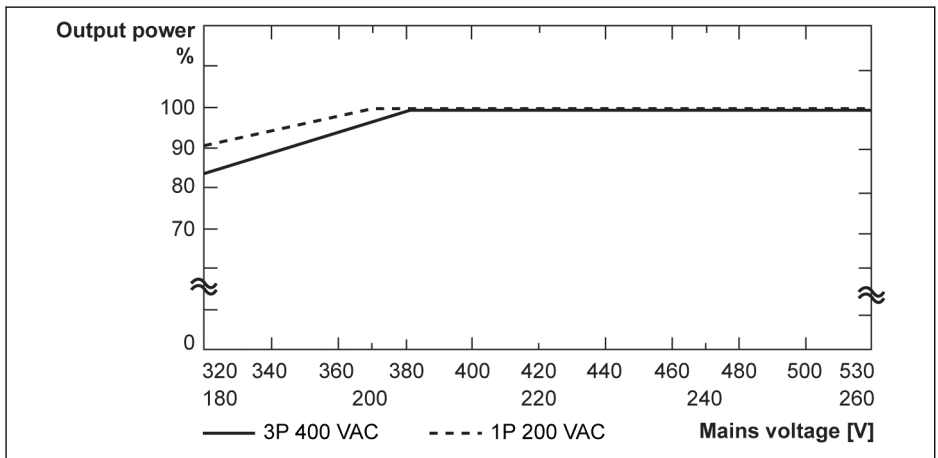

Fig. 6-2: Derating and mains voltage



- 3P 400 VAC: 1 % power derating every 4 V lower than 380 V.
- 1P 200 VAC: 1 % power derating every 2 V lower than 200 V.

Derating and carrier frequency

In case of higher carrier frequency, the output current is reduced so that the power dissipation in power section remains more or less constant. The figure below shows the current reduction based on the carrier frequency for the frequency converters:

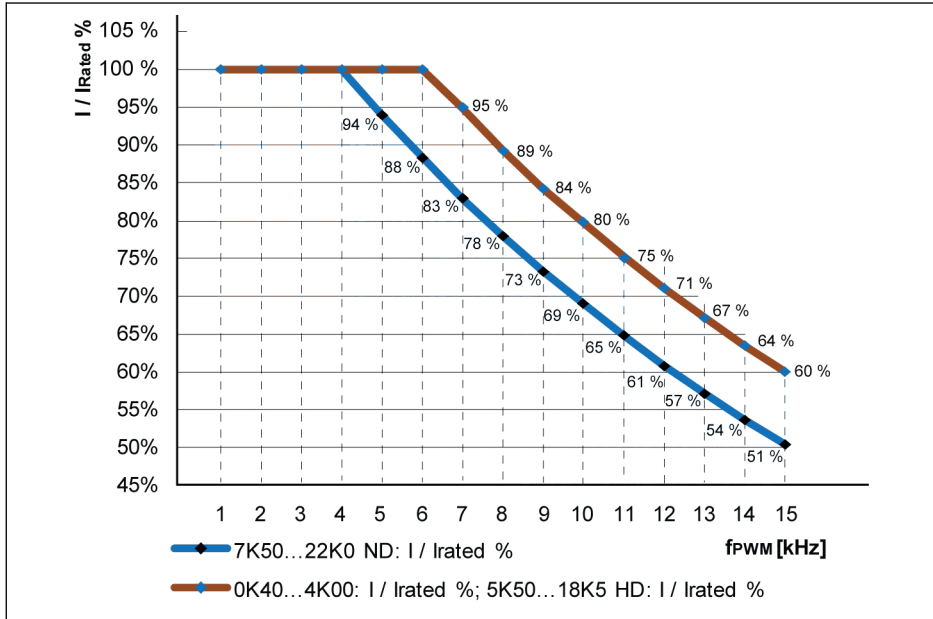

I / I_{rated} % Percentage of rated output current
 f_{PWM} PWM or carrier frequency

Fig. 6-3: Derating and carrier frequency

7 Frequency Converter Mounting

7.1 Installation Conditions

The frequency converter must be vertically installed.

If one frequency converter is arranged above another, make sure the upper limit of air temperature into the inlet is not exceeded (see [chapter 6.1.9 "Conditions on page 20"](#)). An air guide is recommended between the frequency converters to prevent the rising hot air being drawn into the upper frequency converter if the upper limit of air temperature is exceeded.

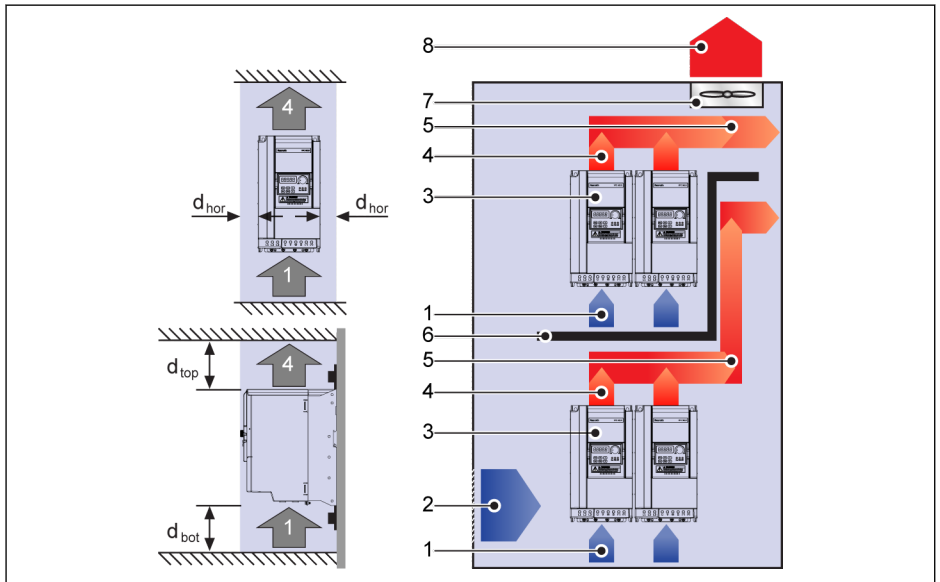

Fig. 7-1: Mounting distance and arrangement

d_{hor} : Distance horizontal = 0 mm (allows side-by-side mounting)

d_{top} : Distance top = 125 mm

d_{bot} : Distance bottom = 125 mm

- 1: Air inlet at frequency converter
- 2: Air inlet at control cabinet
- 3: Frequency converter
- 4: Air outlet at frequency converter
- 5: Heated air conveying direction
- 6: Air guide in control cabinet
- 7: Fan in control cabinet
- 8: Discharge of heated air

7.2 Heat Dissipation

1P 200 VAC

Frame	Model	Rated output current [A]	Heat dissipation	
			[W]	[BTU/h]
B	0K40	2.4	40	136
B	0K75	4.1	70	256
C	1K50	7.3	120	409
D	2K20	10.1	165	563

Tab. 7-1: 1P 200 VAC heat dissipation

3P 400 VAC

Frame	Model	Rated output current [A]	Heat dissipation	
			[W]	[BTU/h]
B	0K40	1.3	20	68
B	0K75	2.3	37	126
C	1K50	4.0	75	256
C	2K20	5.6	99	338
D	3K00	7.4	135	461
D	4K00	9.7	180	614
E	5K50	12.7	247	843
E	7K50	16.8	338	1,153
F	11K0	24.3	462	1,576
F	15K0	32.4	570	1,945
G	18K5	39.2	703	2,399

Tab. 7-2: 3P 400 VAC heat dissipation



Model 3K00: **ONLY** available with EFC 3610.

7.3 Air Flow of Fans

1P 200 VAC

Frame	Model	Fan for heat sink		Fan for internal components	
		[CFM]	[m ³ /min]	[CFM]	[m ³ /min]
B	0K40	–	–	–	–
B	0K75	–	–	–	–
C	1K50	19.20	0.54	21.70	0.61
D	2K20	19.20	0.54	21.70	0.61

Tab. 7-3: 1P 200 VAC air flow of fans

3P 400 VAC

Frame	Model	Fan for heat sink		Fan for internal components	
		[CFM]	[m ³ /min]	[CFM]	[m ³ /min]
B	0K40	–	–	–	–
B	0K75	–	–	–	–
C	1K50	19.20	0.54	21.70	0.61
C	2K20	19.20	0.54	21.70	0.61
D	3K00	19.20	0.54	21.70	0.61
D	4K00	19.20	0.54	21.70	0.61
E	5K50	40.00	1.13	32.17	0.91
E	7K50	40.00	1.13	32.17	0.91
F	11K0	56.50	1.60	34.90	0.99
F	15K0	56.50	1.60	34.90	0.99
G	18K5	40.00	1.13	34.90	0.99

Tab. 7-4: 3P 400 VAC air flow of fans



- Model 3K00: **ONLY available** with EFC 3610.
- Quantity of fans
 - Each model has only one fan for internal components.
 - Each model of 0K40...15K0 has only one fan for heat sink.
 - Model 18K5 has **TWO** fans for heat sink.

7.4 Figures and Dimensions

7.4.1 Figures

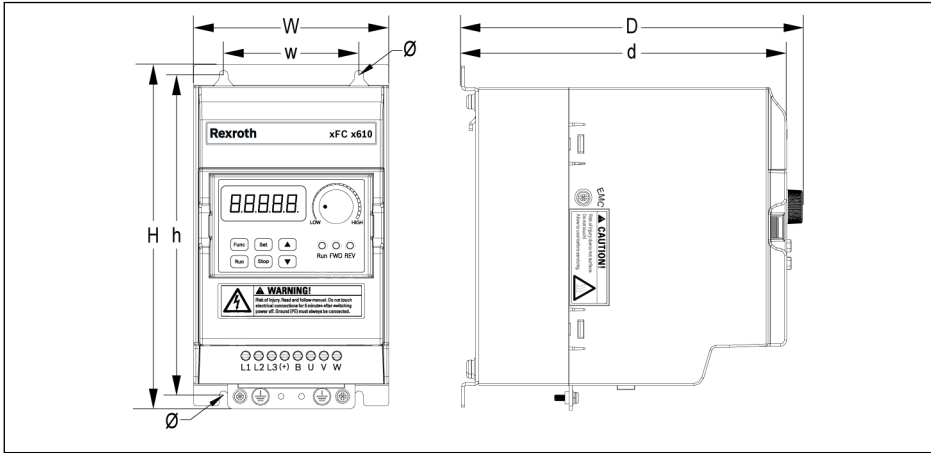

Fig. 7-2: EFC x610 0K40...4K00 dimensions figure

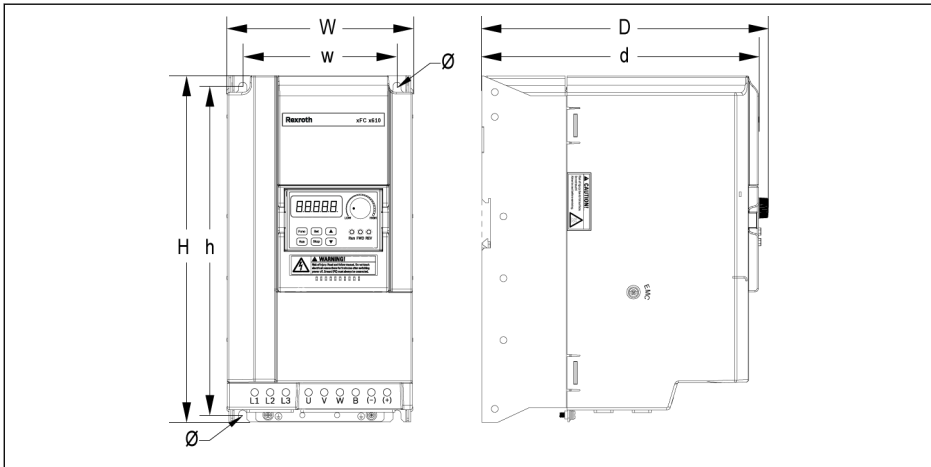

Fig. 7-3: EFC x610 5K50...18K5 dimensions figure

7.4.2 Dimensions

Frame	Model ^①	Dimensions [mm]							Screw size ^②	Net weight [kg]
		W	H	D	w	h	d	∅		
B	0K40	95	166	167	66	156	159	4.5	M4	1.5
B	0K75	95	166	167	66	156	159	4.5	M4	1.5
C	1K50	95	206	170	66	196	162	4.5	M4	1.9
D	2K20	120	231	175	80	221	167	4.5	M4	2.6

Tab. 7-5: EFC x610 1P 200 VAC dimensions

Frame	model ^①	Dimensions [mm]							Screw size ^②	Net weight [kg]
		W	H	D	w	h	d	∅		
B	0K40	95	166	167	66	156	159	4.5	M4	1.5
B	0K75	95	166	167	66	156	159	4.5	M4	1.5
C	1K50	95	206	170	66	196	162	4.5	M4	1.9
C	2K20	95	206	170	66	196	162	4.5	M4	1.9
D	3K00	120	231	175	80	221	167	4.5	M4	2.6
D	4K00	120	231	175	80	221	167	4.5	M4	2.6
E	5K50	130	243	233	106	228	225	6.5	M6	3.9
E	7K50	130	243	233	106	228	225	6.5	M6	4.3
F	11K0	150	283	233	125	265	225	6.5	M6	5.7
F	15K0	150	283	233	125	265	225	6.5	M6	6.4
G	18K5	165	313	241	140	295	233	6.5	M6	8.0

Tab. 7-6: EFC x610 3P 400 VAC dimensions



- ^①: The complete type code for frequency converter is: EFCx610-xKxx-xPx-MDA-xx-NNNNN-NNNN, see [chapter 19.2 "Appendix II: Type Coding" on page 248](#).
E.g., type code for EFC 5610 5K50 (3P 400 VAC model) is: EFC5610-5K50-3P4-MDA-7P-NNNNN-NNNN.
- Model 3K00: ONLY available with EFC 3610.
- ^②: 4 screws are needed for wall mounting of EFC x610.

7.4.3 DIN Rail Mounting

Besides wall mounting with screws, Frequency Converter EFC x610 also provides DIN rail mounting for models 0K40...7K50.

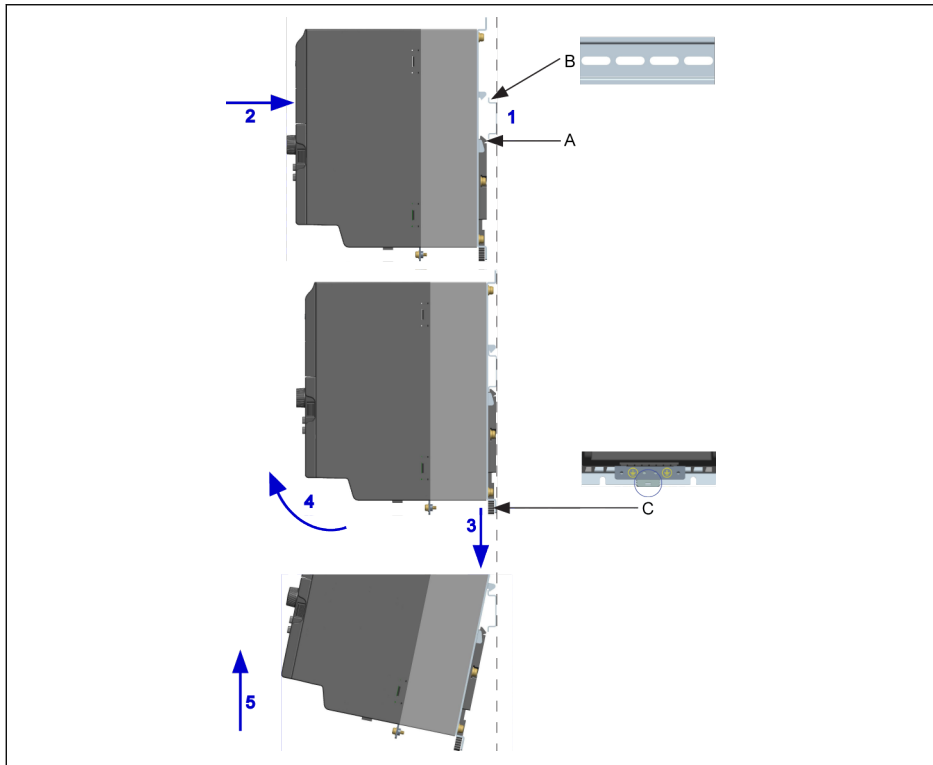

A Mounting buckle
B Mounting rail

C Disassembly handle

Fig. 7-4: DIN rail mounting and disassembly

Mounting steps:

- 1: Hold the frequency converter and keep component A and the lower edge of component B at the same position level.
- 2: Push the frequency converter horizontally till a buckle sound indicates a successful mounting.

Disassembly steps:

- 3: Pull down component C and hold it.
- 4: Rotate the frequency converter to an appropriate angle as the arrow indicates.
- 5: Lift the frequency converter upwards.

8 Frequency Converter Wiring

8.1 Wiring Diagram

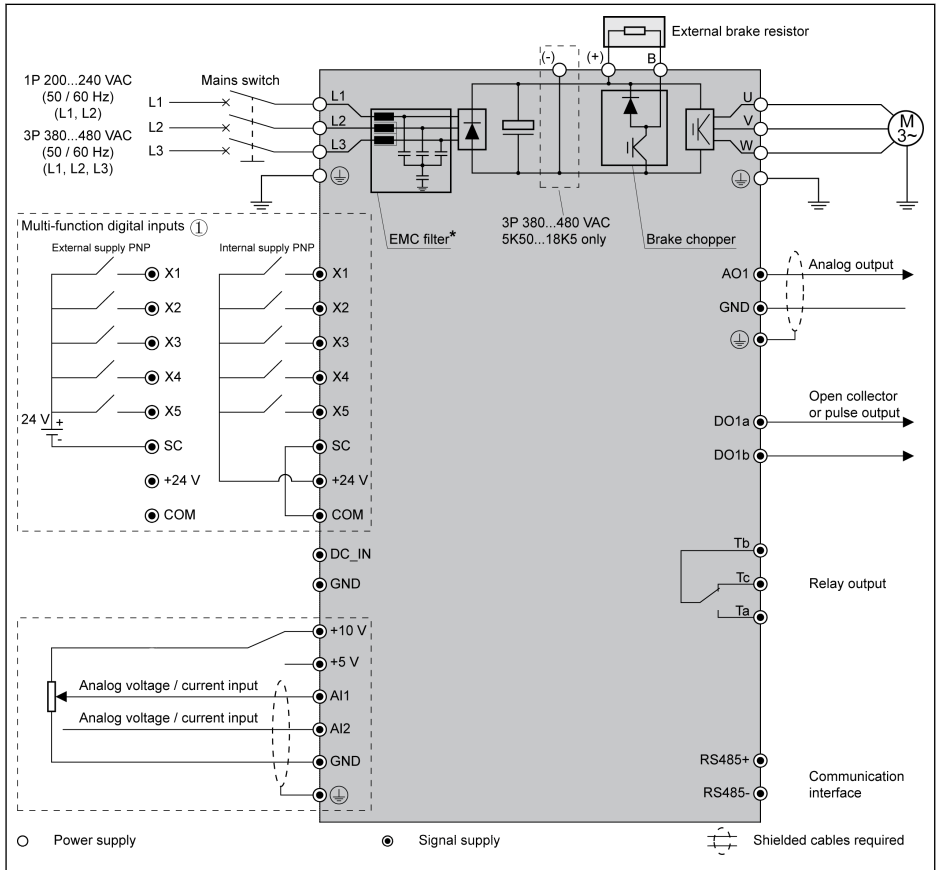

Fig. 8-1: Wiring diagram



- For cable size, fuse, screw torque, see [chapter 8.2 "Cable Specifications"](#) on page 32.
- For terminals, see [chapter 8.3 "Terminals"](#) on page 34.
- ①: NPN modes, see [fig. 8-11 "Digital input X1...X5 NPN / PNP wiring"](#) on page 43.
- *: Can be disconnected by disassembly of a screw.
- Pulse input can **ONLY** be set via 'Multi-function digital input X5'.

8.2 Cable Specifications

8.2.1 Power Cables

Cable specification for international without USA / Canada



- **ONLY USE** copper wires of 90 °C or above according to IEC60364-5-52.
- It is recommended to use shielded cables to connect the motor.
- Model 3K00: **ONLY available** with EFC 3610.
- *: If additional labels available with the terminals of 0K40...7K50, please refer to the torque data on labels.

EFC x610 Model	Fuse (gG)	Power cables installation mode			PE Cable	Torque / Screw
		B1	B2	E		
	[A]	[mm ²]	[mm ²]	[mm ²]	[mm ²]	[N·m / lb·in] (Mx)
0K40	10.0	2.5	2.5	2.5	10.0	1.00* / 9.0 (M3)
0K75	16.0	2.5	2.5	2.5	10.0	1.00* / 9.0 (M3)
1K50	25.0	4.0	4.0	2.5	10.0	1.00* / 9.0 (M3)
2K20	32.0	6.0	6.0	4.0	10.0	1.00* / 9.0 (M3)

Tab. 8-1: 1P 200 VAC fuse and cable dimensions for international without USA / Canada

EFC x610 Model	Fuse (gG)	Power cables installation mode			PE Cable	Torque / Screw
		B1	B2	E		
	[A]	[mm ²]	[mm ²]	[mm ²]	[mm ²]	[N·m / lb·in] (Mx)
0K40	6.0	2.5	2.5	2.5	10.0	1.00* / 9.0 (M3)
0K75	10.0	2.5	2.5	2.5	10.0	1.00* / 9.0 (M3)
1K50	10.0	2.5	2.5	2.5	10.0	1.00* / 9.0 (M3)
2K20	16.0	2.5	2.5	2.5	10.0	1.00* / 9.0 (M3)
3K00	20.0	4.0	4.0	2.5	10.0	1.00* / 9.0 (M3)
4K00	20.0	4.0	4.0	2.5	10.0	1.00* / 9.0 (M3)
5K50	32.0	6.0	6.0	4.0	10.0	1.20* / 10.5 (M4)
7K50	40.0	6.0	10.0	6.0	10.0	1.20* / 10.5 (M4)
11K0	50.0	10.0	10.0	10.0	10.0	1.76 / 15.6 (M4)
15K0	63.0	10.0	10.0	10.0	10.0	1.76 / 15.6 (M4)
18K5	80.0	25.0	25.0	16.0	16.0	3.73 / 33.0 (M5)

Tab. 8-2: 3P 400 VAC fuse and cable dimensions for international without USA / Canada

Cable specification for USA / Canada



- **ONLY USE** copper wires of 75 °C or above according to UL 508C.
- It is recommended to use shielded cables to connect the motor.
- Model 3K00: **ONLY available** with EFC 3610.
- *: If additional labels available with the terminals of 0K40...7K50, please refer to the torque data on labels.

EFC x610 Model	Fuse (Class J) [A]	Power cables [AWG]	PE Cable [AWG]	Torque / Screw [N·m / lb·in] (Mx)
0K40	10.0	14	14	1.00* / 9.0 (M3)
0K75	15.0	14	14	1.00* / 9.0 (M3)
1K50	25.0	10	10	1.00* / 9.0 (M3)
2K20	30.0	10	10	1.00* / 9.0 (M3)

Tab. 8-3: 1P 200 VAC fuse and cable dimensions for USA / Canada

EFC x610 Model	Fuse (Class J) [A]	Power cables [AWG]	PE Cable [AWG]	Torque / Screw [N·m / lb·in] (Mx)
0K40	6	14	14	1.00* / 9.0 (M3)
0K75	10	14	14	1.00* / 9.0 (M3)
1K50	10	14	14	1.00* / 9.0 (M3)
2K20	15	14	14	1.00* / 9.0 (M3)
3K00	20	12	12	1.00* / 9.0 (M3)
4K00	20	12	12	1.00* / 9.0 (M3)
5K50	30	10	10	1.20* / 10.5 (M4)
7K50	40	8	8	1.20* / 10.5 (M4)
11K0	50	8	8	1.76 / 15.6 (M4)
15K0	60	6	6	1.76 / 15.6 (M4)
18K5	80	4	6	3.73 / 33.0 (M5)

Tab. 8-4: 3P 400 VAC fuse and cable dimensions for USA / Canada

8.2.2 Control Cables

The following requirements are applicable to the signal connection wiring:

- Flexible cables with wire end sleeves
- Cable cross-section: 0.2...0.75 mm²
- Cable cross-section when using connectors with insulation sleeves: 0.25...0.75 mm²
- Analog inputs AI1, AI2, +10 V, +5 V and GND: use shielded cables
- RS485 communication: use shielded twisted pair cables

Recommendations on cable insulation stripping:

Please strip the insulation of control cables according to the dimensions given below. Too long stripping may cause short circuit of adjacent cables; too short stripping may lead to cables becoming loose.

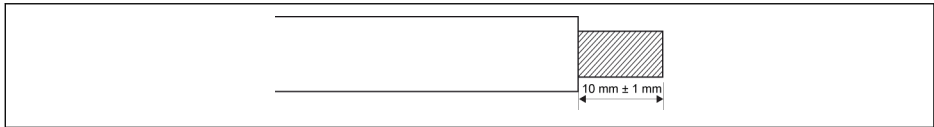

Fig. 8-2: Cable insulation stripping length

8.3 Terminals

8.3.1 Power Terminals

Power Terminals Figure

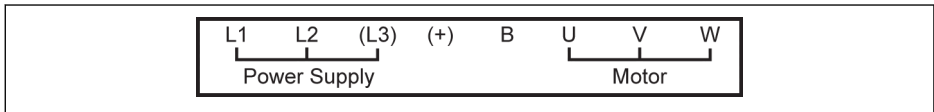

Fig. 8-3: Power terminals (1P 200 VAC 0K40...2K20)

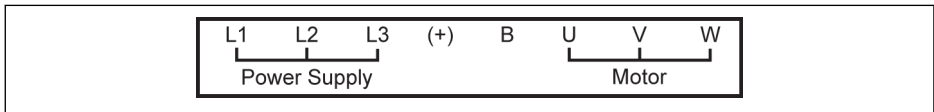

Fig. 8-4: Power terminals (3P 400 VAC 0K40...4K00)

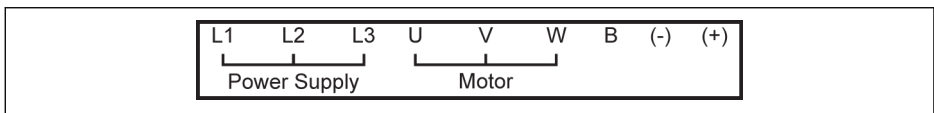

Fig. 8-5: Power terminals (3P 400 VAC 5K50...18K5)

Power Terminals Description

Terminal	Description
L1, L2	Mains supply input terminals
U, V, W	Converter output terminals
B	External brake resistor terminal
(+)	DC positive bus terminal

Tab. 8-5: 1P 200 VAC power terminals description

Terminal	Description
L1, L2, L3	Mains supply input terminals
U, V, W	Converter output terminals
B	External brake resistor terminal
(-)	DC negative bus terminal (only available with 5K50...18K5 models)
(+)	DC positive bus terminal

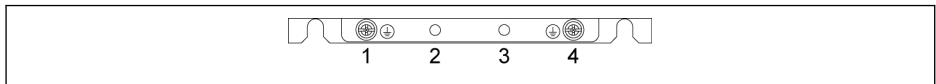
Tab. 8-6: 3P 400 VAC power terminals description**Fig. 8-6:** Grounding and PE terminals

- 1: Grounding terminal for mains cables
- 2: Reserved for PE / shielding adapter (Order additionally)
- 3: Reserved for PE / shielding adapter (Order additionally)
- 4: Grounding terminal for motor cables

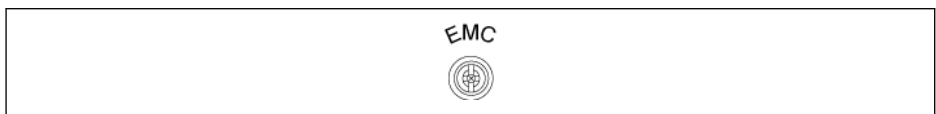
**Fig. 8-7:** Connection screw for internal EMC filter

Internal EMC filter must be disconnected in isolated neutral power system (e.g., IT-Net). Otherwise, the system will be grounded via the capacitor of the EMC filter, which may lead to danger or damage to the frequency converter. The connection screw for the internal EMC filter as shown in the figure above is located at the side of the frequency converter.



With the internal EMC filter disconnected, the specified EMC performance of the frequency converter cannot be reached.

Notes on DC-bus terminals

Wiring of DC-bus in parallel

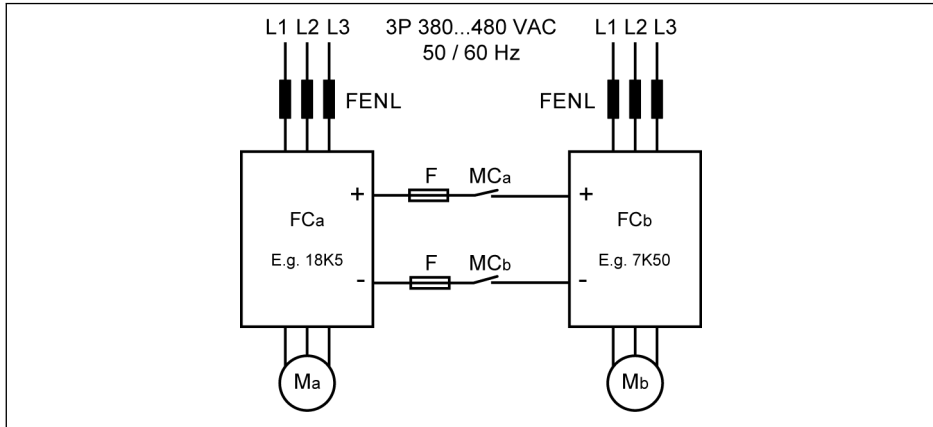

FENL Mains choke

FC_a Frequency converter a

FC_b Frequency converter b

F Fuse

MC_a Magnetic contactor a

MC_b Magnetic contactor b

M_a Motor a

M_b Motor b

Fig. 8-8: Wiring of DC-bus in parallel

Conditions for DC-bus in parallel

- In the above typical application, FC_b runs in generation mode and FC_a runs in motor mode. The power rating of FC_a needs to be 2 levels higher than that of FC_b.

E.g., FC_b is 7K50, FC_a needs to be 18K5 (11K0 and 15K0 in between)

- DC-bus voltage is within the specified range: 457...745 V.
- Use mains choke.
- Select fuses according to FC_b which runs in generator mode, see [chapter "DC-bus fuse specification"](#) on page 39.
- Use external brake resistor to keep the DC-bus voltage within the normal range, especially when converter a is running with light load instead of full load.
- Switch on mains supply to the frequency converters first, and then close MC_a and MC_b after the LED display is active with both frequency converters. The contactor MC_a and MC_b will be switched off by the respective relay output of the frequency converter when an error happens to any of the two frequency converters.

- Select contactors according to the current ratings in [chapter "DC-bus fuse specification" on page 39](#).
- Connect the relay output of FC_a to MC_a, FC_b to MC_b.
- Set [E2.15] = '14: Converter error' to control MC_a by relay output of FC_a.
- Set [E2.15] = '14: Converter error' to control MC_b by relay output of FC_b.



By default, the relay output is inactive when the frequency converter is not running.

Wiring of DC-bus with external DC power supply

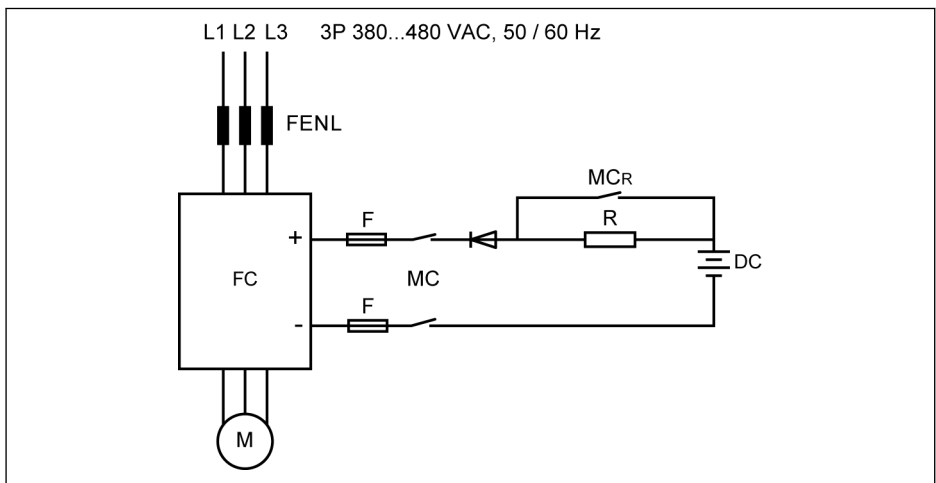

FENL	Mains choke	DC	External DC power supply
FC	Frequency converter	M	Motor
F	Fuse	R	Softstart resistor
MC	Magnetic contactor		
MC_R	Magnetic contactor of softstart resistor		

Fig. 8-9: Wiring of DC-bus with external DC power supply

Conditions for DC-bus with external DC power supply

- DC-bus voltage is within the specified range: 457...745 V.
- Use mains choke.
- Select fuses according to [chapter "DC-bus fuse specification" on page 39](#).
- Use the relay output of the frequency converter to control the contactor MC of the DC-bus. The contactor will be switched off by the relay output once the frequency converter encounters an error.
- Select the external softstart resistor according to the allowed maximum charging current defined in the table below.

Model	Maximum charging current [A]
5K50	30
7K50	50
11K0	70
15K0	120
18K5	120

Tab. 8-7: Allowed maximum charging current through rectifier

- Set [E2.15] = '14: Converter error' to control MC by relay output of FC. Connect relay output of FC to MC.



By default, the relay output is inactive when there is no error. Please use an additional device to keep the relay output status when the frequency converter is switched off without power input. Without such a device, the relay output will be restored to be inactive as the frequency converter will lose the control.

WARNING

The external softstart circuit must be properly controlled to avoid direct charging of the capacitor with external DC power supply, especially when DC power supply is the only power source for the frequency converter.

- Use a diode to ensure the current is always in the direction of flowing-in the frequency converter.

DC-bus fuse specification

The fuse rating depends on the fuse type (gG) and the temporary overload capability of the frequency converter.



If no overload happens in an application, the fuses can be selected directly according to the power rating of the frequency converter.

Recommended fuse ratings at DC-bus voltage of 690 V are shown in the table below.

Model	Motor power [kW]	Motor efficiency	DC-current [A]	gG fuses [A]
5K50	5.5	85.8 %	12.5	16
7K50	7.5	87.1 %	16.8	25
11K0	11	88.5 %	24.2	35
15K0	15	89.5 %	32.7	50
18K5	18.5	90.1 %	40.0	50

Tab. 8-8: Recommended fuse ratings

$$I_{DC} = P_{Motor} / (1.35 \times U_{Line} \times \eta_{Motor})$$

The recommended fuse rated current is calculated based on the selected motor. In actual application, please check the value according to the equation above and the actual motor efficiency.

8.3.2 Control Terminals

Control terminals figure

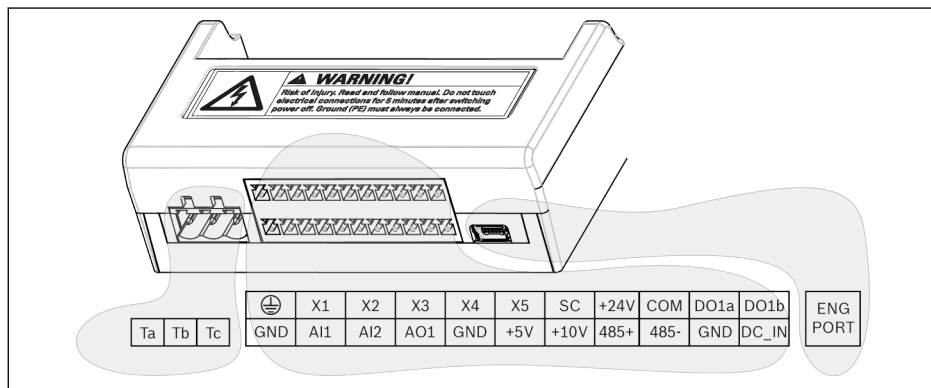



Fig. 8-10: Control circuit terminals

Control terminals description

Digital inputs

Terminal	Signal function	Description	Signal requirement
X1...X5	Multi-function digital inputs	See Group E1	Inputs via opto-electric couplers: 24 VDC, 8 mA / 12 VDC, 4 mA Pulse input: Max. 50.0 kHz
X5 (multiplex)	Pulse input		
SC	Shared connection	Shared connection for isolation optocouplers	–
+24 V	Power supply for digital inputs	COM is reference	Max. output current: 100 mA
COM		Isolated from GND	

Analog inputs

Terminal	Signal function	Description	Signal requirement
+10 V	Power supply for AI1, AI2	GND is reference	Max. output current: 30 mA
+5 V			Max. output current: 10 mA
AI1	Analog voltage input 1/ Analog current input 1	Analog voltage / current inputs are used as external frequency setting channels	Voltage input range: 0/2...10 V Input impedance: 40 k Ω Resolution: 1/1000
AI2	Analog voltage input 2/ Analog current input 2	To switch between voltage and current or to set the input related functions, see Group E1	Current input range: 0/4...20 mA Input impedance: 499 Ω Resolution: 1/1000
GND	Shared connection	Isolated from COM	–
	Shielding connection	Connected with grounding terminals on heatsink internally	–

Digital outputs

Terminal	Signal function	Description	Signal requirement
DO1a	Open collector output or pulse output	See Group E2 COM is reference	Open collector output: Max. 30 VDC, 50 mA Pulse output Max. frequency: 32.0 kHz
DO1b			
Ta	Relay changeover contacts	See Group E2	Rated capacity: 250 VAC, 3 A; 30 VDC, 3 A
Tc			
Tb			

Analog outputs

Terminal	Signal function	Description	Signal requirement
AO1	Analog multiple function output	See Group E2	Voltage output: 0/2...10 V Current output: 0/4...20 mA Output impedance 138 Ω
GND	Shared connection	Isolated from COM	–

Modbus communication

Terminal	Signal function	Description	Signal requirement
485+	Positive differential signal	GND is reference	–
485-	Negative differential signal		

External power supply

Terminal	Signal function	Description	Signal requirement
DC_IN	Auxiliary power supply for control board	External +24 V supply input for control and panel boards (NOT used for digital inputs)	Rated capacity: 24 V (-10...+15 %) 200 mA
GND	Shared connection	Isolated from COM	–

Digital input X1...X5 NPN / PNP wiring

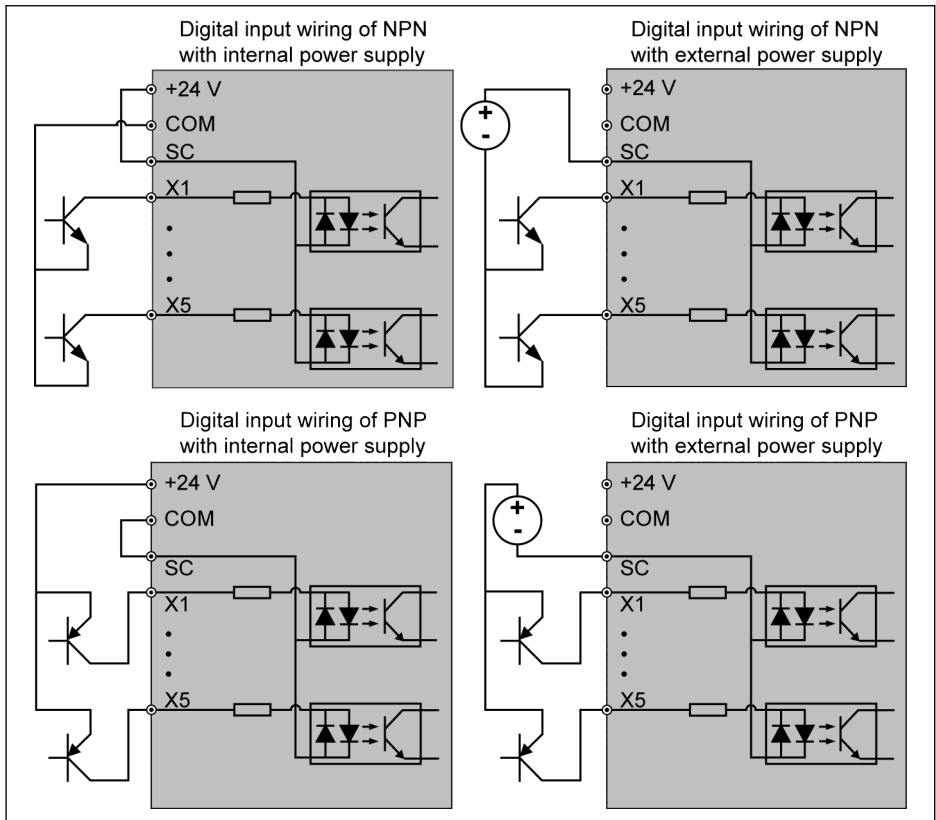

Fig. 8-11: Digital input X1...X5 NPN / PNP wiring

Digital output DO1a, DO1b load pull-up / pull-down wiring

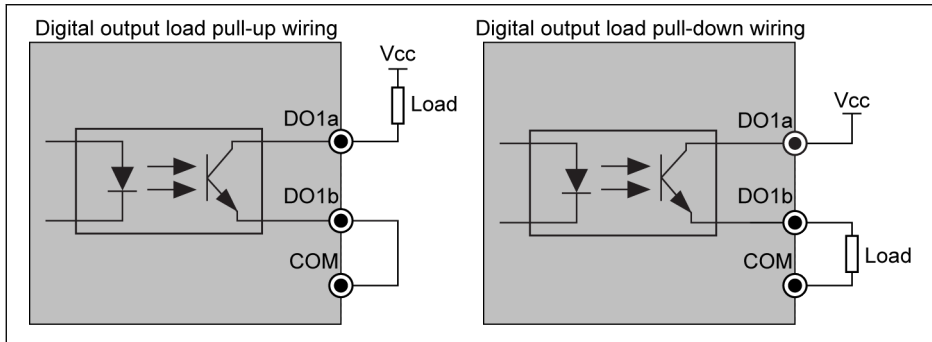

Fig. 8-12: Digital output DO1a, DO1b load pull-up / pull-down wiring



Vcc supply can be provided externally or internally.

For internal supply, **ONLY USE +24 V** and **NEVER USE +10 V** or **+5 V**!

Analog input terminals (AI1, AI2, +10 V, +5 V, Earth and GND)

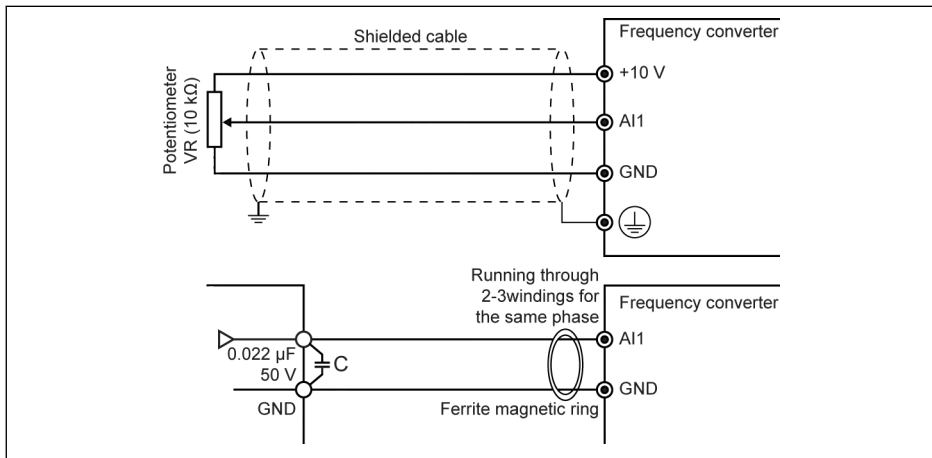

Fig. 8-13: Analog input terminals



- The figures for AI2 and +5 V are similar to the figure above.
- Incorrect operation may occur due to interference on the analog signal. In such cases, connect a capacitor and ferrite magnetic ring at the output side of the analog signal, as shown above.

Notes on DC_IN terminal

Converter in running status: Converter stops with error 'UE-1' at AC power loss

Conditions	Description
DC_IN power is available	'UE-1' remains to be displayed on the panel 'Power loss restart' function does NOT work Converter can NOT be started by any command source Limited* Parameters can be viewed but can NOT be modified
DC_IN power is unavailable	Converter panel blackout after a short time
AC power resumes	Converter will remain in stop state, 'UE-1' can be reset 'Power loss restart' function works

Tab. 8-9: Power loss in running status

Converter in stopped status: 'p.OFF' will be displayed at AC power loss

Conditions	Description
DC_IN power is available	'p.OFF' remains to be displayed on the panel Converter can NOT be started by any command source Limited* Parameters can be viewed but can NOT be modified
DC_IN power is unavailable	Converter panel blackout after a short time
AC power resumes	Converter will remain in stop state, 'p.OFF' disappears automatically

Tab. 8-10: Power loss in stopped status

Limited* Parameters

Code	Name	Code	Name
b0.00	Access authority setting	E9.01	Automatic error reset interval
E0.45	Power loss restart setting	E9.05	Last error type
E0.46	Power loss restart delay	E9.06	Second last error type
E8.00	Communication protocol	E9.07	Third last error type
E8.01	Communication error detection time	E9.10	Output frequency at last error
E8.02	Communication error protection mode	E9.11	Setting frequency at last error
E8.10	Modbus baud rate	E9.12	Output current at last error
E8.11	Modbus data format	E9.13	Output voltage at last error
E8.12	Modbus local address	E9.14	DC bus voltage at last error
E9.00	Automatic error reset attempts	E9.15	Power module temperature at last error

Tab. 8-11: Limited parameters

9 Electromagnetic Compatibility (EMC)

9.1 EMC Requirements

9.1.1 General Information

The electromagnetic compatibility (EMC) or electromagnetic interference (EMI) includes the following requirements:

- Sufficient noise immunity of an electric installation or an electric device against external electric, magnetic or electromagnetic interference via lines or through air.
- Sufficiently low noise emission of electric, magnetic or electromagnetic noise of an electric installation or an electric device to other surrounding devices via lines or through air.

9.1.2 Noise Immunity in the Drive System

Basic structure for noise immunity

The figure below illustrates the interference for definition of noise immunity requirements in the drive system.

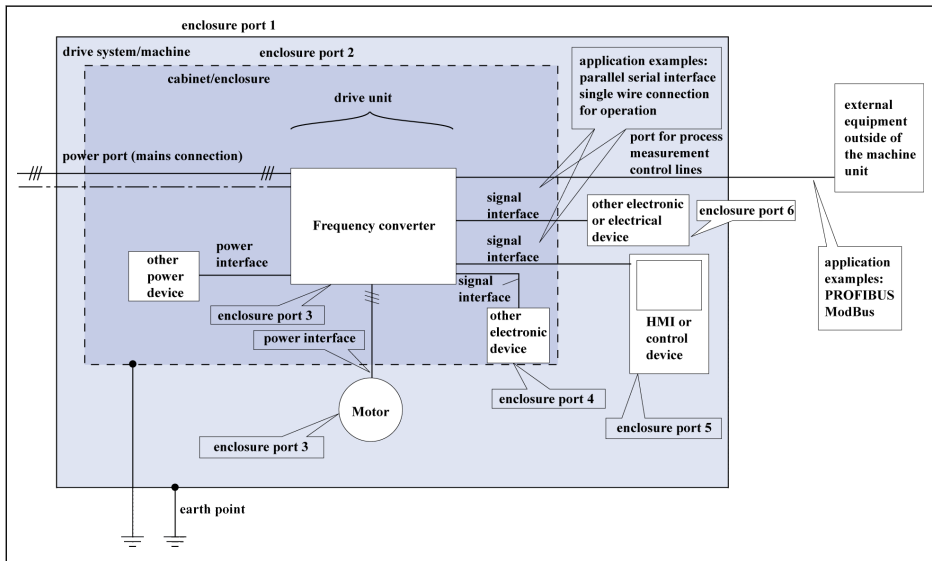

Fig. 9-1: Noise immunity in the drive system

Minimum immunity requirements for PDSs intended for use in the second environment

Port	Phenomenon	Basic standard for test method	Level	Performance (acceptance criterion)
Enclosure port	ESD	IEC 61000-4-2	4 kV CD or 8 kV AD if CD impossible	B
	Radio-frequency electromagnetic field, amplitude modulated	IEC 61000-4-3	80...1000 MHz 10 V/m 1.4...0 GHz 3 V/m 2.0...2.7 GHz 1 V/m 80 % AM (1 kHz)	A
Power ports	Fast transient-burst	IEC 61000-4-4	2 kV/5 kHz	B
	Surge 1.2/50 μ s, 8/20 μ s	IEC 61000-4-5	1 kV ^a , 2 kV ^b	B
	Conducted radio-frequency common mode	IEC 61000-4-6	0.15...80 MHz 10 V 80 % AM (1 kHz)	A
Power interfaces	Fast transient-burst	IEC 61000-4-4	2 kV/5 kHz Capacitive clamp	B
Signal interfaces	Fast transient-burst	IEC 61000-4-4	1 kV/5 kHz Capacitive clamp	B
	Conducted radio-frequency common mode	IEC 61000-4-6	0.15...80 MHz 10 V 80 % AM (1 kHz)	A
Ports of process measurement control lines	Fast transient-burst	IEC 61000-4-4	2 kV/5 kHz Capacitive clamp	B
	Conducted radio-frequency common mode	IEC 61000-4-6	0.15...80 MHz 10 V 80 % AM (1 kHz)	A

Tab. 9-1: Minimum immunity requirements for PDSs intended for use in the second environment

Minimum immunity requirements for PDSs intended for use in the first environment

Port	Phenomenon	Basic standard for test method	Level	Performance (acceptance criterion)
Enclosure port	ESD	IEC 61000-4-2	4 kV CD or 8 kV AD if CD impossible	B
	Radio-frequency electromagnetic field, amplitude modulated	IEC 61000-4-3	80 ~ 1000 MHz 3 V/m 1.4 ~ 2.0 GHz 3 V/m 2.0 ~ 2.7 GHz 1 V/m 80 % AM (1 kHz)	A
Power ports	Fast transient-burst	IEC 61000-4-4	1 kV/5 kHz	B
	Surge 1.2/50 μ s, 8/20 μ s	IEC 61000-4-5	1 kV ^a , 2 kV ^b	B
	Conducted radio-frequency common mode	IEC 61000-4-6	0.15 ~ 80 MHz 3 V 80 % AM (1 kHz)	A
Power interfaces	Fast transient-burst	IEC 61000-4-4	1 kV/5 kHz Capacitive clamp	B
Ports of process measurement control lines	Fast transient-burst	IEC 61000-4-4	0.5 kV/5 kHz Capacitive clamp	B
	Conducted radio-frequency common mode	IEC 61000-4-6	0.15 ~ 80 MHz 3 V 80 % AM (1 kHz)	A

Tab. 9-2: Minimum immunity requirements for PDSs intended for use in the first environment

- CD: Contact discharge
- AD: Air discharge
- AM: Amplitude modulation
- ^a: Coupling line to line
- ^b: Coupling line to earth



Category C1 is only for conducted emission, radiated emission needs checking with metallic cabinet. For installation, see [chapter 9.3 "EMC Measures for Design and Installation"](#) on page 55.

Evaluation criterion

Evaluation criterion	Explanation (abbreviated form from EN 61800-3)
A	Deviations within allowed range
B	Automatic recovery after interference
C	Switched off without automatic recovery. Device remains undamaged

Tab. 9-3: Evaluation criterion

9.1.3 Noise Emission of the Drive System

Causes of noise emission

Controlled variable-speed drives contain converters containing snappy semiconductors. The advantage of modifying the speed with high precision is achieved by means of pulse width modulation of the converter voltage. This can generate sinusoidal current with variable amplitude and frequency in the motor.

The steeper voltage rises, the higher clock rate and the resulting harmonics cause unwanted but physically unavoidable emission of interference voltage and interference fields (wide band interference). The interference mainly is asymmetric interference against ground.

The propagation of this interference strongly depends on:

- configuration of the connected drives
- number of the connected drives
- conditions of mounting
- site of installation
- radiation conditions
- wiring and installation

If the interference gets from the device to the connected lines in unfiltered form, these lines can radiate the interference into the air (antenna effect). This applies to power lines, too.

Limit values for line-based disturbances

According to IEC EN 61800-3 or CISPR 11 (corresponds to EN 55011), the limit values in the table below are distinguished. For this documentation both standards are combined in the limit value classes A2.1 to B1.

IEC / EN 61800-3	CISPR 11	Explanation	In this document	Curves of limit value characteristic
Category C4 2 nd environment	None	<p>One of the following 3 requirements must have been fulfilled:</p> <ul style="list-style-type: none"> • Mains connection current > 400 A, IT mains or required dynamic drive behavior not reached by means of EMC filter. • Adjust limit values to use and operation on site. • User has to carry out and provide evidence of EMC planning. 	None	–
Category C3 2 nd environment	Class A; group 2, I>100 A	Limit value in industrial areas to be complied with for applications operated at supply mains with nominal current > 100 A	A2.1	1.1 1.2
Category C3 2 nd environment	Class A; group 2, I≤100 A	Limit value in industrial areas to be complied with for applications operated at supply mains with nominal current ≤ 100 A	A2.2	2.1 2.2
Category C2 1 st environment	Class A; group 1	Limit value in residential area or at facilities at low-voltage mains supplying buildings in residential areas to be complied with	A1	3.1 3.2
Category C1 1 st environment	Class B; group 1	Limit value in residential areas to be complied with	B1	4.1 4.2

Tab. 9-4: Limit values for line-based disturbances

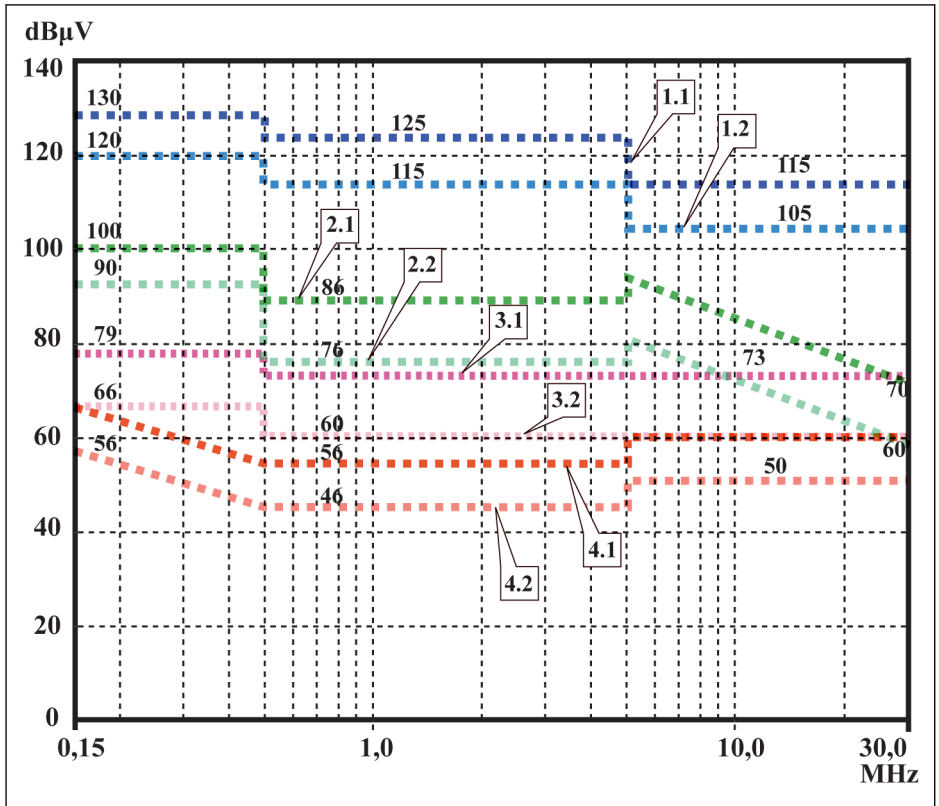

- 1.1 C3** 2nd environment, QP, I > 100 A (class A, group 2, I > 100 A)
- 1.2 C3** 2nd environment, AV, I > 100 A (class A, group 2, I > 100 A)
- 2.1 C3** 2nd environment, QP, I ≤ 100 A (class A, group 2, I ≤ 100 A)
- 2.2 C3** 2nd environment, AV, I ≤ 100 A (class A, group 2, I ≤ 100 A)
- 3.1 C2** 1st environment, QP (1st environment, even if source of interference in 2nd environment) (class A, group 1)
- 3.2 C2** 1st environment, AV (1st environment, even if source of interference in 2nd environment) (class A, group 1)
- 4.1 C1** 1st environment, QP (1st environment, even if source of interference in 2nd environment) (class B, group 1)
- 4.2 C1** 1st environment, AV (1st environment, even if source of interference in 2nd environment) (class B, group 1)

Fig. 9-2: Limit values for line-based disturbances (IEC 61800-3); limit characteristic through frequency range



- Limit value for 1st environment is also relevant, if source of interference of 2nd environment affects 1st environment
- Designations “class” and “group” according to CISPR 11
- QP: measuring method quasi peak measurement
- AV: measuring method arithmetic averaging

Second Environment, Industrial Area

Facilities not directly connected to a low-voltage mains to supply buildings in residential areas.

If the limit values in an industrial area separated from public supply by a transformer station only have to be complied with at the property boundary or in the neighboring low-voltage mains, the filter might not be necessary. In the vicinity such as measuring sensors, measuring lines or measuring devices, it is normally required to use the interference suppression filter.

Increasing the noise immunity of a sensitive device can often be the economically better solution compared to measures of interference suppression at the drive system of installation.

First Environment

Environment containing residential areas and facilities directly connected, without interstage transformer, to a low-voltage mains supplying buildings in residential areas.

Medium-sized manufacturing plants and industrial establishments can be connected to the public low-voltage mains together with residential buildings. In this case there is a high risk for radio and television reception if there are not any measures for radio interference suppression taken. Therefore, the indicated measures are generally recommended.

Nominal Current of Supply Mains

The nominal current of the supply mains ($> 100 \text{ A}$ or $\leq 100 \text{ A}$) is specified by the local power supply company at the connection point of the mains. For industrial companies, for example, such connection points are the interconnecting stations from the power supply company.

Since it is impossible to obtain the lower limit values for residential areas with all applications by means of usual measures (like in the case of large and electrically not closed installations, longer motor cables or a large number of drives), the following note included in EN 61800-3 has to be observed.



According to standard EN 61800-3:

- The drive system of standard EFC x610 with internal EMC filter, is product of category C3 and applicable to industrial environment.
- The drive system of EFC x610 with external EMC filter, is product of category C1 and applicable to domestic environment.

WARNING

Frequency Converter EFC x610 with external EMC filter can be used in a domestic environment (category C1), which however may cause radio interference. In this case, supplementary mitigation measures may be required.

See the following chapters for the limit classes (as per categories C1, C2, C3, C4 according to EN 61800-3) which can be reached for Bosch Rexroth Frequency Converter EFC x610.

9.2 Ensuring the EMC Requirements

Standards and Laws

On the European level there are the EU Directives. In the EU states these Directives are transformed into laws valid on a national level. The relevant directive for EMC is EU Directive 2004/108/EC which was transformed on the national level in Germany into the law EMVG (“Law concerning electromagnetic compatibility of devices”) of 2008-02-26.

EMC Properties of Components

Drive and control components by Rexroth are designed and built, in accordance with the present state-of-the-art of standardization, according to legal regulations of the EU Directive EMC 2004/108/EC and the German law.

The compliance with EMC standards was tested by means of a typical arrangement with a test setup conforming to standard with the indicated external EMC filter.

- Category C3 requirements according to product standard EN 61800-3 have been complied with for EFC x610.
- Minimum immunity requirements in the second environment according to product standard EN 61800-3 have been complied with for EFC x610.

Applicability for End Product

Measurements of the drive system with an arrangement typical for the system are not in all cases applicable to the status in a machine or installation. Noise immunity and noise emission strongly depend on:

- configuration of the connected drives
- number of the connected drives
- conditions of mounting
- site of installation
- radiation conditions
- wiring and installation

In addition, the required measures depend on the requirements of electric safety technology and economic efficiency in the application.

In order to prevent interference as far as possible, please read through and follow the detailed descriptions regarding on mounting and installation in this documentation.

Cases to Distinguish for Declaration of EMC Conformity

For validity of the harmonized standards, we distinguish the following cases:

- Case 1: Delivery of the drive system.

According to the regulations, EFC x610 drive system is complied with product standard EN 61800-3 C3. The drive system is listed in the declaration of EMC conformity. This fulfills the legal requirements according to EMC directive.

- Case 2: Acceptance test of a machine or installation with the installed drive systems.

The product standard for the respective type of machine/installation, if existing, applies to the acceptance test of the machine or installation. In the last years, some new product standards were created at present.

These new product standards contain references to the product standard EN 61800-3 for drives or specify higher-level requirements demanding increased filter and installation efforts. When the machine manufacturer wants to put the machine/installation into circulation, the product standard relevant to his machine/ installation has to be complied with for his end product "machine/installation". The authorities and test laboratories responsible for EMC normally refer to this product standard.

This documentation specifies the EMC properties which can be achieved, in a machine or installation, with a drive system consisting of the standard components.

It also specifies the conditions under which the indicated EMC properties can be achieved.

9.3 EMC Measures for Design and Installation

9.3.1 Rules for Design of Installations with Drive Controllers in Compliance with EMC

The following rules are the basics for designing and installing drives in compliance with EMC:

Mains Filter

Correctly use a mains filter recommended by Rexroth for radio interference suppression in the mains supply of the drive system.

Control Cabinet Grounding

Connect all metal parts of the cabinet with one another over the largest possible surface area to establish a good electric connection. This, too applies to the mounting of the external mains filter. If required, use serrated washers which cut through the paint surface. Connect the cabinet door to the control cabinet using the shortest possible grounding straps.

Line Routing

Avoid coupling routes between lines with high potential of noise and noise-free lines; therefore, signal, mains and motor lines and power cables have to be routed separately from another. Minimum distance: 10 cm. Provide separating sheets between power and signal lines. Ground separating sheets several times.

The lines with high potential of noise include:

- Lines at the mains connection (incl. synchronization connection)
- Lines at the motor connection
- Lines at the DC-bus connection

Generally, interference injections are reduced by routing cables close to grounded sheet steel plates. For this reason, cables and wires should not be routed freely in the cabinet, but close to the cabinet housing or mounting panels. Separate the incoming and outgoing cables of the radio interference suppression filter.

Interference Suppression Elements

Provide the following components in the control cabinet with interference suppression combinations:

- Contactors
- Relays
- Solenoid valves
- Electromechanical operating hours counters

Connect these combinations directly at each coil.

Twisted Wires

Twist unshielded wires belonging to the same circuit (feeder and return cable) or keep the surface between feeder and return cable as small as possible. Wires that are not used have to be grounded at both ends.

Lines of Measuring Systems

Lines of measuring systems must be shielded. Connect the shield to ground at both ends and over the largest possible surface area. The shield may not be interrupted, e.g. using intermediate terminals.

Digital Signal Lines

Ground the shields of digital signal lines at both ends (transmitter **and** receiver) over the largest possible surface area and with low impedance. This avoids low frequency interference current (in the mains frequency range) on the shield.

Analog Signal Lines

Ground the shields of analog signal lines at one end (transmitter **or** receiver) over the largest possible surface area and with lower impedance. This avoids low frequency interference current (in the mains frequency range) on the shield.

Connection of Mains Choke

Keep connection lines of the mains choke at the drive controller as short as possible and twist them.

Installation of Motor Power Cable

- Use shielded motor power cable or run motor power cables in a shielded duct
- Use the shortest possible motor power cable
- Ground shield of motor power cable at both ends over the largest possible surface area to establish a good electric connection
- It is recommended to run motor lines in shielded form inside the control cabinet
- Do not use any steel-shielded lines
- The shield of the motor power cable must not be interrupted by mounted components, such as output chokes, sine filter or motor filters

9.3.2 EMC-optimal Installation in Facility and Control Cabinet

General Information

For EMC-optimal installation, a special separation of the interference-free area (mains connection) and the interference-susceptible area (drive components) is recommended, as shown in the figures below.



- For EMC-optimal installation in the control cabinet, use a separate control cabinet panel for the drive components.
 - Frequency converters need to be mounted in metal cabinet and connected to power supply with grounding.
 - For the EMC test of standard frequency converters with internal EMC filters, the following cables were used between the motor and the frequency converter:
 - 0K40...4K00 model: 15 m (meets requirements of category C3)
 - 5K50...18K5 model: 30 m (meets requirements of category C3)
 - For the EMC test of frequency converters with external EMC filters, the following cables were used between the motor and the frequency converter:
 - 50 m: meets requirements of category C3
 - 50 m: meets requirements of category C2
 - 10 m: meets requirements of category C1Output choke is required for category C1 with 10 m cables. Please contact with Rexroth distributors for information on chokes.
 - For the end application system with frequency converters, the conformity of EMC directions needs to be confirmed.
-

Division into Areas (zones)

Exemplary arrangements in the control cabinet: See [chapter 9.3.3 "Control Cabinet Mounting according to Interference Areas – Exemplary Arrangements"](#) on page 59.

We distinguish three areas:

1. Interference-free area of control cabinet (**area A**):
 - Supply feeder, input terminals, fuse, main switch, mains side of mains filter for drives and corresponding connecting lines
 - All components that are not electrically connected with the drive system
2. Interference-susceptible area (**area B**):
 - Mains connections between drive system and mains filter for drives, mains contactor
 - Interface lines of drive controller
3. Strongly interference-susceptible area (**area C**):
 - Motor power cables including single cores

Never run lines of one of these areas in parallel with lines of another area so that there is not any unwanted interference injection from one area to the other and that the filter is jumped with regard to high frequency. Use the shortest possible connecting lines.

Recommendation for complex systems: Install drive components in one cabinet and the control units in a second, separate cabinet.

Badly grounded control cabinet doors act as antennas. Therefore, connect the control cabinet doors to the cabinet on top, in the middle and on the bottom via short equipment grounding conductors with a cross section of at least 6 mm² or, even better, via grounding straps with the same cross section. Make sure connection points have good contact.

9.3.3 Control Cabinet Mounting according to Interference Areas – Exemplary Arrangements

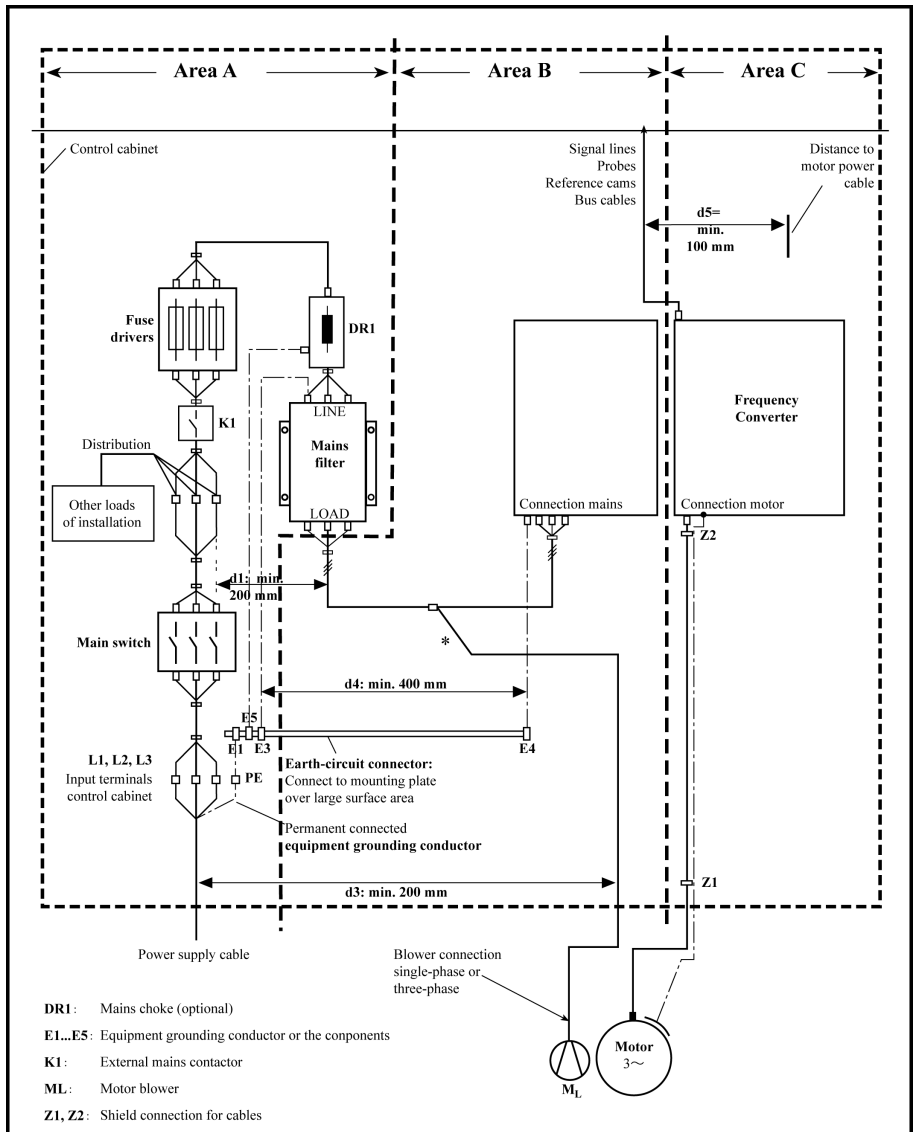

Fig. 9-3: Control cabinet mounting according to interference areas – exemplary arrangements

9.3.4 Design and Installation in Area A – Interference-free Area of Control Cabinet

Arrangement of the Components in the Control Cabinet

Comply with a distance of at least 200 mm (distance d1 in the figure):

- Between components and electric elements (switches, pushbuttons, fuses, terminal connectors) in the interference-free area A and the components in the two other areas B and C

Comply with a distance of at least 400 mm (distance d4 in the figure):

- Between magnetic components (such as transformers, mains chokes and DC-bus chokes that are directly connected to the power connections of the drive system) and the interference-free components and lines between mains and filter including the mains filter in area A

If these distances are not kept, the magnetic leakage fields are injected to the interference-free components and lines connected to the mains and the limit values at the mains connection are exceeded in spite of the installed filter.

Cable Routing of the Interference-free Lines to the Mains Connection

Comply with a distance of at least 200 mm (distance d1 and d3 in the figure):

- Between supply feeder or lines between filter and exit point from the control cabinet in area A and the lines in area B and C

If this is impossible, there are two alternatives:

1. Install lines in shielded form and connect the shield at several points (at least at the beginning and at the end of the line) to the mounting plate or the control cabinet housing over a large surface area.
2. Separate lines from the other interference-susceptible lines in areas B and C by means of a grounded distance plate vertically attached to the mounting plate.

Install the shortest possible lines within the control cabinet and install them directly on the grounded metal surface of the mounting plate or of the control cabinet housing.

Mains supply lines from areas B and C must not be connected to the mains without a filter.



In case you do not observe the information on cable routing given in this section, the effect of the mains filter is totally or partly neutralized. This will cause the noise level of the interference emission to be higher within the range of 150 kHz to 40 MHz and the limit values at the connection points of the machine or installation will thereby be exceeded.

Routing and Connecting a Neutral Conductor (N)

If a neutral conductor is used together with a three-phase connection, it must not be installed unfiltered in areas B and C, in order to keep interference off the mains.

Motor Blower at Mains Filter

Single-phase or three-phase supply lines of motor blowers, that are usually routed in parallel with motor power cables or interference-susceptible lines, must be filtered:

- In frequency converter with **only infeeding supply units**, via the available three phase filter of the frequency converter

When switching power off, make sure the blower is not switched off.

Loads at Mains Filter of frequency converter

- Only operate allowed loads at the mains filter of the frequency converter!

Shielding Mains Supply Lines in Control Cabinet

If there is a high degree of interference injection to the mains supply line within the control cabinet, although you have observed the above instructions (to be found out by EMC measurement according to standard), proceed as follows:

- Only use shielded lines in area A
- Connect shields to the mounting plate at the beginning and the end of the line by means of clips

The same procedure may be required for long cables of more than 2 m between the point of power supply connection of the control cabinet and the filter within the control cabinet.

Mains Filters for AC Drives

Ideally, mount the external mains filter on the parting line between area A and B. Make sure the ground connection between filter housing and housing of the drive controllers has good electrically conductive properties.

If **single-phase** loads are connected on the load side of the external filter, their current may be a maximum of 10 % of the three-phase operating current. A highly imbalanced load of the external filter would deteriorate its interference suppression capacity.

If the mains voltage is higher than 480 V, connect the external filter to the output side of the transformer instead of the supply side of the transformer.

Grounding

In the case of bad ground connections in the installation, the distance between the lines to the grounding points E1, E2 in area A and the other grounding points of the frequency converter should be at least $d_4 = 400$ mm, in order to minimize interference injection from ground and ground cables to the power input lines.

See also "[Division into Areas \(zones\)](#)" on page 58.

Point of Connection for Environment Grounding Conductor at Machine, Installation, Control Cabinet

The equipment grounding conductor of the power cable of the machine, installation or control cabinet has to be permanently connected at point PE and have a cross section of at least 10 mm² or to be complemented by a second equipment grounding conductor via separate terminal connectors (according to EN 61800-5-1: 2007, section 4.3.5.4). If the cross section of the outer conductor is bigger, the cross section of the equipment grounding conductor must be accordingly bigger.

9.3.5 Design and Installation in Area B – Interference-susceptible Area of Control Cabinet

Arranging Components and Lines

Modules, components and lines in area B should be placed at a distance of at least $d_1 = 200$ mm from modules and lines in area A.

Alternative: Shield modules, components and lines in area B by distance plates mounted vertically on the mounting plate from modules and lines in area A or use shield lines.

Only connect control voltage connections in the frequency converter to the mains via a mains filter. See "[Division into Areas \(zones\)](#)" on page 58.

Install the shortest possible lines between drive controller and filter.

Control Voltage or Auxiliary Voltage Connection

Only in exceptional cases should you connect power supply unit and fusing for the control voltage connection to phase and neutral conductor. In this case, mount and install these components in area A far away from area B and C of the frequency converter.

Run the connection between control voltage connection of the frequency converter and power supply unit used through area B over the shortest distance.

Line Routing

Run the lines along grounded metal surfaces, in order to minimize radiation of interference fields to area A (transmitting antenna effect).

9.3.6 Design and Installation in Area C – Strongly Interference-susceptible Area of Control Cabinet

Area C mainly concerns the motor power cables, especially at the connection point of the drive controller.

Influence of the Motor Power Cable

The longer the motor cable, the greater its leakage capacitors. To comply with a certain EMC limit value, the allowed leakage capacitance of the mains filter is limited.

- Run the shortest possible motor power cables.

Routing the Motor Power Cables and Motor Encoder Cables

Route the motor power cables and motor encoder cables along grounded metal surfaces, both inside the control cabinet and outside of it, in order to minimize radiation of interference fields. If possible, route the motor power cables and motor encoder cables in metal-grounded cable ducts.

Route the motor power cables and motor encoder cables

- with a distance of at least **d5 = 100 mm** to interference-free lines, as well as to signal cables and signal lines
(alternatively separated by a grounded distance plate)
- in separate cable ducts, if possible

Routing the Motor Power Cables and Mains Connection Lines

For frequency converters (drive controllers with individual mains connection), route motor power cables and (unfiltered) mains connection lines **in parallel for a maximum distance of 300 mm**. After that distance, route motor power cables and power supply cables in opposite directions and preferably in separate **cable ducts**.

Ideally, the outlet of the motor power cables at the control cabinet should be provided in a distance of at least **d3 = 200 mm** from the (filtered) power supply cable.

9.3.7 Ground Connections

Housing and Mounting Plate

By means of appropriate ground connections, it is possible to avoid the emission of interference, because interference is discharged to ground on the shortest possible way.

Ground connections of the metal housings of EMC-critical components (such as filters, devices of the frequency converter, connection points of the cable shields, devices with microprocessor and switching power supply units) have to be well contacted over a large surface area. This also applies to all screw connections between mounting plate and control cabinet wall and to the mounting of a ground bus to the mounting plate. The best solution is to use a zinc-coated mounting plate. Compared to a lacquered plate, the connections in this area have a good long-time stability.

Connection Elements

For lacquered mounting plates, always use screw connections with tooth lock washers and zinc-coated, tinned screws as connection elements. At the connection points, remove the lacquer so that there is safe electric contact over a large surface area. You achieve contact over a large surface area by means of bare connection surfaces or several connection screws. For screw connections, you can establish the contact to lacquered surfaces by using tooth lock washers.

Metal Surfaces

Always use connection elements (screws, nuts, plain washers) with good electroconductive surface.

Bare zinc-coated or tinned metal surfaces have **good electroconductive properties**.

Anodized, yellow chromated, black gunmetal finish or lacquered metal surfaces have **bad electroconductive properties**.

Ground Wires and Shield Connections

For connecting ground wires and shield connections, it is not the cross section but the size of contact surface that is important, as the high-frequency interference current mainly flow on the surface of the conductor.

9.3.8 Installing Signal Lines and Signal Cables

Line Routing

The following measures are recommend:

- Route signal and control lines separately from the power cables with a minimum distance of $d_5 = 100 \text{ mm}$ (see "[Division into Areas \(zones\)](#)" on page 58) or with a grounded separating sheet. The optimum way is to route them in separate cable ducts. If possible, lead signal lines into the control cabinet at one point only.
- If signal lines are crossing power cables, route them in an angle of 90° in order to avoid interference injection.
- Ground spare cables, that are not used and have been connected, at least at both ends so that they do not have any antenna effect.
- Avoid unnecessary line lengths.
- Run cables as close as possible to grounded metal surfaces (reference potential). The ideal solution are closed, grounded cable ducts or metal pipes which, however, is only obligatory for high requirements (sensitive instrument leads).
- Avoid suspended lines or lines routed along synthetic carries, because they are functioning like reception antennas (noise immunity) and like transmitting antennas (emission of interference). Exceptional cases are flexible cable tracks over short distances of a maximum of 5 m.

Shielding

Connect the cable shield immediately at the devices in the shortest and most direct possible way and over the largest possible surface area.

Connect the shield of analog signal lines at one end over a large surface area, normally in the control cabinet at the analog device. Make sure the connection to ground/housing is short and over a large surface area.

Connect the shield of digital signal lines at both ends over a large surface area and in short form. In the case of potential differences between beginning and end of the line, run an additional bonding conductor in parallel. This prevents compensating current from flowing via the shield. The guide value for the cross section is 10 mm^2 .

You absolutely have to equip separate connections with connectors with grounded metal housing.

In the case of non-shielded lines belongs to the same circuit, twist feeder and return cable.

9.3.9 General Measures of Radio Interference Suppression for Relays, Contactors, Switches, Chokes and Inductive Loads

If, in conjunction with electronic devices and components, inductive loads, such as chokes, contactors, relays are switched by contacts or semiconductors, appropriate interference suppression has to be provided for them:

- By arranging free-wheeling diodes in the case of d.c. operation
- In the case of a.c. operation, by arranging usual RC interference suppression elements depending on the contactor type, immediately at the inductance

Only the interference suppression element arranged immediately at the inductance does serve this purpose. Otherwise, the emitted noise level is too high which can affect the function of the electronic system and of the drive.

If possible, mechanical switches and contacts should only be realized as snap contacts. Contact pressure and contact material must be suited for the corresponding switching current.

Slow-action contacts should be replaced by snap switches or by solid-state switches, because slow-action contacts strongly bounce and are in an undefined switching status for a long time which emits electromagnetic waves in the case of inductive loads. These waves are an especially critical aspect in the case of manometric or temperature switches.

10 Operating Panel and Dust Cover

10.1 LED Panel

The LED panel is removable and composed of two areas: display and buttons. The display shows mode settings and operating state of the frequency converter. The buttons allow users to program the frequency converter.

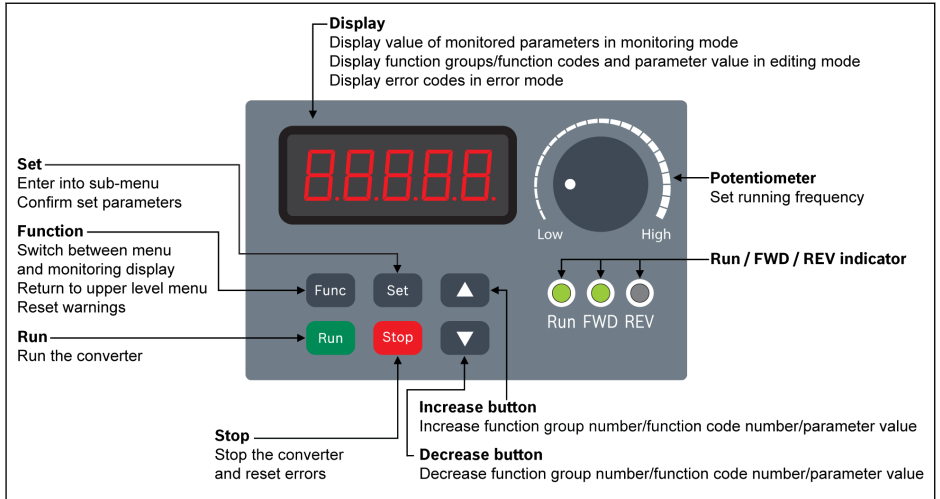

Fig. 10-1: LED panel

10.2 LED Display



Fig. 10-2: LED display

10.3 Dust Cover

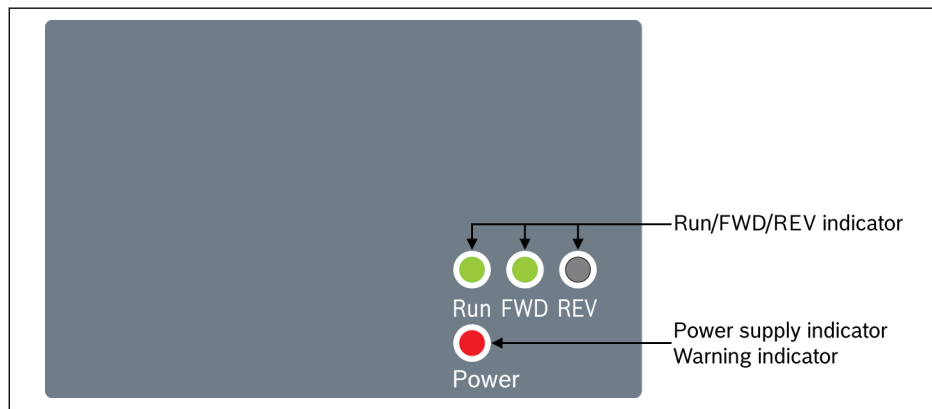

Fig. 10-3: Dust cover



Frequency Converter EFC x610 are available with **Dust Cover** instead of **LED Panel** on demand. To operate frequency converters with **Dust Cover**,

- Order an **LED Panel** additionally, and then set the frequency converter with [chapter 12.1.3 "Parameter Replication"](#) on page 80.

10.4 LED Indicator

Mode	Run	FWD	REV	Power [Ⓞ]
Power off	Off	Off	Off	Off
Ready	Off	Green / Off	Off / Green	Red
Run (FWD)	Green	Green	Off	Red
Run (REV)	Green	Off	Green	Red
Run pending	Blinks in green			
DC-braking at start	(Short green	Green / Off	Off / Green	Red
Direction change dead time	long dark)			
Deceleration stop phase	Blinks in green			
DC-braking at stop	(Short dark	Green / Off	Off / Green	Red
	long green)			
Warning with FWD	Green	Green	Off	Blinks in red (Short dark long red)
Warning with REV	Green	Off	Green	Blinks in red (Short dark long red)
Warning at stop	Off	Green / Off	Off / Green	Blinks in red (Short dark long red)
Error	Off	Green / Off	Off / Green	Blinks in red (Short red long dark)

Tab. 10-1: LED indicator status



- [Ⓞ]: Available on dust cover or when neither the LED panel nor the dust cover is installed.
- The frequency converter stops if FWD and REV commands are active at the same time.

10.5 Operating Descriptions

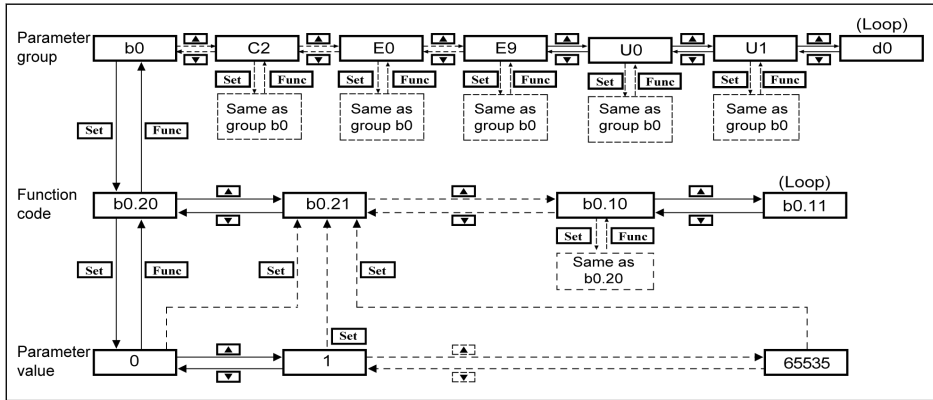

Fig. 10-4: Operating mode

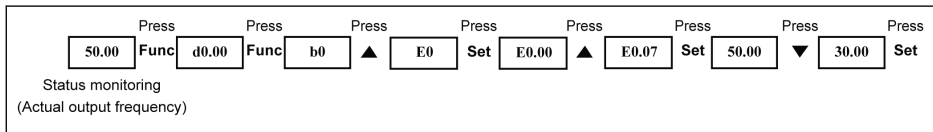

Fig. 10-5: Operating example

10.6 Fast Access to Parameters with Button Combinations

EFC x610 provides fast access to parameters within a parameter group with '<Func> + <▲>' or '<Func> + <▼>' combinations. This function is only valid for the tens digit of the function code index '□□.x□'.

- Pressing '<Func> + <▲>' once: '□□.x□' is changed to '□□.x+1□'
- Pressing '<Func> + <▼>' once: '□□.x□' is changed to '□□.x-1□'

Example: The frequency converter is now displaying 'E0.07' after setting with <Func>, <Set>, <▲> and <▼> buttons.

If 'E0.17' needs to be displayed based on 'E0.07', <▲> button has to be pressed for 10 times in the traditional way as described in the above figure. However, with button combination function, it is only necessary to press '<Func> + <▲>' buttons once.



- The parameter fast access function is only available when [b0.00] = 0, 1, or 2, unavailable with parameters in groups '-PF-' or '-EP-'
 - Press <Func> button and do not release it until <▲> or <▼> button has been pressed.
 - Press <▲> or <▼> button within 2 s if <Func> button is pressed.
 - If the index of parameters is not continuous in a specific parameter group, the adjacent parameter will be accessed. For example, the display of 'E0.01' should be changed to 'E0.11' with '<Func> + <▲>' button function. However, parameter E0.11 is unavailable in group E. While the adjacent parameter is E0.15. In this case, 'E0.15' is accessed and displayed.
-

10.7 Digit Shifting Function for Modification of Parameter Values

EFC x610 also provides the digit shifting function for modification of parameter values. To activate this function, press '<Func> + <▲>' or '<Func> + <▼>' once when the frequency converter is displaying a certain parameter value. After this action, the unit digit of the value blinks.

To select the digit for modification, press the following button combinations.

- Pressing '<Func> + <▲>' once: the blinking digit is shifted one digit leftwards.
- Pressing '<Func> + <▼>' once: the blinking digit is shifted one digit rightwards.

Example: [E0.07] = 35.40. The frequency is now displaying '35.40'.

If the value '35.40' needs to be modified to be 15.40, execute the following steps.

- Step 1: Pressing '<Func> + <▲>' or '<Func> + <▼>' once to activate the digit function. '35.40' is displayed with the unit digit '5' blinking.
- Step 2: Pressing '<Func> + <▲>' again to shift the blinking digit leftwards. '35.40' is displayed with tens digit '3' blinking.
- Step 3: Pressing <▼> twice to change the tens digit '3' to be '1'. '15.40' is displayed with tens digit '1' blinking.
- Step 4: Pressing <Set> to save the modified parameter value '15.40'. The display returns back to an upper menu level to show the next parameter with 'E0.08' displayed.



- The digit shifting function is only available for parameters with values and unavailable for parameter with options.
 - Press <Func> button and do not release it until <▲> or <▼> button has been pressed.
 - Press <▲> or <▼> button within 2 s if <Func> button is pressed.
 - Press <Func> button over 2 s without pressing any other button to cancel the uncompleted setting with button combinations.
-

11 Quick Start

11.1 Checklist before Quick Start

11.1.1 Step 1: Check application conditions

Rated ambient temperature	-10...45 °C
Derating / ambient temperature	1.5 % / 1 °C (45...55 °C)
Rated storage temperature	-20...60 °C
Rated altitude	≤ 1,000 m
Derating / altitude	1 % / 100 m (1,000...4,000 m)
Mounting mode (Wall mounting)	Wall mounting, DIN rail mounting

Tab. 11-1: Application conditions checklist

See also in [chapter 6.1.9 "Conditions"](#) on page 20.

11.1.2 Step 2: Check mounting conditions

Converter mounting direction	Vertical
Minimum top space	$d_{top} = 125 \text{ mm}$
Minimum bottom space	$d_{bot} = 125 \text{ mm}$
One converter is arranged above another	Air guide available is required in between
Mounting screws	4 x M6, no loose screws

Tab. 11-2: Mounting conditions checklist

See also in [chapter 7.1 "Installation Conditions"](#) on page 25.

11.1.3 Step 3: Check the wiring

Mains connection	Connect L1, L2, (L3) of converter to mains accordingly
Motor connection	Connect U, V, W of converter to motor accordingly
Grounding	Must be securely connected
Shielding	Must be securely connected
Power cables	Must observe chapter 8.2.1 "Power Cables" on page 32
Control terminals connection	Must be securely connected
Control cables	Must observe chapter 8.2.2 "Control Cables" on page 34
EMC	Must observe chapter 9 "Electromagnetic Compatibility (EMC)" on page 46
Switches	Must be switched off
Load	Must be disconnected

Tab. 11-3: Wiring checklist

11.2 Quick Start Parameters

Code	Name	Setting range	Default	Min.	Attri.
C0.05	Carrier frequency	1...15 kHz	ND: 4 HD: 6	1	Run
C1.05	Motor rated power	0.1...1,000.0 kW	DOM	0.1	Stop
C1.06	Motor rated voltage	0...480 V	DOM	1	Stop
C1.07	Motor rated current	0.01...655.00 A	DOM	0.01	Stop
C1.08	Motor rated frequency	5.00...400.00 Hz	50.00	0.01	Stop
C1.09	Motor rated speed	1...30,000 rpm	DOM	1	Stop
C2.00	V/f curve mode	0: Linear mode	0	-	Stop
		1: Square curve			
		2: User-defined curve			
E0.00	First frequency setting source	0...21	0	-	Stop
E0.01	First run command source	0...2	0	-	Stop
E0.07	Digital setting frequency	0.00...[E0.09] Hz	50.00	0.01	Run
E0.08	Maximum output frequency	50.00...400.00 Hz	50.00	0.01	Stop
E0.09	Output frequency high limit	[E0.10]...[E0.08] Hz	50.00	0.01	Run
E0.10	Output frequency low limit	0.00...[E0.09] Hz	0.00	0.01	Run
E0.17	Direction control	0: Forward / Reverse	0	-	Stop
		1: Forward only			
		2: Reverse only			
E0.25	Acceleration / deceleration curve mode	3: Swap default direction	0	-	Stop
		0: Linear mode			
		1: S-curve			
E0.26	Acceleration time	0.1...6,000.0 s	5.0	0.1	Run
E0.27	Deceleration time	0.1...6,000.0 s	5.0	0.1	Run
E0.35	Start mode	0: Start directly	0	-	Stop
		1: DC-braking before start			
		2: Start with speed capture			
E0.50	Stop mode	3: Automatic start / stop according to setting frequency	0	-	Stop
		0: Decelerating stop			
		1: Freewheeling stop			
E0.50	Stop mode	2: Freewheeling with stop command, decelerating with direction change	0	-	Stop
		0: Decelerating stop			
		1: Freewheeling stop			

Tab. 11-4: Quick start parameters

11.3 Control the Motor

WARNING

Ensure the enclosure is in place before the device is powered on. Wait for at least **5 minutes** after powering off to allow the DC capacitor being discharged, and do not remove the cover during this period!

Step	Operation	Description
1	Rotate the potentiometer counterclockwise (leftwards) to the greatest extent	Output frequency setting is 0.00
2	Press <Run> button	Control command active, 0.00 is displayed
	Rotate the potentiometer clockwise (rightwards) slowly till 5.00 is displayed	The motor starts to run
3	Observe the running status: If the motor runs in the correct direction If the motor runs steadily If there is any abnormal noise or problem	Recommended operation: Stop the motor immediately by switching off the power if any abnormality occurs Restart commissioning only after error causes have been removed
4	Rotate the potentiometer clockwise	The motor accelerates
5	Rotate the potentiometer counterclockwise	The motor decelerates
6	Press <Stop> button	Stop command activated, the motor stops
7	Check parameters without load	Settings according to actual applications
8	Check parameters with load	Settings according to actual applications

Tab. 11-5: Motor controlling procedure

- After powered on, EFC x610 will generate output if pressing down the **<Run>** button (or 'Control by terminals' is activated).
- By default, EFC x610 is set as:
 - The frequency converter is started or stopped by the operating panel.
 - The output frequency is set by the potentiometer on the operating panel.
- After powering on, please confirm:
 - The setting frequency is displayed (no error display).
 - The monitoring parameter is consistent with the actual situations.
- By default, **Output frequency** in run status and **Setting frequency** in stop status are displayed as the monitoring parameters, which can be changed to other parameters with parameters U1.00 and U1.10. The default settings are based on standard applications with standard motors.



For frequency converters with dust cover, it is recommended to install an LED panel to perform the above operations.

11.4 Motor Parameters Auto-Tuning

For SVC control and applications with higher requirement to control accuracy in V/f control, motor parameter auto-tuning is necessary. Two modes of auto-tuning are available, static auto-tuning and rotational auto-tuning. The former mode is mainly used for V/f control and the latter is used **ONLY** for SVC control.

Check and make sure the following points before auto-tuning:

- The motor is in standstill and not at high temperature.
- The power rating of the frequency converter is close to that of the motor.
- Set C1.05...C1.10 based on motor nameplate data. If the power factor data is unavailable on the nameplate, keep the default setting of C1.10.
- Set E0.08 according to motor parameters and actual application conditions.



Disconnect the load from the motor shaft for rotational auto-tuning.

Set auto-tuning mode and start motor parameter auto-tuning:

Set the following parameter according to the control mode of the frequency converter and the application situation.

Code	Name	Setting range	Default	Min.	Attri.
C1.01	Motor parameter tuning	0...2	0	-	Stop

- 0: Inactive. SVC control can still be used, but with lower performance.
- 1: Static auto-tuning. This mode is suggested to be used for V/f control. It can also be used for SVC control when the load cannot be disconnected.
- 2: Rotational auto-tuning (suggested to be used for SVC control)

Press the **<Run>** button on the operating panel to start auto-tuning. In the process of auto-tuning, a status code 'tUnE' will be displayed on the operating panel. When the auto-tuning process is complete, the status code disappears and the settings of the following parameters will be obtained automatically:

Static auto-tuning	Rotational auto-tuning	Parameters obtained by auto-tuning
√	√	C1.12: Motor rated slip frequency
√	√	C1.20: Motor no-load current
√	√	C1.21: Stator resistance
√	√	C1.22: Rotor resistance
√	√	C1.23: Leakage inductance
√	√	C1.24: Mutual inductance
√	√	C3.05: Current loop proportional gain
√	√	C3.06: Current loop integral time
-	√	C3.00: Speed loop proportional gain
-	√	C3.01: Speed loop integral time

Tab. 11-6: Parameters obtained by auto-tuning

11.5 Possible Errors during Quick Start and Respective Solutions

Errors	Solutions
Over current (SC, OC-1 or OC-2) occurs during acceleration	Increase the acceleration time
Over voltage (OE-3) occurs during deceleration	Increase the deceleration time
Over current (SC, OC-1 or OC-2) occurs immediately after pressing the <Run> button	Incorrect wiring. Check if U, V, W outputs of the main circuit are shorted or grounded
The motor runs in the direction opposite to expected	Change the sequence of any two phases of U, V and W
The motor vibrates and runs in uncertain directions after each starting	One phase of U, V and W is disconnected (output phase loss)

Tab. 11-7: Solutions for simple errors during commissioning

11.6 Restoring Parameters to Factory Defaults

If the frequency converter fails to run the motor due to incorrect parameter settings, a simple solution is to initialize the parameters to factory defaults. Setting [b0.10] = 1 will start initialization.

Please be sure that the parameter settings match with the motor and the field applications after factory defaults restore. Adjust the parameter settings after factory defaults restore if necessary.

Output frequency	Set by the potentiometer (E0.00)
Acceleration / deceleration time	Linear, Acc. for 5 s / Dec. for 5 s (E0.26, E0.27)
Protection mode in case of motor overload or overheat	Motor rated current (C1.07), Motor thermal protection time constant (C1.74), low speed derating frequency (C1.75), and zero speed load (C1.76)
Operating panel operation	<Run>, <Stop> buttons as command sources, potentiometer as frequency setting source
V/f curve mode	Linear

Tab. 11-8: Parameter settings by factory defaults

12 Functions and Parameters

12.1 Basic Settings

12.1.1 Parameter Group Access Control

This function is used to set parameters or read parameter settings fast. Five access modes are available with parameter b0.00.

Code	Name	Setting range	Default	Min.	Attri.
b0.00	Access authority setting	0...4	0	-	Run

For terminologies and abbreviations, see [chapter 19.3.1 "Terminology and Abbreviation in Parameter List" on page 253](#).

- 0: Basic parameters
ONLY parameters in group b0, d0, C0, E0, U0, U1 are visible.
- 1: Standard parameters
Parameters in group C1, C2, C3, E5, E8 are **ADDITIONALLY** visible.
- 2: Advanced parameters
Parameters in group E1, E2, E3, E4, E9 are **ADDITIONALLY** visible.
- 3: Start-up parameters
Parameters in group b0, d0 and [chapter 11.2 "Quick Start Parameters" on page 74](#) are visible.



[chapter 19.3.6 "Group d0: Monitoring Parameters" on page 274](#) are always visible.

- 4: Modified parameters
This option provides the possibility for users to view or modify the parameter settings which have been modified and different than default settings.
When [b0.00] = 4:
 - Parameters in group b0, group d0 and an additional group '-PF-' are visible.
 - Parameter settings can be modified directly once group '-PF-' has been accessed to.



- If a parameter in group '-PF-' is changed back to its default setting, that parameter is still visible in group '-PF-'. It is invisible after exit from and re-access to group '-PF-'.
- Parameters b0.10, b0.11, b0.20, b0.21, C1.01, C0.17, C0.53, E9.05...E9.07, E9.10...E9.15 are excluded for this function.
- Accessing to group '-PF-' if no parameter has been changed, the warning message 'noCP' will be displayed for 1.5 s, and then '-PF-' will be displayed again.

12.1.2 Parameter Initialization

This function is used to restore parameter settings to factory defaults when a frequency converter fails to drive the motor due to wrong parameter settings.

Be sure that the parameter settings match with the motor data and the actual applications after factory defaults restore. Adjust the parameter default settings if necessary.

Code	Name	Setting range	Default	Min.	Attri.
b0.10	Parameter initialization	0...2	0	–	Stop

- 0: Inactive

This parameter will be reset to '0: Inactive' automatically after parameter initialization.

- 1: Restore to default settings

All parameters are restored to factory default settings except for:

- C0.51 (Fan total running time)
- C1.00...C1.24 (Motor parameters)
- E9.05...E9.07, E9.10...E9.15 (Error records)
- d0.23 (Power stage running time)

- 2: Clear error record

Parameter E9.05... E9.07, E9.10...E9.15 (Error records) will be cleared.

12.1.3 Parameter Replication

This function is used for setting multiple frequency converters with the same settings via the operating panel.

With this function, users only need set parameters of one frequency converter (source converter), and then replicate its settings for all the other frequency converters (target converters).

Code	Name	Setting range	Default	Min.	Attri.
b0.11	Parameter replication	0...2	0	-	Stop

- 0: Inactive

This parameter will be reset to '0: Inactive' automatically after parameter replication.

- 1: Backup parameters to panel (from source converter to panel)

All parameter settings are copied from the source frequency converter to the operating panel **EXCEPT** that of

- Read-only parameters
- C0.51 (Fan total running time)
- E9.05...E9.07, E9.10...E9.15 (Error records)
- d0.23 (Power stage running time)

- 2: Restore parameters from panel (from panel to target converters)

All parameter settings are replicated from the operating panel to the target frequency converters **EXCEPT** that of

- Read-only parameters
- C0.51 (Fan total running time)
- E9.05...E9.07, E9.10...E9.15 (Error records)
- d0.23 (Power stage running time)



- Read-only parameters are marked with **Read** in parameter list, see [chapter 19.3.1 "Terminology and Abbreviation in Parameter List" on page 253](#)
- Any of other operations is inactive in parameter replication

12.1.4 Password Protection

Two types of passwords are available, user password and manufacturer password:

- User password: used to protect parameter settings from unauthorized or unintended changes.
- Manufacturer password: for service **ONLY**.

Code	Name	Setting range	Default	Min.	Attri.
b0.20	User password	0...65,535	0	1	Run
b0.21	Manufacturer password	0...65,535	0	1	Stop

Possible operations with passwords are as below:

- Set user password
The default setting of user password is '0' (inactive). Enter any integer number between 1 and 65,535.
- Change user password
Enter the existing user password first, and then modify the value with entering another integer number between 1 and 65,535.
- Clear user password
Enter the existing user password without entering and saving any number.



- Without entering or entering a wrong password, all parameters except for b0.00 'Access authority setting', can only be read, while parameter modification or replication is impossible.
- Contact with service if you forget the user password.
- User password protection does not affect frequency adjustment with <▲> and <▼> buttons in running status or frequency saving.

12.2 Input and Output Terminals Configuration

12.2.1 Digital Input Configuration

5 multi-function digital inputs are available with PNP and NPN wiring.

Code	Name	Setting range	Default	Min.	Attri.
E1.00	X1 input	0...41	0	1	Stop
E1.01	X2 input		0	1	Stop
E1.02	X3 input		0	1	Stop
E1.03	X4 input		0	1	Stop
E1.04	X5 input	0...47	0	1	Stop

- 0: No function assigned
- 1: Multi-speed control input 1
- 2: Multi-speed control input 2
- 3: Multi-speed control input 3
- 4: Multi-speed control input 4

16 multi-speeds are available by combination of 4 terminals, see [chapter "Adjust the setting frequency by multi-speed function" on page 103](#).

- 10: Acceleration / deceleration time 1 activation
- 11: Acceleration / deceleration time 2 activation
- 12: Acceleration / deceleration time 3 activation

Used to switch between 8 groups of acceleration / deceleration time, see [chapter 12.4.3 "Acceleration and Deceleration Configuration" on page 110](#).

- 15: Freewheeling stop activation

'Freewheeling stop activation' generates a stop command and forces the frequency converter to freewheel to stop regardless of the stopping mode configured by E0.50.

- 16: Stop DC-braking activation

This function is used when stopping mode is set with [E0.50] = '0: Decelerating stop'.

See [chapter 12.5.5 "Stop Behavior Setting" on page 125](#)

- 20: Frequency Up command
- 21: Frequency Down command
- 22: Up / Down command reset

Used to change the output frequency, see [chapter "Adjust the setting frequency by digital input Up / Down command" on page 101](#).

- 23: Torque / speed control switch

- 25: 3-wire running control
Used for the 3-wire control mode, see [chapter 12.6.3 "2-wire / 3-wire Control \(Forward / stop, reverse / stop\)"](#) on page 134.
- 26: Simple PLC stop
- 27: Simple PLC pause
Used for the simple PLC to stop and pause a PLC cycle, see [chapter 12.8.4 "Stop and Pause Simple PLC Control"](#) on page 148.
- 30: Second frequency setting source activation
Used for switching to the second frequency setting source, see [chapter "Frequency setting source switching"](#) on page 97.
- 31: Second run command source activation
Used for switching to the second run command source, see [chapter "Switch between first and second run command source"](#) on page 117.
- 32: Error signal N.O. contact input
- 33: Error signal N.C. contact input
Used for receive error signal from external sources, see [chapter 12.10.2 "Reaction to External Error Signals"](#) on page 166.
- 34: Error reset input
Used for error reset operation, see [chapter 13.5 "Error Handling"](#) on page 200.
- 35: Forward running (FWD)
- 36: Reverse running (REV)
Used for Run / Stop command control, see [chapter 12.5 "Run- / Stop- / Direction Command Source"](#) on page 116.
- 37: Forward jog
- 38: Reverse jog
See [chapter 12.6.2 "Jog Function"](#) on page 132.
- 39: Counter input
- 40: Counter reset
See [chapter 12.7.1 "Counter Function"](#) on page 139.
- 41: PID deactivation
See [chapter 12.9 "PID Control"](#) on page 151.
- 47: Pulse input mode activation (**ONLY** for X5 input)
See [chapter 12.2.2 " X5 Pulse Input Configuration"](#) on page 84.

12.2.2 X5 Pulse Input Configuration

X5 digital input can also be used to receive pulse signal with a 30...70 % duty ratio. This pulse input can be used in 3 purposes:

- Frequency setting source

See [chapter 12.4.2 "Select the Frequency Setting Source" on page 96](#).

- PID reference
- PID feedback

See [chapter 12.9.2 "Selecting the Reference and Feedback" on page 152](#).

To use 'X5 pulse input' as the frequency source, take following steps:

Step 1: Activate terminal 'X5 input' with pulse input function

Code	Name	Setting range	Default	Min.	Attri.
E1.04	X5 input	47: Pulse input mode activation	0	1	Stop

Step 2: Set the maximum input frequency and filter time

Code	Name	Setting range	Default	Min.	Attri.
E1.25	Pulse input maximum frequency	0.0...50.0 kHz	50.0	0.1	Run
E1.26	Pulse input filter time	0.000...2.000 s	0.100	0.001	Run

Step 3: Select pulse input curve

[E1.68]	bit 2	bit 1	bit 0	Curve for AI1	Curve for AI2	Curve for pulse input
0	0	0	0	1	1	1
1	0	0	1	2	1	1
2	0	1	0	1	2	1
3	0	1	1	2	2	1
4	1	0	0	1	1	2
5	1	0	1	2	1	2
6	1	1	0	1	2	2
7	1	1	1	2	2	2

Tab. 12-1: Curve configuration

[E1.70]...[E1.73] are used to define characteristics of curve 1:

Code	Name	Setting range	Default	Min.	Attri.
E1.68	Analog setting curve selection	0...7	0	–	Run
E1.70	Input curve 1 minimum	0.0%...[E1.72]	0.0	0.1	Run
E1.71	Input curve 1 minimum value	0.00...[E0.09] Hz	0.00	0.01	Run
E1.72	Input curve 1 maximum	[E1.70]...100.0%	100.0	0.1	Run
E1.73	Input curve 1 maximum value	0.00...[E0.09] Hz	50.00	0.01	Run

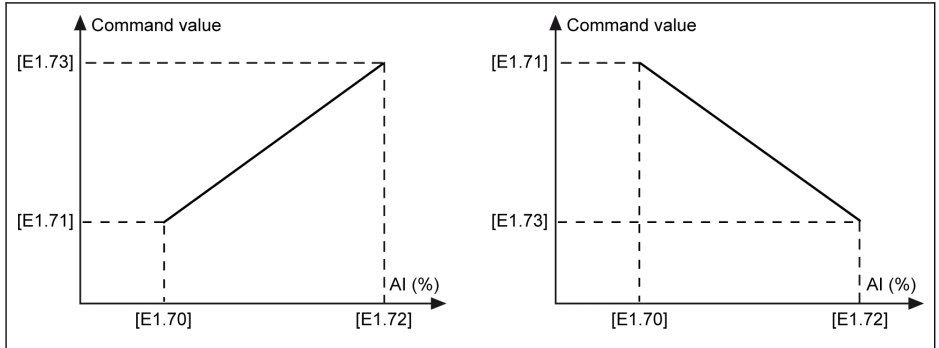

Fig. 12-1: Curve 1

[E1.75]...[E1.78] are used to define characteristics of curve 2:

Code	Name	Setting range	Default	Min.	Attri.
E1.68	Analog setting curve selection	0...7	0	-	Run
E1.75	Input curve 2 minimum	0.0%...[E1.77]	0.0	0.1	Run
E1.76	Input curve 2 minimum value	0.00...[E0.09] Hz	0.00	0.01	Run
E1.77	Input curve 2 maximum	[E1.75]...100.0%	100.0	0.1	Run
E1.78	Input curve 2 maximum value	0.00...[E0.09] Hz	50.00	0.01	Run

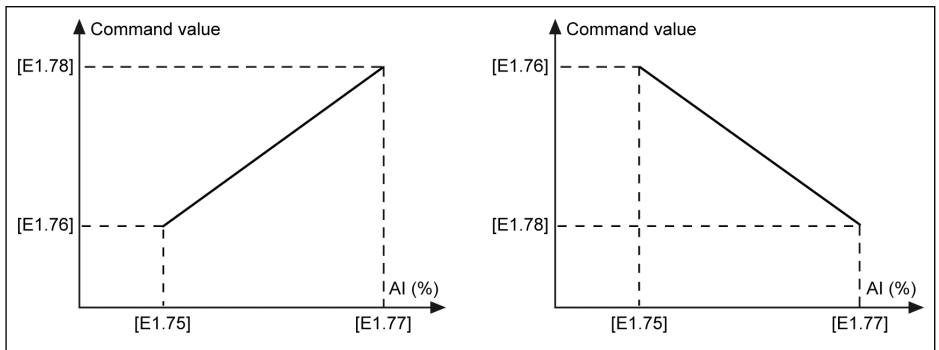

Fig. 12-2: Curve 2

12.2.3 Analog Input Configuration

Please read through the information on 'Wiring diagram' and 'Terminals' before configuration of 'Analog inputs AI1, AI2', see [chapter 8 "Frequency Converter Wiring" on page 31](#) and [chapter "Analog inputs" on page 41](#) respectively. To configure these two inputs, take the following steps:

Step 1: Select the input mode

Code	Name	Setting range	Default	Min.	Attri.
E1.35	AI1 input mode	0: 0...20 mA	2	-	Run
E1.40	AI2 input mode	1: 4...20 mA 2: 0...10 V 3: 0...5 V 4: 2...10 V	1	-	Run



When AI1 or AI2 is set to 4...20 mA, or 2...10 V, the broken wire detection for analog input can be configured, see [chapter "Analog Input Broken Wire Detection" on page 165](#).

Step 2: Set the channel gain and filter time

Code	Name	Setting range	Default	Min.	Attri.
E1.38	AI1 gain	0.00...10.00	1.00	0.01	Run
E1.43	AI2 gain	0.00...10.00	1.00	0.01	Run
E1.69	Analog channel filter time	0.000...2.000 s	0.100	0.001	Run

When AI1 or AI2 input is used as the reference frequency input channel, see [chapter "Adjust the setting frequency by analog input AI1, AI2" on page 100](#).

Step 3: Select input curve

AI1 and AI2 inputs can use both curve 1 and curve 2, see [chapter 12.2.2 "X5 Pulse Input Configuration" on page 84](#).

12.2.4 Digital Output Configuration

Please read through the information on 'Wiring diagram' and 'Terminals' before configuration of 'Digital output', see [chapter 8 "Frequency Converter Wiring" on page 31](#) and [chapter "Digital outputs" on page 42](#) respectively. To configure this output DO1, take the following steps:

Step 1: Select the output signal

Code	Name	Setting range	Default	Min.	Attri.
E2.01	DO1 output selection	0...20	0	–	Stop
E2.15	Relay1 output selection	0...20	1	–	Stop

- 0: Converter ready

After powering on, if no error occurs and there is no run command or output active indication, the frequency converter is ready for running.

- 1: Converter running

The output is active when the frequency converter is running and has frequency output (including 0.00 Hz).

- 2: Converter DC-braking

The output is active when the frequency converter is in Start- or Stop- DC braking, see [chapter "DC-braking before start" on page 121](#) and [chapter "DC-braking during deceleration to stop" on page 126](#).

- 3: Converter running at zero speed

The output is active when the frequency converter is running at zero speed.



There is no output for this selection during dead zone time of rotation direction change.

- 4: Speed arrival

See [chapter 12.7.2 "Frequency Arrival" on page 141](#).

- 5: Frequency level detection signal (FDT1)

6: Frequency level detection signal (FDT2)

See [chapter 12.7.3 "Frequency Level Detection" on page 142](#).

- 7: Simple PLC stage complete

8: Simple PLC cycle complete

See [chapter 12.8.4 "Stop and Pause Simple PLC Control" on page 148](#).

- 10: Converter undervoltage

The output is active when DC-bus voltage is lower than 230 VDC (1P 200 VAC models) / 430 VDC (3P 400 VAC models). The output will be inactive when DC-bus voltage resumes and becomes stable.

In addition, this digital output will be activated by any soft start error.

- 11: Converter overload pre-warning
See [chapter "Overload pre-warning" on page 161.](#)
- 12: Motor overload pre-warning
See [chapter "Motor overload pre-warning" on page 168.](#)
- 13: Converter stop by external error
See [chapter 12.10.2 "Reaction to External Error Signals" on page 166.](#)
- 14: Converter error
The output is active when an error occurs, inactive when the error is reset, see [chapter 13.4 "Error Code" on page 192.](#)
- 15: Converter OK
The output is inactive when the frequency converter is powered off or encounters error / warning during running. The output is active when the frequency converter is powered on but not running, or the frequency converter is running without error / warning.
- 16: Target counter value arrival
17: Middle counter value arrival
Used for the counter function, see [chapter 12.7.1 "Counter Function" on page 139.](#)
- 18: PID reference engineering value arrival
Used for PID function, see [chapter 12.9 "PID Control" on page 151.](#)
- 19: Pulse output mode (only available with DO1 output selection)
See '**Step 2: Use DO1 in pulse output mode**'.
- 20: Torque control mode
See [chapter "Torque control mode" on page 187.](#)

Step 2: Use DO1 in pulse output mode

Code	Name	Setting range	Default	Min.	Attri.
E2.01	DO1 output selection	19: Pulse output mode	0	-	Stop
E2.02	DO1 pulse output selection	0: Converter output frequency 1: Converter output voltage 2: Converter output current	0	-	Stop
E2.03	Pulse output maximum frequency	0.1...32.0 kHz	32.0	0.1	Run

12.2.5 Analog Output Configuration

Step 1: Set AO1 output mode

Code	Name	Setting range	Default	Min.	Attri.
E2.25	AO1 output mode	0: 0...10 V 1: 0...20 mA	0	-	Run

Step 2: Select AO1 output signal

Code	Name	Setting range	Default	Min.	Attri.
E2.26	AO1 output selection	0...11	0	-	Run
E2.40	Converter rated voltage for analog output	1P 200 VAC: 200...240 V 3P 400 VAC: 380...480 V	220 380	1	Stop

- 0: Running frequency
Represents the actual output frequency between 0.00...[E0.08] Hz.
- 1: Setting frequency
Represents the setting frequency between 0.00...[E0.08] Hz.
- 2: Output current
Represents the 0...2 x [rated current].
- 4: Output voltage
Represents 0...1.2 x [rated voltage], which is defined by parameter E2.40.
- 5: Output power, represents 0...1.2 x [rated power]
- 6: Analog input voltage, represents AI1 input value
- 7: Analog input current, represents AI2 input value
- 11: Motor temperature sensor power
Provides current source for motor temperature sensor, see [chapter "Motor thermal protection with temperature sensor" on page 169](#).

Step 3: Set AO1 filter time and output curve

Code	Name	Setting range	Default	Min.	Attri.
E2.27	AO1 gain setting	0.0...10.00	1.00	0.01	Run
E2.50	Output curve 1 minimum	0.0 %...[E2.52]	0.0	0.1	Run
E2.51	Output curve 1 minimum value	0.00...100.00 %	0.00	0.01	Run
E2.52	Output curve 1 maximum	[E2.50]...100.0 %	100.0	0.1	Run
E2.53	Output curve 1 maximum value	0.00...100.00 %	100.00	0.01	Run

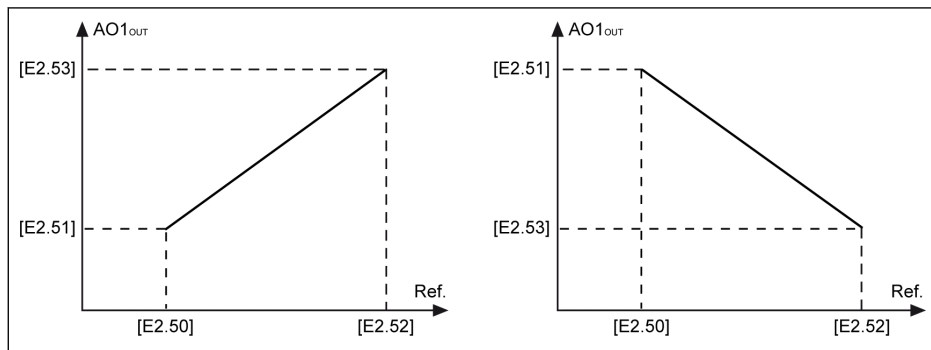

AO1_{out} AO1 output

Ref. Reference

Fig. 12-3: AO1 output curve

12.3 Power Stage Configuration

12.3.1 Set the Control Mode

This function is **ONLY** available with Frequency Converter EFC 5610. For Frequency Converter EFC 3610, **ONLY** 'V/f control' is available.

Code	Name	Setting range	Default	Min.	Attri.
C0.00	Control mode (EFC 5610 only)	0, 1	0	-	Stop

- 0: V/f control. This mode is active by default.
- 1: Sensorless vector control (SVC control)

Once this mode is active, parameters concerning **Motor parameterization** and **SVC control** also need to be set properly. See [chapter 12.11.1 "Motor Parameterization" on page 173](#) and [chapter 12.11.3 "EFC 5610 - SVC Control" on page 186](#) respectively.

12.3.2 Normal / Heavy Duty Setting

This function is used for switching the duty mode of a frequency converter according to the load type of the actual application. This function is **ONLY** available with Frequency Converter EFC 3610. For Frequency Converter EFC 5610, **ONLY** 'HD' is available.

Code	Name	Setting range	Default	Min.	Attri.
C0.01	Normal / Heavy duty setting (EFC 3610 only)	0, 1	1	-	Stop

- 0: ND (Normal duty)

Change the duty mode to 'Normal duty' by modifying the parameter setting from '1' to '0' according to the actual application.

Example:

A motor of 7.5 kW is used to drive a light load, e.g. a fan:

- Select a Frequency Converter EFC 3610 of 5.5 kW (5K50).
- Modify the duty mode of the frequency converter from 'Heavy duty' to 'Normal duty'.

- 1: HD (Heavy duty). This mode is set by default.

Example:

A motor of 7.5 kW is used to drive a heavy load, e.g. a compressor:

- Select a Frequency Converter EFC 3610 of 7.5 kW (7K50).



For overload capability and output current in ND and HD modes, see [chapter 6.1.2 "Output" on page 18](#).

12.3.3 Carrier Frequency Setting

Code	Name	Setting range	Default	Min.	Attri.
C0.05	Carrier frequency	1...15 kHz	ND: 4 HD: 6	1	Run
C0.06	Carrier frequency automatic adjustment	0: Inactive 1: Active	0	-	Stop

The carrier frequency is 4 kHz for ND models, 6 kHz for HD models by default. With setting parameter C0.05, the carrier frequency can be modified to an integer value of 1...15 kHz. The relationship between the carrier frequency, heat dissipation, noise level, and leakage current and interference is shown as below:

	Heat dissipation	Noise	Leakage current and interference
Higher carrier frequency	Higher	Lower	Higher
Lower carrier frequency	Lower	Higher	Lower

Tab. 12-2: Influence of carrier frequency

For derating figures related to carrier frequency, see [chapter 6.2.2 "Derating of Electric Data"](#) on page 22.



To achieve optimized performance, the carrier frequency setting should follow the equation: $[C0.05] \geq 10 \times [E0.08]$.

With $[C0.06] = 1$, the carrier frequency can also be changed automatically to keep the power module temperature within the normal range.

12.3.4 Fan Control

This function is used to set the running mode of the fan for the heat sink.



The fan for the capacitor is switched on and running all the time once the frequency converter is powered on.

Code	Name	Setting range	Default	Min.	Attri.
C0.50	Fan control	0: Automatically controlled 1: Always on	0	-	Run

- 0: Automatically controlled

The fan for the heat sink is by default switched on / off automatically according to the temperature of the heat sink. In this mode, the noise level of the frequency converter can be reduced.

- 1: Always on

The fan for the heat sink is switched on and running all the time once the frequency converter is powered on. In this mode, a better cooling performance of the frequency converter can be achieved.

12.3.5 Fan Maintenance Reminder

This function is used to remind users maintaining the cooling fan in time. The maintenance time can be set according to the actual application conditions.

Code	Name	Setting range	Default	Min.	Attri.
C0.51	Fan total running time	0...65,535 h	0	1	Read
C0.52	Fan maintenance time	0...65,535 h	0	1	Stop
C0.53	Fan total running time reset	0: Inactive 1: Active	0	-	Run

To use this function, take the following steps:

Step 1: Set the maintenance time of the fan properly

Set parameter C0.52 'Fan maintenance time' according to the actual application conditions after 'Quick Start' of the frequency converter.

Step 2: Observe the fan lifetime status at warning

When a warning code 'FLE' (Fan maintenance period expired) is displayed on the operating panel, [C0.51] 'Fan total running time' is higher than [C0.52] 'Fan maintenance time'.

- Pause the display of the warning code 'FLE' by pressing the <Func> button.
- Perform fan maintenance or replacement.

Step 3: Reset the fan lifetime counter after fan maintenance or replacement

- Set parameter C0.53 'Fan total running time reset' to '1: Active'
 After the execution, [C0.53] and [C0.51] will be reset to '0' automatically. By now, the warning code 'FLE' is cleared completely.
- Adjust the value of C0.52 'Fan maintenance time' if necessary

12.4 Basic Frequency Setting Sources

12.4.1 Function Description

Four means of frequency setting sources are available with priority (0, 1, 2, 3) as shown in the figure below.

Only frequency setting source of the fourth priority '3: Basic frequency setting sources' is introduced in this chapter. Other frequency setting sources of '0: PID control', '1: Simple PLC' and '2: Jog function' will be introduced later in separate chapters.

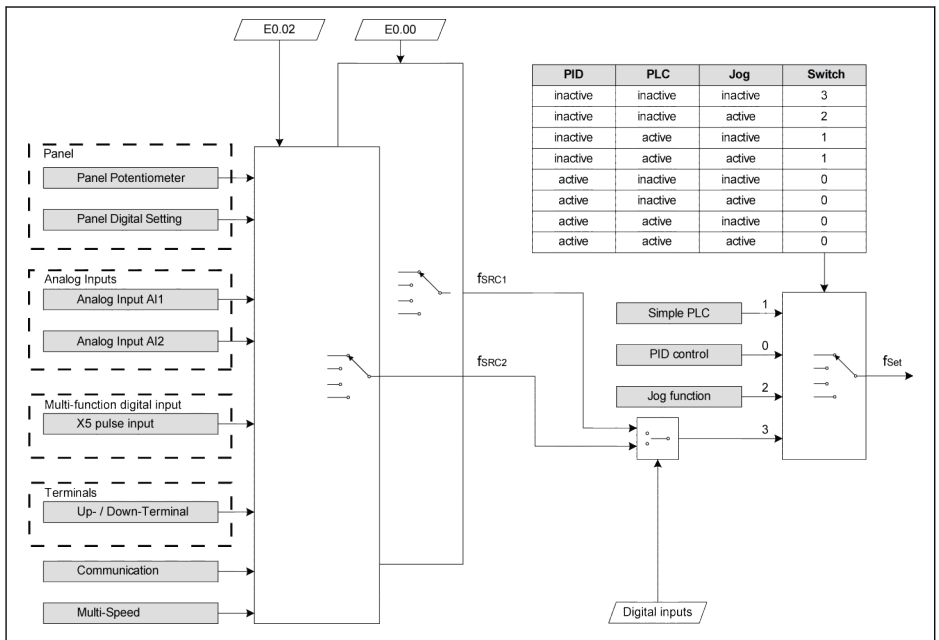

f_{SRC1} First frequency setting source
f_{SRC2} Second frequency setting source
0 First priority (PID control)
1 Second priority (Simple PLC)

2 Third priority (Jog function)
3 Fourth priority (Basic frequency setting sources)
f_{Set} Setting frequency

Fig. 12-4: Frequency setting sources



The frequency setting source switching and combination cannot be active at the same time.

12.4.2 Select the Frequency Setting Source

General setting

Different frequency setting sources can be selected by setting parameter E0.00 'First frequency setting source' or E0.02 'Second frequency setting source'.

Code	Name	Setting range	Default	Min.	Attri.
E0.00	First frequency setting source	0...21	0	–	Stop
E0.02	Second frequency setting source	0...21	2	–	Stop

- 0: Panel potentiometer

The setting frequency is set by adjusting the potentiometer on the operating panel.

- 1: Panel button setting

The setting frequency is set by parameter E0.07 'Digital setting frequency'. Pressing <▼> and <▲> buttons on the operating panel will decrease and increase the output frequency respectively when the frequency converter is running.

- 2: AI1 analog input

The setting frequency is set by AI1 input.

- 3: AI2 analog input

The setting frequency is set by AI2 input.

- 10: X5 pulse input

The setting frequency is set by pulse input via X5 input.

- 11: Digital input Up / Down command

The setting frequency is set by command of Up / Down / Reset via X1...X5 inputs.

- 20: Communication

The setting frequency is set by engineering software, PLC or other external device via Modbus protocol.

- 21: Multi-speed settings

The setting frequency is set by multi-speed settings.

Frequency setting source switching

When [E0.04] = 0, 'Frequency setting source combination' is inactive. The setting frequency can be switched between the first and second frequency setting source by X1...X5 digital input.

If status of the selected digital input is changed when frequency converter is running, the frequency setting source will be switched instantly and the frequency converter will accelerate / decelerate according to the actual setting frequency of respective frequency setting source.

The active / inactive of the selected digital input is triggered by voltage level, instead of the edge.

Code	Name	Setting range	Default	Min.	Attri.
E1.00	X1 input	30: Second frequency setting source activation	0	1	Stop
E1.01	X2 input		0	1	Stop
E1.02	X3 input		0	1	Stop
E1.03	X4 input		0	1	Stop
E1.04	X5 input		0	1	Stop

To use the frequency setting source switching function, take the following steps:

Step 1: Check and be sure that [E0.04] = '0: No combination'

Step 2: Select the second frequency setting source by setting parameter E0.02

Step 3: Configure the setting frequency for the selected frequency setting source

Step 4: Select a digital input terminal from X1...X5, and set its function to '30: Second frequency setting source activation'

Example:

[E0.00] = '0: Panel potentiometer', the setting frequency of the first frequency setting source is 30.00 Hz.

[E0.02] = '3: AI2 analog input', the setting frequency of the second frequency setting source is 50.00 Hz.

Set [E1.00] = 30, X1 is used to switch the setting frequency between the first and the second frequency sources.

- When X1 input is inactive, the actual setting frequency is 30.00 Hz set by panel potentiometer.
- When X1 input is active, the actual setting frequency is 50.00 Hz set by AI2 analog input and the converter accelerates from 30.00 Hz to 50.00 Hz.

Frequency setting sources combination

It is possible to combine the two frequency setting sources for complicated applications.

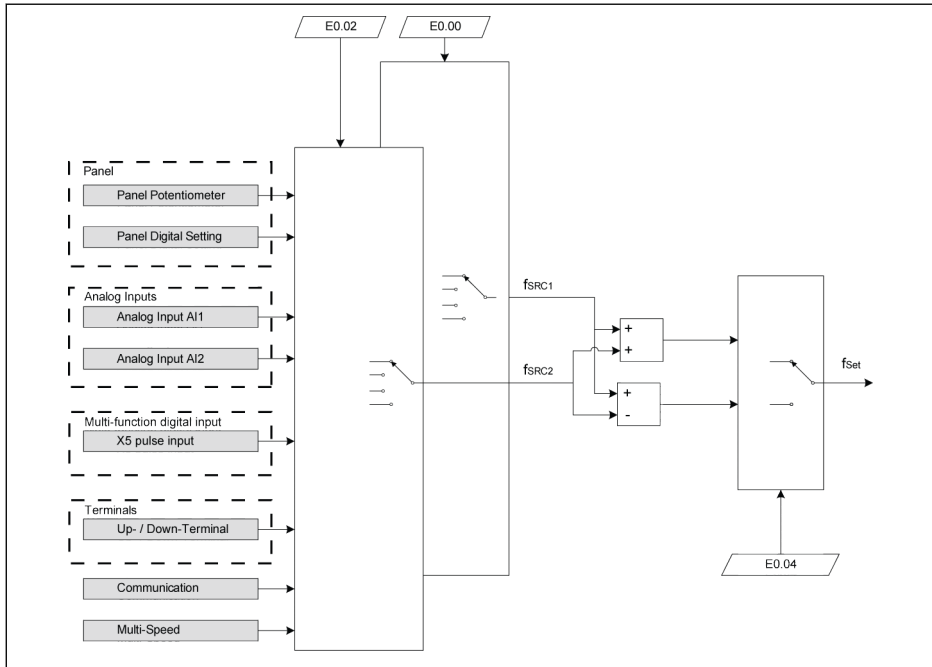

f_{SRC1} First frequency setting source

f_{Set} Setting frequency

f_{SRC2} Second frequency setting source

Fig. 12-5: Combination of frequency sources

Code	Name	Setting range	Default	Min.	Attri.
E0.04	Frequency setting source combination	0...2	0	-	Stop

- 0: No combination

By default, actual setting frequency is set by 'First frequency setting source'. 'Second frequency setting source' can be activated by one of X1...X5 digital inputs, see [chapter "Frequency setting source switching" on page 97](#).

- 1: First frequency setting + Second frequency setting

The actual setting frequency is the result of the addition operation of the first and second frequency setting sources.

- 2: First frequency setting - Second frequency setting

The actual setting frequency is the result of the subtraction operation of the first and second frequency setting sources.

To use the frequency setting source combination function, take the following steps:

Step 1: Be sure that [E1.00] ≠ '30: Second frequency setting source activation' to deactivate the frequency setting source switching function

Step 2: Set parameter E0.00 and E0.02 to select the first and second frequency setting sources

Step 3: Set parameter [E0.04] = 1 or 2 according to the actual application



The result of the combination is always limited within the range of 0.00...[E0.09] Hz.

Adjust the setting frequency by panel potentiometer

By default, the first frequency setting source is from the potentiometer on the operating panel. To adjust the output frequency, follow the instructions below:

- Rotate the potentiometer counterclockwise (leftwards)
The output frequency decreases, and the motor decelerates.
- Rotate the potentiometer clockwise (rightwards)
The output frequency increases, and the motor accelerates.

Adjust the setting frequency by panel button

The setting frequency of the first and second frequency setting sources can be adjusted by pressing the <▲> / <▼> button on the operating panel.

Code	Name	Setting range	Default	Min.	Attri.
E0.00	First frequency setting source	1: Panel button setting	0	-	Stop
E0.02	Second frequency setting source		2	-	Stop
E0.07	Digital setting frequency	0.00...[E0.09] Hz	50.00	0.01	Run

Adjust the setting frequency by analog input AI1, AI2

When analog input AI1, AI2 is used as the frequency setting source, the relationship between AI1, AI2 and the setting frequency is shown as the figure below:

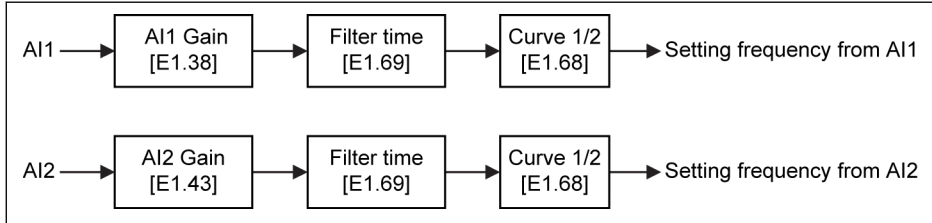

Fig. 12-6: AI1, AI2 and setting frequency



To set analog input AI1, AI2 properly, see [chapter 12.2.3 "Analog Input Configuration"](#) on page 86.

Adjust the setting frequency by X5 pulse input

When X5 pulse input is used as the frequency setting source, the setting frequency can be changed by changing the pulse frequency.

By default, 'Pulse input maximum frequency' [E1.25] = 50.0 kHz, which can be adjusted according to the actual application.



Fig. 12-7: X5 pulse input and setting frequency



To set X5 pulse input properly, see [chapter 12.2.2 "X5 Pulse Input Configuration"](#) on page 84.

Adjust the setting frequency by digital input Up / Down command

The setting frequency can also be adjusted with command of Up / Down / Reset, by setting the status of digital inputs X1...X5.

The setting frequency will increase with Up command active, decrease with Down command active, reset to '0' with Reset command active.

To use this function, take the following steps:

Step 1: Set the frequency setting source

Set either the first or the second frequency setting source to '11: Digital input Up / Down command'.

Code	Name	Setting range	Default	Min.	Attri.
E0.00	First frequency setting source	11: Digital input Up / Down command	0	-	Stop
E0.02	Second frequency setting source		2	-	Stop

Step 2: Select any 3 digital inputs and define functions accordingly

Code	Name	Setting range	Default	Min.	Attri.
E1.00	X1 input	20: Frequency Up command 21: Frequency Down command 22: Up / Down command reset	0	1	Stop
E1.01	X2 input		0	1	Stop
E1.02	X3 input		0	1	Stop
E1.03	X4 input		0	1	Stop
E1.04	X5 input		0	1	Stop

Step 3: Set the change rate and initial frequency for Up / Down operation

Code	Name	Setting range	Default	Min.	Attri.
E1.16	Up / Down terminal change rate	0.10...100.00 Hz/s	1.00	0.01	Run
E1.17	Up / Down terminal initial frequency	0.00...[E0.09] Hz	0.00	0.01	Run

Example: [E1.00] = 20, [E1.01] = 21, [E1.02] = 22

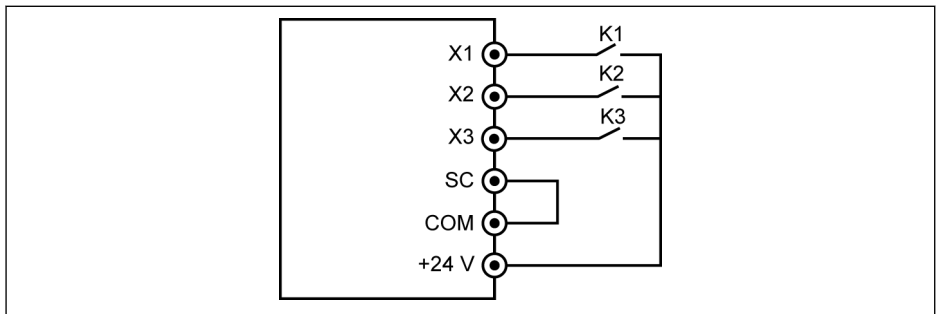

Fig. 12-8: External control terminals

Connect switch K1 to X1, and set [E1.00] = '20: Frequency Up command'.

Connect switch K2 to X2, and set [E1.01] = '21: Frequency Down command'.
 Connect switch K3 to X3, and set [E1.02] = '22: Up / Down command reset'.

K1	K2	K3	Response of setting frequency
Closed / Open	Closed / Open	Closed	Is reset to 0.00 Hz
Closed	Open	Open	Increases from [E1.17] with the change rate defined by [E1.16]
Open	Closed	Open	Decreases from [E1.17] with the change rate defined by [E1.16]
Open	Open	Open	No change
Closed	Closed	Open	No change

Tab. 12-3: K1, K2, K3 settings



Up / Down / Reset command is only active when the frequency converter is running. Whether the setting frequency modified by Up / Down terminals will be saved or not after power off depends on [E0.06], see [chapter 12.4.5 "Frequency Setting Saving" on page 115](#).

Adjust the setting frequency by multi-speed function

Multi-speed function offers flexible, switchable 16 independent stages of setting frequency. The rotation direction of each stage depends on both the 'Stage action' and the 'Run command source', see the table below:

Frequency source	Run command source	Rotation direction	Acc. / Dec. time
Multi-speed	Operating panel	[E3.60], [E3.62], [E3.64], [E3.66]	[E0.26] / [E0.27]
		[E3.68], [E3.70], [E3.72], [E3.74]	[E3.10] / [E3.11]
		[E3.76], [E3.78], [E3.80], [E3.82]	[E3.12] / [E3.13]
		[E3.84], [E3.86], [E3.88], [E3.90]	[E3.14] / [E3.15]
	External terminals	8 or less stages: 2-wire control	[E3.16] / [E3.17]
		9 or more stages: parameters	[E3.18] / [E3.19]
	Communication	Set by communication	[E3.20] / [E3.21] [E3.22] / [E3.23]

Tab. 12-4: Setting frequency and multi-speed settings

To configure the multi-speed settings, take the following steps:

Step 1: Activate multi-speed function

Code	Name	Setting range	Default	Min.	Attri.
E0.00	First frequency setting source	21: Multi-speed settings	0	-	Stop
E0.02	Second frequency setting source		2	-	Stop

Step 2: Select any 3 digital inputs and define functions accordingly

Assign functions to X1...X5 input properly when 'Acceleration / deceleration time activation' and '2-wire / 3-wire running control' are also necessary defined via digital inputs.

Code	Name	Setting range	Default	Min.	Attri.
E1.00	X1 input	1: Multi-speed control input 1 2: Multi-speed control input 2 3: Multi-speed control input 3 4: Multi-speed control input 4	0	1	Stop
E1.01	X2 input		0	1	Stop
E1.02	X3 input		0	1	Stop
E1.03	X4 input		0	1	Stop
E1.04	X5 input		0	1	Stop

Step 3: Configure the setting frequency for each stage

If the setting frequency of next stage is lower than that of the current stage, it will decelerate to the next stage with the deceleration time of the current stage; if the setting frequency of next stage is higher than that of the current stage, it will accelerate to the next stage with the acceleration time of next stage.

Code	Name	Setting range	Default	Min.	Attri.
E0.07	Digital setting frequency	0.00...[E0.09] Hz	50.00	0.01	Run
E3.40	Multi-speed frequency 1	0.00...[E0.09] Hz	0.00	0.01	Run
E3.41	Multi-speed frequency 2	0.00...[E0.09] Hz	0.00	0.01	Run
E3.42	Multi-speed frequency 3	0.00...[E0.09] Hz	0.00	0.01	Run
E3.43	Multi-speed frequency 4	0.00...[E0.09] Hz	0.00	0.01	Run
E3.44	Multi-speed frequency 5	0.00...[E0.09] Hz	0.00	0.01	Run
E3.45	Multi-speed frequency 6	0.00...[E0.09] Hz	0.00	0.01	Run
E3.46	Multi-speed frequency 7	0.00...[E0.09] Hz	0.00	0.01	Run
E3.47	Multi-speed frequency 8	0.00...[E0.09] Hz	0.00	0.01	Run
E3.48	Multi-speed frequency 9	0.00...[E0.09] Hz	0.00	0.01	Run
E3.49	Multi-speed frequency 10	0.00...[E0.09] Hz	0.00	0.01	Run
E3.50	Multi-speed frequency 11	0.00...[E0.09] Hz	0.00	0.01	Run
E3.51	Multi-speed frequency 12	0.00...[E0.09] Hz	0.00	0.01	Run
E3.52	Multi-speed frequency 13	0.00...[E0.09] Hz	0.00	0.01	Run
E3.53	Multi-speed frequency 14	0.00...[E0.09] Hz	0.00	0.01	Run
E3.54	Multi-speed frequency 15	0.00...[E0.09] Hz	0.00	0.01	Run

Step 4: Set the acceleration time / deceleration time, rotation direction for each stage

Code	Name	Setting range	Default	Min.	Attri.
E3.60	Stage 0 action		011	-	Stop
E3.62	Stage 1 action	011, 012, 013, 014, 015, 016, 017, 018, 021, 022, 023, 024, 025, 026,	011	-	Stop
E3.64	Stage 2 action	027, 028, 031, 032, 033, 034, 035,	011	-	Stop
E3.66	Stage 3 action	036, 037, 038, 041, 042, 043, 044,	011	-	Stop
E3.68	Stage 4 action	045, 046, 047, 048, 051, 052, 053,	011	-	Stop
E3.70	Stage 5 action	054, 055, 056, 057, 058, 061, 062,	011	-	Stop
E3.72	Stage 6 action	063, 064, 065, 066, 067, 068, 071,	011	-	Stop
E3.74	Stage 7 action	072, 073, 074, 075, 076, 077, 078,	011	-	Stop
E3.76	Stage 8 action	081, 082, 083, 084, 085, 086, 087,	011	-	Stop
E3.78	Stage 9 action	088, 111, 112, 113, 114, 115, 116,	011	-	Stop
E3.80	Stage 10 action	117, 118, 121, 122, 123, 124, 125,	011	-	Stop
E3.82	Stage 11 action	126, 127, 128, 131, 132, 133, 134,	011	-	Stop
E3.84	Stage 12 action	135, 136, 137, 138, 141, 142, 143,	011	-	Stop
E3.86	Stage 13 action	144, 145, 146, 147, 148, 151, 152,	011	-	Stop
E3.88	Stage 14 action	153, 154, 155, 156, 157, 158, 161,	011	-	Stop
E3.90	Stage 15 action	162, 163, 164, 165, 166, 167, 168,	011	-	Stop
		171, 172, 173, 174, 175, 176, 177,			
		178, 181, 182, 183, 184, 185, 186,			
		187, 188	011	-	Stop
			011	-	Stop

Code	Name	Setting range	Default	Min.	Attri.
E0.26	Acceleration time	0.1...6000.0 s	5.0	0.1	Run
E0.27	Deceleration time	0.1...6000.0 s	5.0	0.1	Run
E3.10	Acceleration time 2	0.1...6000.0 s	10.0	0.1	Run
E3.11	Deceleration time 2	0.1...6000.0 s	10.0	0.1	Run
E3.12	Acceleration time 3	0.1...6000.0 s	10.0	0.1	Run
E3.13	Deceleration time 3	0.1...6000.0 s	10.0	0.1	Run
E3.14	Acceleration time 4	0.1...6000.0 s	10.0	0.1	Run
E3.15	Deceleration time 4	0.1...6000.0 s	10.0	0.1	Run
E3.16	Acceleration time 5	0.1...6000.0 s	10.0	0.1	Run
E3.17	Deceleration time 5	0.1...6000.0 s	10.0	0.1	Run
E3.18	Acceleration time 6	0.1...6,000.0 s	10.0	0.1	Run
E3.19	Deceleration time 6	0.1...6,000.0 s	10.0	0.1	Run
E3.20	Acceleration time 7	0.1...6,000.0 s	10.0	0.1	Run
E3.21	Deceleration time 7	0.1...6,000.0 s	10.0	0.1	Run
E3.22	Acceleration time 8	0.1...6,000.0 s	10.0	0.1	Run
E3.23	Deceleration time 8	0.1...6,000.0 s	10.0	0.1	Run

The digit definition for each stage action is as the figure below:

Digit:	Hundreds	Tens	Unit
Example:	0	1	1
Rotation direction			
Forward (FWD).....	= 0		
Reverse (REV).....	= 1		
Acceleration time			
[E2.26] Acceleration time	= 1		
[E3.10] Acceleration time 2.....	= 2		
[E3.12] Acceleration time 3.....	= 3		
[E3.14] Acceleration time 4.....	= 4		
[E3.16] Acceleration time 5.....	= 5		
[E3.18] Acceleration time 6.....	= 6		
[E3.20] Acceleration time 7.....	= 7		
[E3.22] Acceleration time 8.....	= 8		
Deceleration time			
[E0.27] Deceleration time.....	= 1		
[E3.11] Deceleration time 2.....	= 2		
[E3.13] Deceleration time 3.....	= 3		
[E3.15] Deceleration time 4.....	= 4		
[E3.17] Deceleration time 5.....	= 5		
[E3.19] Deceleration time 6.....	= 6		
[E3.21] Deceleration time 7.....	= 7		
[E3.23] Deceleration time 8.....	= 8		

Fig. 12-9: Bit definition of rotation direction, acceleration and deceleration time

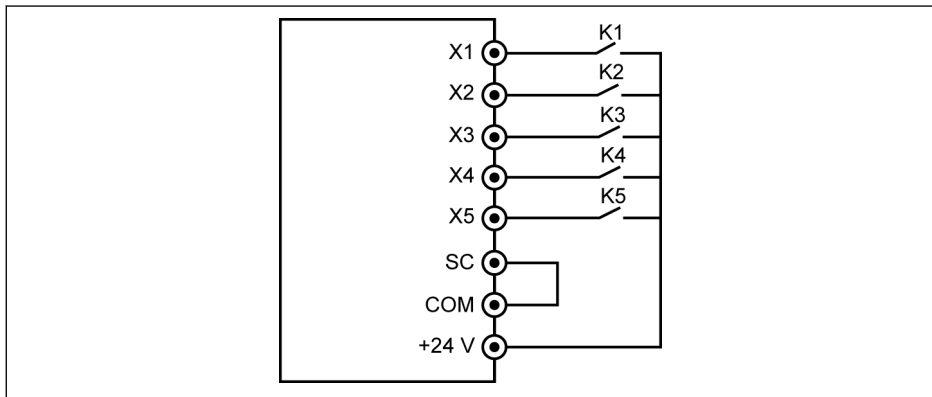

Fig. 12-10: Multi-speed control via digital inputs

Case 1: 8 or less stages

Set [E1.15] = 0 or 1 first.

Connect switch K1 to X1, and set [E1.00] = '1: Multi-speed control input 1'.

Connect switch K2 to X2, and set [E1.01] = '2: Multi-speed control input 2'.

Connect switch K3 to X3, and set [E1.02] = '3: Multi-speed control input 3'.

Connect switch K4 to X4, and set [E1.03] = '35: Forward running (FWD)'.

Connect switch K5 to X5, and set [E1.04] = '36: Reverse running (REV)'.

K5	K4	K3	K2	K1	Setting frequency	Acc. / Dec. time
See chapter "2-wire control mode 1" on page 134 and chapter "2-wire control mode 2 (Forward / reverse, run / stop)" on page 135		Open	Open	Open	[E0.07]	[E0.26] / [E0.27]
		Open	Open	Closed	[E3.40]	[E3.10] / [E3.11]
		Open	Closed	Open	[E3.41]	[E3.12] / [E3.13]
		Open	Closed	Closed	[E3.42]	[E3.14] / [E3.15]
		Closed	Open	Open	[E3.43]	[E3.16] / [E3.17]
		Closed	Open	Closed	[E3.44]	[E3.18] / [E3.19]
		Closed	Closed	Open	[E3.45]	[E3.20] / [E3.21]
		Closed	Closed	Closed	[E3.46]	[E3.22] / [E3.23]
		Open	Open	Open	[E3.47]	[E0.26] / [E0.27]
		Open	Open	Closed	[E3.48]	[E3.10] / [E3.11]
		Open	Closed	Open	[E3.49]	[E3.12] / [E3.13]
		Open	Closed	Closed	[E3.50]	[E3.14] / [E3.15]
		Closed	Open	Open	[E3.51]	[E3.16] / [E3.17]
		Closed	Open	Closed	[E3.52]	[E3.18] / [E3.19]
	Closed	Closed	Open	[E3.53]	[E3.20] / [E3.21]	
	Closed	Closed	Closed	[E3.54]	[E3.22] / [E3.23]	

Tab. 12-5: Multi-speed settings for 8 or less stages

Case 2: 9 or more stages

Set [E1.15] = 4 first.

Connect switch K1 to X1, and set [E1.00] = '1: Multi-speed control input 1'.

Connect switch K2 to X2, and set [E1.01] = '2: Multi-speed control input 2'.

Connect switch K3 to X3, and set [E1.02] = '3: Multi-speed control input 3'.

Connect switch K4 to X4, and set [E1.03] = '4: Multi-speed control input 4'.

Connect switch K5 to X5, and set [E1.04] = '35: Forward running (FWD)'.

K4	K3	K2	K1	Setting frequency	Acc. / Dec. time
Open	Open	Open	Open	[E0.07]	[E0.26] / [E0.27]
Open	Open	Open	Closed	[E3.40]	[E3.10] / [E3.11]
Open	Open	Closed	Open	[E3.41]	[E3.12] / [E3.13]
Open	Open	Closed	Closed	[E3.42]	[E3.14] / [E3.15]
Open	Closed	Open	Open	[E3.43]	[E3.16] / [E3.17]
Open	Closed	Open	Closed	[E3.44]	[E3.18] / [E3.19]
Open	Closed	Closed	Open	[E3.45]	[E3.20] / [E3.21]
Open	Closed	Closed	Closed	[E3.46]	[E3.22] / [E3.23]

K4	K3	K2	K1	Setting frequency	Acc. / Dec. time
Closed	Open	Open	Open	[E3.47]	[E0.26] / [E0.27]
Closed	Open	Open	Closed	[E3.48]	[E3.10] / [E3.11]
Closed	Open	Closed	Open	[E3.49]	[E3.12] / [E3.13]
Closed	Open	Closed	Closed	[E3.50]	[E3.14] / [E3.15]
Closed	Closed	Open	Open	[E3.51]	[E3.16] / [E3.17]
Closed	Closed	Open	Closed	[E3.52]	[E3.18] / [E3.19]
Closed	Closed	Closed	Open	[E3.53]	[E3.20] / [E3.21]
Closed	Closed	Closed	Closed	[E3.54]	[E3.22] / [E3.23]

Tab. 12-6: Multi-speed settings for 9 or more stages

K5	Status
Inactive	Stop
Active	Run

Tab. 12-7: Run / Stop control via K5



Direction is controlled by parameters, see [fig. 12-9 "Bit definition of rotation direction, acceleration and deceleration time"](#) on page 106.

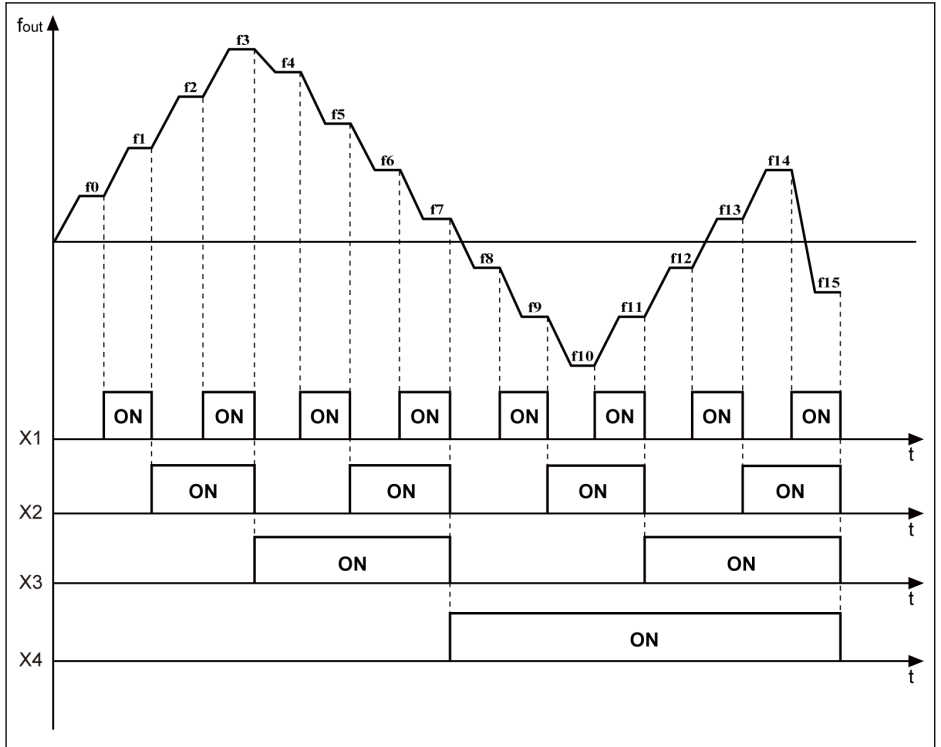

f_{out} Output frequency
 t Time

ON Digital input switched on

Fig. 12-11: Multi-speed stage transition

12.4.3 Acceleration and Deceleration Configuration

Acceleration and deceleration time configuration

Acceleration / deceleration time setting is the time for frequency increase from 0.00 Hz to [E0.08] 'Maximum output frequency' / the time for frequency decrease from [E0.08] to 0.00 Hz respectively.

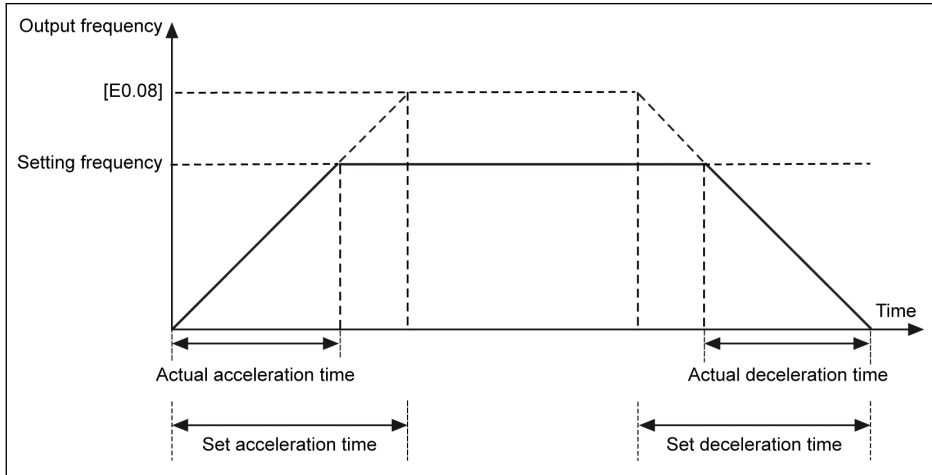

Fig. 12-12: Acceleration and deceleration time

8 groups of acceleration / deceleration time are available, which can be selected by setting X1...X5 digital inputs.

Code	Name	Setting range	Default	Min.	Attri.
E0.26	Acceleration time	0.1...6,000.0 s	5.0	0.1	Run
E0.27	Deceleration time	0.1...6,000.0 s	5.0	0.1	Run
E3.10	Acceleration time 2	0.1...6,000.0 s	10.0	0.1	Run
E3.11	Deceleration time 2	0.1...6,000.0 s	10.0	0.1	Run
E3.12	Acceleration time 3	0.1...6,000.0 s	10.0	0.1	Run
E3.13	Deceleration time 3	0.1...6,000.0 s	10.0	0.1	Run
E3.14	Acceleration time 4	0.1...6,000.0 s	10.0	0.1	Run
E3.15	Deceleration time 4	0.1...6,000.0 s	10.0	0.1	Run
E3.16	Acceleration time 5	0.1...6,000.0 s	10.0	0.1	Run
E3.17	Deceleration time 5	0.1...6,000.0 s	10.0	0.1	Run
E3.18	Acceleration time 6	0.1...6,000.0 s	10.0	0.1	Run
E3.19	Deceleration time 6	0.1...6,000.0 s	10.0	0.1	Run
E3.20	Acceleration time 7	0.1...6,000.0 s	10.0	0.1	Run

Code	Name	Setting range	Default	Min.	Attri.
E3.21	Deceleration time 7	0.1...6,000.0 s	10.0	0.1	Run
E3.22	Acceleration time 8	0.1...6,000.0 s	10.0	0.1	Run
E3.23	Deceleration time 8	0.1...6,000.0 s	10.0	0.1	Run
E1.00	X1 input	10: Acceleration / deceleration time 1 activation	0	1	Stop
E1.01	X2 input	11: Acceleration / deceleration time 2 activation	0	1	Stop
E1.02	X3 input	12: Acceleration / deceleration time 3 activation	0	1	Stop
E1.03	X4 input		0	1	Stop
E1.04	X5 input		0	1	Stop

Example:

- Set [E1.00] 'X1 input' = '10: Acceleration / deceleration time 1 activation'.
- Set [E1.01] 'X2 input' = '11: Acceleration / deceleration time 2 activation'.
- Set [E1.02] 'X3 input' = '12: Acceleration / deceleration time 3 activation'.

The 'Acceleration / Deceleration time' configuration is shown as below:

X1	X2	X3	Acceleration time	Deceleration time
Inactive	Inactive	Inactive	[E0.26]	[E0.27]
Active	Inactive	Inactive	[E3.10]	[E3.11]
Inactive	Active	Inactive	[E3.12]	[E3.13]
Active	Active	Inactive	[E3.14]	[E3.15]
Inactive	Inactive	Active	[E3.16]	[E3.17]
Active	Inactive	Active	[E3.18]	[E3.19]
Inactive	Active	Active	[E3.20]	[E3.21]
Active	Active	Active	[E3.22]	[E3.23]

Tab. 12-8: Acceleration / deceleration time configuration

Acceleration and deceleration curve mode configuration

Two curve modes are available for acceleration / deceleration: 'linear curve' and 'S-curve'. The S-curve mode is used to achieve a smooth starting or stopping.

Code	Name	Setting range	Default	Min.	Attri.
E0.25	Acceleration / deceleration curve mode	0: Linear mode 1: S-curve	0	-	Stop
E0.28	S-curve starting phase factor	0.0...40.0 %	20.0	0.1	Stop
E0.29	S-curve stopping phase factor	0.0...40.0 %	20.0	0.1	Stop

[E0.25] = 0: Linear mode

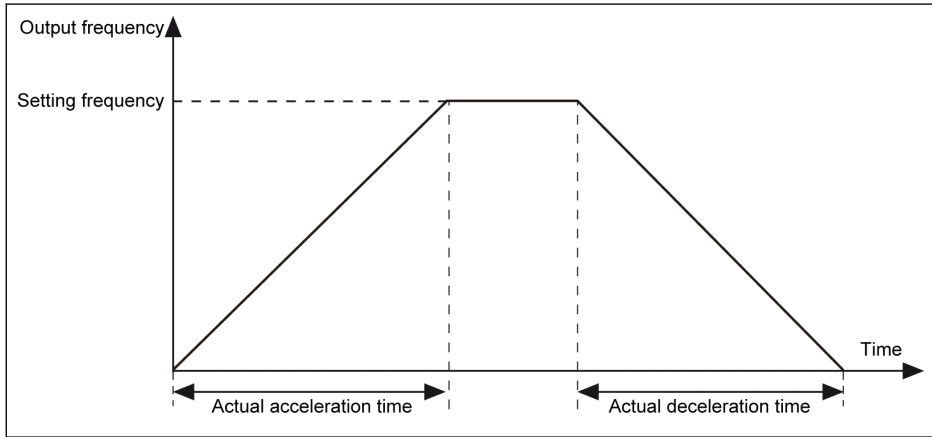
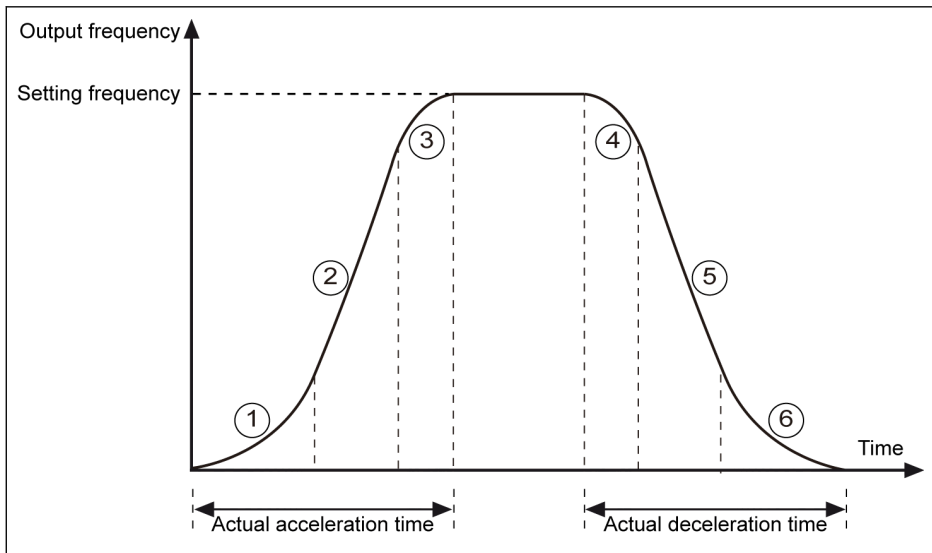

Fig. 12-13: Linear mode acceleration and deceleration

[E0.25] = 1: S-curve



- | | |
|---------------------------------------|---------------------------------------|
| ① [E0.28] Acceleration starting phase | ④ [E0.28] Deceleration starting phase |
| ③ [E0.29] Acceleration stopping phase | ⑥ [E0.29] Deceleration stopping phase |

Fig. 12-14: S-curve acceleration and deceleration



- Stage ①, ③: a percentage of setting acceleration time.
- Stage ④, ⑥: a percentage of setting deceleration time.

12.4.4 Output Frequency Limitation

Direct output frequency limitation

Code	Name	Setting range	Default	Min.	Attri.
E0.08	Maximum output frequency	50.00...400.00 Hz	50.00	0.01	Stop
E0.09	Output frequency high limit	[E0.10]...[E0.08] Hz	50.00	0.01	Run
E0.10	Output frequency low limit	0.00...[E0.09] Hz	0.00	0.01	Run

- Maximum output frequency
The allowed maximum output frequency of the frequency converter.
- Output frequency high limit
The allowed maximum output frequency according to the requirements in actual applications.
- Output frequency low limit
The allowed minimum output frequency according to the requirements in actual applications.

Behavior at low speed running

Code	Name	Setting range	Default	Min.	Attri.
E0.15	Low speed running mode	0: Running at 0 Hz 1: Running at low limit frequency	0	1	Stop
E0.16	Low speed frequency hysteresis	0.00...[E0.10] Hz	0.00	0.01	Stop

By default, the frequency converter runs at 0.00 Hz when the output frequency is lower than [E0.10] 'Output frequency low limit'.

- [E0.15] = 0: Running at 0.00 Hz

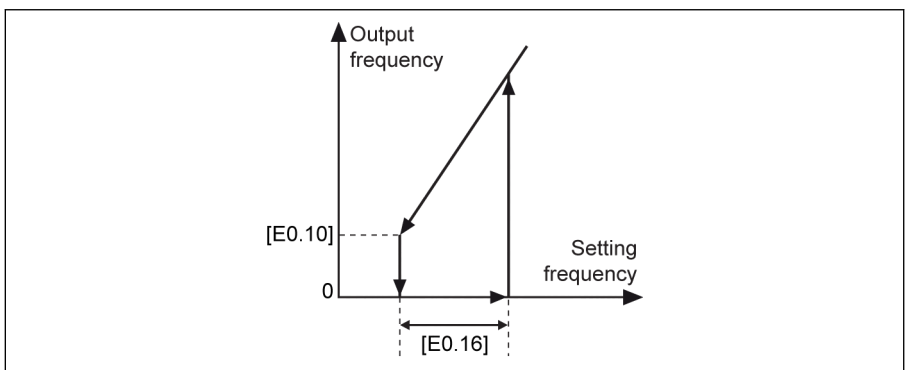

Fig. 12-15: Running at 0.00 Hz

For applications, in which the running frequency cannot be too low, define the low limit frequency running mode when the output frequency is lower than [E0.10] 'Output frequency low limit'.

- [E0.15] = 1: Running at low limit frequency

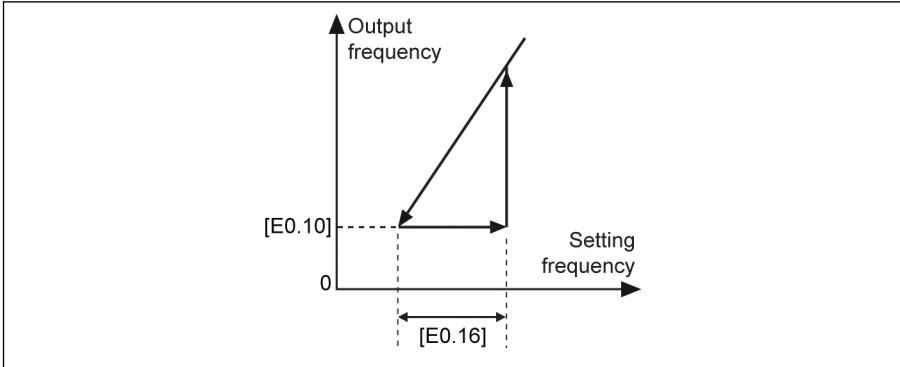

Fig. 12-16: Run with low limit frequency

A hysteresis band is set by [E0.16]. If actual setting frequency is higher than [E0.10] + [E0.16] again, the output frequency will accelerate from [E0.10] to the setting frequency according to the actual acceleration time.

If [E0.10] < [E0.16], [E0.10] will be set as [E0.16] automatically.

12.4.5 Frequency Setting Saving

With the 'Frequency setting saving' function, unexpected data loss of commissioning or actual application engineering process can be avoided. This function is **ONLY** active when 'Digital input Up / Down command' is set as the frequency setting source.

Code	Name	Setting range	Default	Min.	Attri.
E0.06	Digital setting frequency saving mode	0...3	0	1	Stop

- 0: Not saved when powered off or stopped

By default, the setting frequency configured by <▲> / <▼> or X1...X5 digital inputs will not be saved either at power off or frequency converter stop during fine tuning of the setting frequency in the actual application engineering process.

To avoid unexpected data loss of commissioning or actual application engineering process, one of the following three options may be set according to the actual application conditions:

- 1: Not saved when powered off; saved when stopped
- 2: Saved when powered off; not saved when stopped
- 3: Saved when powered off or stopped

12.5 Run- / Stop- / Direction Command Source

12.5.1 Function Description

The Run- / Stop- / Direction Command can be configured by the following means:

- First priority: PID control
- Second priority: Simple PLC
- Third priority: Jog function
- Fourth priority: Basic command sources
 - 0: Operating panel
 - 1: X1...X5 digital inputs
 - 2: Communication

The basic Run- / Stop- / Direction command sources are shown in the figure below:

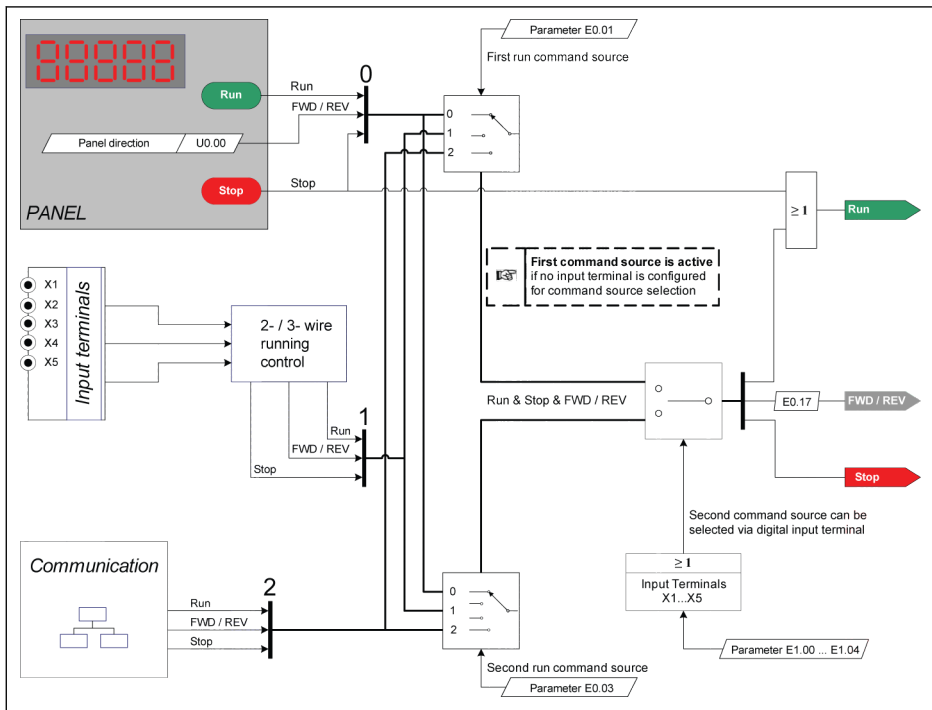

Fig. 12-17: Run command sources

12.5.2 Run Command Source

First and second run command source configuration

Code	Name	Setting range	Default	Min.	Attri.
E0.01	First run command source	0...2	0	1	Stop
E0.03	Second run command source	0...2	1	1	Stop

- 0: Operating panel
Control the frequency converter for run and stop with **<Run>**, **<Stop>** buttons on the operating panel.
Control the running direction by setting parameters U0.00 'Panel control direction' and E0.17 'Direction control'.
- 1: Multi-function digital input
Control the frequency converter for run, stop and running direction by setting X1...X5 digital inputs.
- 2: Communication
Control the frequency converter for run, stop and running direction with Modbus communication protocol.

Switch between first and second run command source

Code	Name	Setting range	Default	Min.	Attri.
E1.00	X1 input	31: Second run command source activation	0	1	Stop
E1.01	X2 input		0	1	Stop
E1.02	X3 input		0	1	Stop
E1.03	X4 input		0	1	Stop
E1.04	X5 input		0	1	Stop

- If status of the selected terminal is changed when converter is running, the run command source will be switched and the converter will freewheel to stop.
- The active / inactive of X1...X5 digital input is triggered by voltage level.

Stop command via panel **<Stop>** button

After the run command source configuration, set U0.01 'Stop button mode' to define the function of **<Stop>** button on the operating panel.

Code	Name	Setting range	Default	Min.	Attri.
U0.01	Stop button mode	0: Active only for operating panel control 1: Active for all control methods	1	1	Run

12.5.3 Direction Control

Direction control via operation panel

The actual direction is controlled by the configuration of parameter [U0.00] 'Panel control direction' and [E0.17] 'Direction control'.

Code	Name	Setting range	Default	Min.	Attri.
U0.00	Panel control direction	0: Forward 1: Reverse	0	1	Run
E0.17	Direction control	0: Forward / Reverse 1: Forward only 2: Reverse only 3: Swap default direction	0	1	Stop

	[E0.17] setting	[U0.00] setting	Actual direction
0	Forward / Reverse	Forward Reverse	Forward Reverse
1	Forward only	Forward Reverse	Forward Converter stop and show error code 'dir1'
2	Reverse only	Forward Reverse	Converter stop and show error code 'dir2' Reverse
3	Swap default direction	Forward Reverse	Reverse Forward

Tab. 12-9: Direction configuration



For error codes 'dir1', 'dir2' concerning direction control, see [chapter 13.4 "Error Code" on page 192](#).

Direction change dead time

A dead time exists if the direction is changed from forward / reverse to reverse / forward, which can be defined according to actual application.

Code	Name	Setting range	Default	Min.	Attri.
E0.18	Direction change dead time	0.0...60.0 s	1.0	0.1	Stop

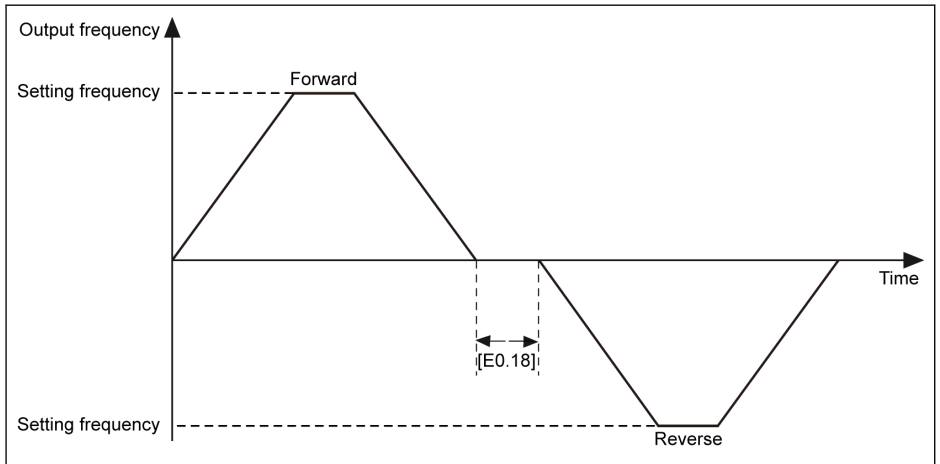

Fig. 12-18: Direction change dead time

12.5.4 Start Behavior Setting

Start mode selection

Code	Name	Setting range	Default	Min.	Attri.
E0.35	Start mode	0: Start directly 1: DC-braking before start 2: Start with speed capture 3: Automatic start / stop according to setting frequency	0	-	Stop

Start directly

This mode is used in applications with high static friction torque and low load inertia. The frequency converter runs at [E0.36] 'Start frequency', for [E0.37] 'Start frequency holding time', and then accelerates to setting frequency with defined acceleration time.

Code	Name	Setting range	Default	Min.	Attri.
E0.36	Start frequency	0.00...50.00 Hz	0.05	0.01	Stop
E0.37	Start frequency holding time	0.0...20.0 s	0.1	0.1	Stop

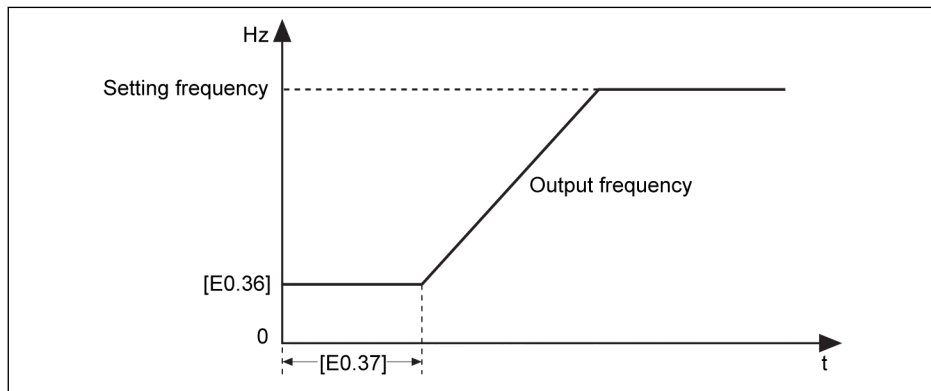

Fig. 12-19: Start directly



Set parameter E0.37 'Start frequency holding time' to a non-zero value when the motor needs to be started with certain start frequency.

DC-braking before start



DC-braking is used in applications, in which regular deceleration to stop or a quick stop is required. The larger DC-braking current, the larger braking force. However, the withstanding capability of the motor has to be considered before use the DC-braking function.

'DC-braking before start' is used in applications where the load may encounter forward / reverse rotation when the frequency converter is in stop mode.

Code	Name	Setting range	Default	Min.	Attri.
E0.38	Start DC-braking time	0.0...20.0 s	0.0	0.1	Stop
E0.39	Start DC-braking current	0.0...150.0 %	0.0	0.1	Stop

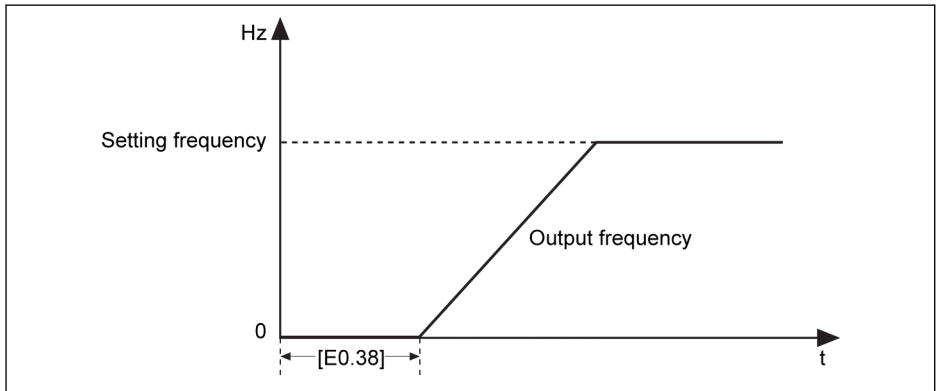

Fig. 12-20: DC-braking before start

When [E0.38] \neq 0, DC-braking will be executed before the frequency converter starting to accelerate to [E0.36] 'Start frequency'.

Start with speed capture

This mode is used after transient power fault in applications with a large inertia load. The frequency converter firstly identifies the rotation speed and direction of the motor, and then starts with the current frequency of the motor to realize smooth starting without shock to the rotating motor.

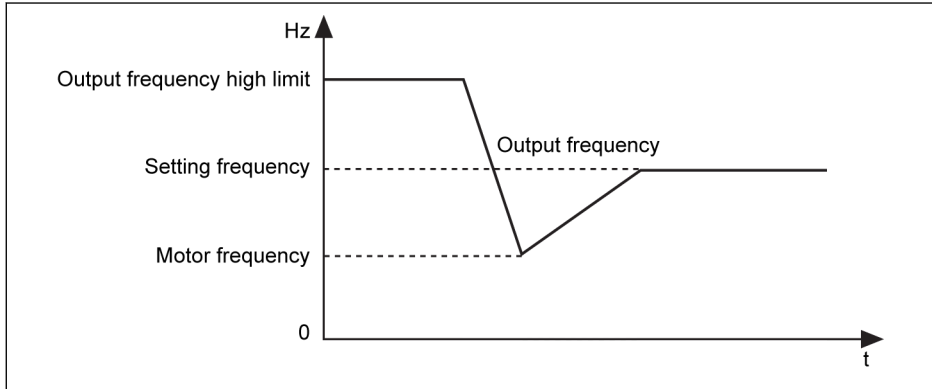

Fig. 12-21: Start with speed capture



When the frequency converter is starting and accelerating, if 'Setting frequency' is lower than [E0.36] 'Start frequency', the frequency converter firstly starts at 'Start frequency' and runs for [E0.37] 'Start frequency holding time', and then decelerates to 'Setting frequency'.

Automatic start / stop according to setting frequency

With this function, the converter starts when the setting frequency from analog input is higher than the threshold, and stops when the setting frequency from analog input is lower than the threshold. The threshold is set by parameter E0.41 'Automatic start / stop frequency threshold'.

To use this function, follow the rules below:

- The frequency setting source should be set to AI1 or AI2.
- The first and second run command source should be set to '0: Panel'.

Code	Name	Setting range	Default	Min.	Attri.
E0.35	Starting mode	3: Auto start / stop according to setting frequency	0	1	Stop
E0.41	Automatic start / stop frequency threshold	0.01...[E0.09] Hz	16.00	0.01	Stop
E0.00	First frequency setting source	2: AI1 analog input	0	1	Stop
E0.02	Second frequency setting source	3: AI2 analog input	2	1	Stop
E0.01	First run command source	0: Panel	0	1	Stop
E0.03	Second run command source		1	1	Stop

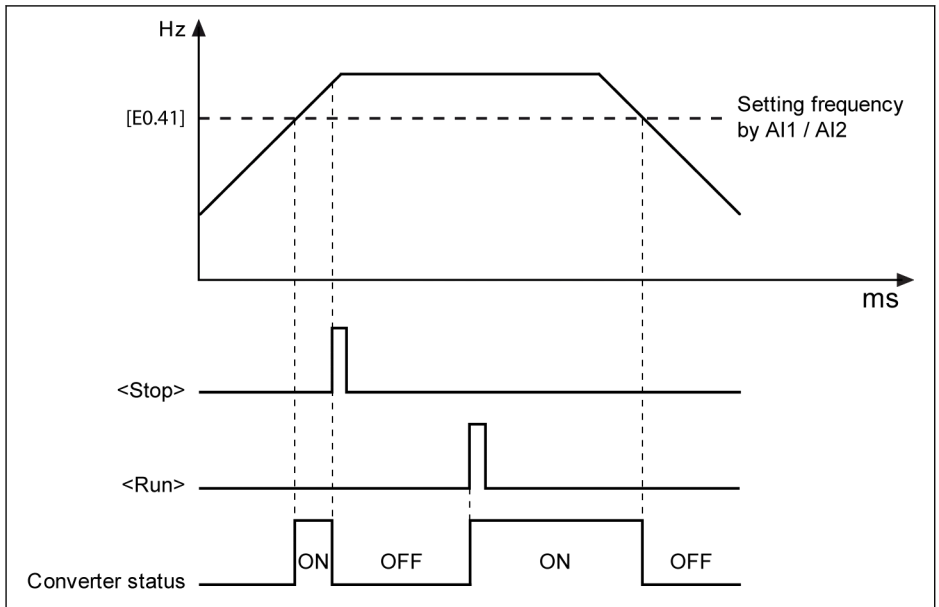

Fig. 12-22: Automatic start or stop according to frequency threshold

- When the setting frequency is higher than [E0.41], the frequency converter starts and runs to the setting frequency automatically.

- Pressing <Stop> at this time, the frequency converter stops.
- Pressing <Run> again, the frequency converter runs again.
- When the setting frequency is lower than [E0.41], the frequency converter stops automatically.



- If the threshold [E0.41] is set higher than the setting frequency high limit [E0.09], the threshold will be limited to the high limit [E0.09].
- Make sure that:
 - The first and the second run command sources are both via panel.
 - The active frequency setting source is via AI1 or AI2.
 - The Simple PLC, PID control and Jog function are deactivated.

Otherwise, E0.35 'Starting mode' cannot be set to '3: Auto start / stop according to setting frequency'. In this case, warning code 'PrSE' will be displayed and the frequency converter keeps in stop status.

12.5.5 Stop Behavior Setting

Stop mode setting

Code	Name	Setting range	Default	Min.	Attri.
E0.50	Stop mode	0...2	0	1	Stop
E1.00	X1 input	15: Freewheeling stop activation	0	1	Stop
E1.01	X2 input		0	1	Stop
E1.02	X3 input		0	1	Stop
E1.03	X4 input		0	1	Stop
E1.04	X5 input		0	1	Stop

- [E0.50] = 0: Deceleration stop

The motor decelerates to stop according to the defined deceleration time.

If 'Output frequency' is lower than [E0.52] 'Stop DC-braking initial frequency' and 'Stop DC-braking time' [E0.53] $\neq 0$, and then DC-braking is activated. The 'Stop DC-braking current' is decided by [E0.54].

- [E0.50] = 1: Freewheeling stop

Once the stopping command is activated, the converter stops output and the motor mechanically freewheels to stop.

'Freewheeling stop' can also be activated by X1...X5 digital inputs. When the digital input signal is active, the frequency converter freewheels to stop. If the digital input signal is inactive and a run command is active, the frequency converter resumes the previous running status.

- [E0.50] = 2: Freewheeling with stop command, decelerating with direction change
 - When stopping command is active, the motor freewheels to stop as [E0.50] = 1.
 - When direction command is changed during running, the motor decelerates to stop according to the defined deceleration time as [E0.50] = 0.



If an error occurs due to too fast deceleration, increase the deceleration time or calculate if additional resistor braking is necessary.

DC-braking during deceleration to stop

Code	Name	Setting range	Default	Min.	Attri.
E0.50	Stop mode	0: Decelerating stop	0	1	Stop
E0.52	Stop DC-braking frequency threshold	0.00...50.00 Hz	0.00	0.00 0.01	Stop
E0.53	Stop DC-braking time	0.0...20.0 s (0.0: Inactive)	0.0	0.1	Stop
E0.54	Stop DC-braking current	0.0...150.0 %	0.0	0.1	Stop
E1.00	X1 input	16: Stop DC-braking activation	0	1	Stop
E1.01	X2 input		0	1	Stop
E1.02	X3 input		0	1	Stop
E1.03	X4 input		0	1	Stop
E1.04	X5 input		0	1	Stop

'DC-braking to stop' can be activated in two ways:

- by parameter settings
 - [E0.50] = 0
 - [E0.53] > 0
 - [E0.54] > 0
 - [Output frequency] ≤ [E0.52]
- by X1...X5 digital inputs
 - Any one of X1...X5 digital inputs is set to '16: Stop DC-braking activation'
 - [E0.50] = 0

DC-braking starts when the defined digital input signal is active, and stops when it is inactive. There is no time limitation.

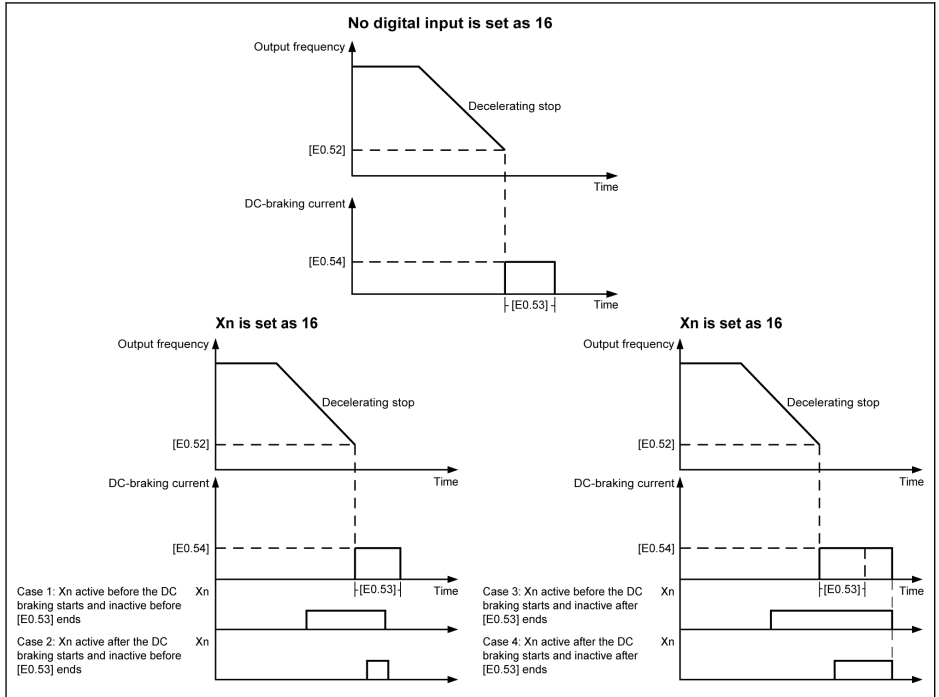

Fig. 12-23: Stop DC-braking

Overexcitation braking

This function is used to obtain an optimized braking performance of the frequency converter in V/f control mode. To realize this function, increase 'Converter output voltage' by fine tuning of parameter E0.55 'Overexcitation braking factor' during deceleration process.

Code	Name	Setting range	Default	Min.	Attri.
E0.55	Overexcitation braking factor	1.00...1.40	1.10	0.01	Run

- When [E0.55] = 1.00, 'Overexcitation braking' is inactive.
- A higher factor brings a higher braking force.

However, an excessive high factor may trigger errors of overcurrent (OC-1, OC-2, OC-3), converter overload (OL-1), or motor overload (OL-2). Reduce the setting of the factor in such cases.

12.5.6 Resistor Braking

This function is used to obtain an optimized braking performance of the frequency converter in either V/f control mode or SVC control mode.

By default, the resistor braking is disabled. This function can **NOT** be activated when the converter is in stop status.

Code	Name	Setting range	Default	Min.	Attri.
C0.25	Overvoltage prevention mode	2: Stall overvoltage protection disabled, resistor braking enabled	0	1	Stop
C0.15	Braking start point	1P 200 VAC: 300...390 V 3P 400 VAC: 600...785 V	390 770	1	Stop
C0.16	Braking duty cycle	1...100%	100	1	Stop

To use this function, take the following steps:

Step 1: Activate the resistor braking function

Set [C0.25] = '2: Stall overvoltage protection disabled, resistor braking enabled'.

Step 2: Set the braking point based on model

The default 'Braking start point' is different for 3P 400 VAC and 1P 200 VAC models, which needs to be adjusted by setting parameter C0.15 'Braking start point' according to the actual situations.

Step 3: Set the duty cycle

Set parameter C0.16 'Braking duty cycle' according to the actual situations:

- When the DC-bus voltage is higher than [C0.15] 'Braking start point', the brake chopper switches On / Off according to the duty [C0.16] 'Braking duty cycle' with an internal hysteresis.
- Excessive low setting of parameter C0.16 'Braking duty cycle' may bring over-voltage error during braking.

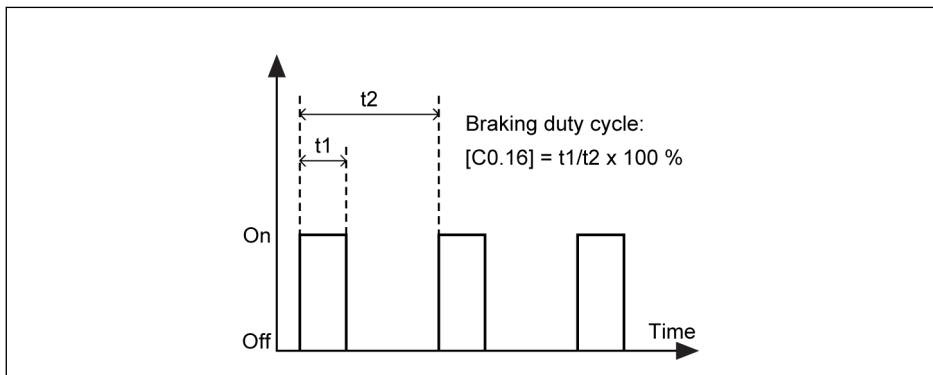

Fig. 12-24: Braking duty cycle

$$t1 = t2 \times [C0.16] / 100 \% ; t2 = 1 / 100 \text{ Hz} = 10 \text{ ms}$$

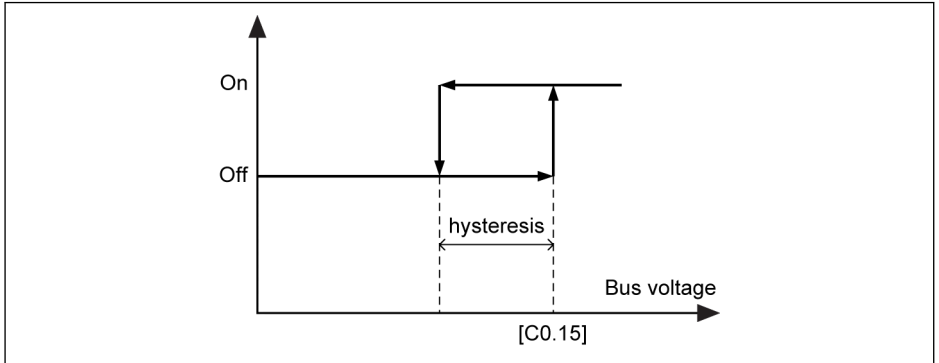

Fig. 12-25: Hysteresis

The hysteresis for different models is as listed below:

- 1P 200 VAC: 24 V
- 3P 400 VAC: 10 V

12.6 Special Running Behaviors

12.6.1 Skip Frequency

This function is used to avoid the mechanical resonance of the motor by definition of skip frequencies.

Code	Name	Setting range	Default	Min.	Attri.
E0.70	Skip frequency 1	0.00...[E0.09] Hz	0.00	0.01	Stop
E0.71	Skip frequency 2	0.00...[E0.09] Hz	0.00	0.01	Stop
E0.72	Skip frequency 3	0.00...[E0.09] Hz	0.00	0.01	Stop
E0.73	Skip frequency range	0.00...30.00 Hz	0.00	0.01	Stop
E0.74	Skip window acceleration factor	1...100	1	1	Stop

The setting ranges of the three skip frequencies are shown in the figure below:

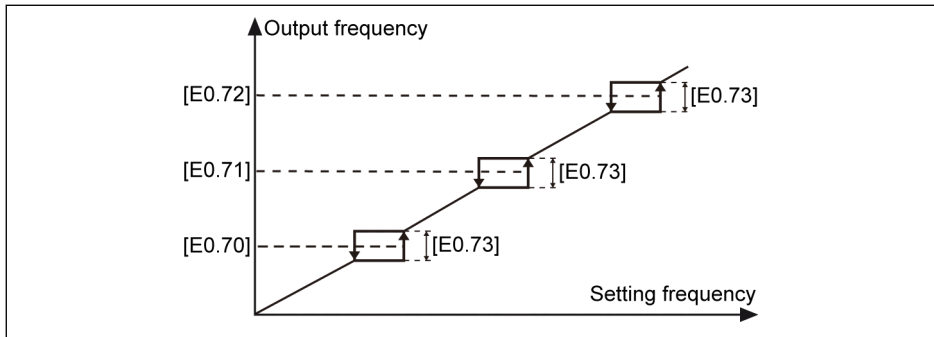

Fig. 12-26: Skip frequency

Skip frequency points are defined by parameters E0.70...E0.72. Skip frequency range or boundaries are defined by parameter E0.73 as listed below:

- [Upper boundary frequency] = [Skip frequency] + [E0.73]/2
- [Lower boundary frequency] = [Skip frequency] - [E0.73]/2

If the current 'Output frequency' is higher than the 'Upper boundary frequency', and the target 'Setting frequency' is within the 'Skip frequency range', the actual output frequency will be limited to 'Lower boundary frequency'.

If the current 'Output frequency' is lower than the 'Lower boundary frequency', and the target 'Setting frequency' is within the 'Skip frequency range', the actual output frequency will be limited to 'Upper boundary frequency'.



- If [E0.73] = 0.00, 'Skip frequency' function is inactive.
- Do **NOT** set E0.70, E0.71 and E0.72 overlapping or nesting in each other.

Parameter E0.74 is used to control the acceleration / deceleration speed inside the skip-window, the range for this factor is 1 (normal speed) to 100 (100 times speed of the normal speed).



The actual acceleration / deceleration time for skip frequency is shorter than the setting value when the factor is higher than 1.

12.6.2 Jog Function

The 'Jog command' has a higher priority than and is independent of the 'Run / Stop command'. This function can **ONLY** be set by X1...X5 input or communication. To use this function, take the following steps:

Step 1: Select any 2 X1...X5 digital inputs

Code	Name	Setting range	Default	Min.	Attri.
E1.00	X1 input	37: Forward jog 38: Reverse jog	0	1	Stop
E1.01	X2 input		0	1	Stop
E1.02	X3 input		0	1	Stop
E1.03	X4 input		0	1	Stop
E1.04	X5 input		0	1	Stop

Step 2: Set respective parameters

Code	Name	Setting range	Default	Min.	Attri.
E0.60	Jog frequency	0.00...[E0.08] Hz	5.00	0.01	Run
E0.61	Jog acceleration time	0.1...6000.0 s	5.0	0.1	Run
E0.62	Jog deceleration time	0.1...6000.0 s	5.0	0.1	Run

Once the 'Jog command' is active, the frequency converter runs immediately to [E0.60] 'Jog frequency' with acceleration / deceleration time defined by 'Jog acceleration time' [E0.61] / 'Jog deceleration time' [E0.62] no matter the converter is running or not. When 'Jog command' is inactive, the motor resumes the previous status.

● Converter is at stop

- 'Jog command' active: Accelerate to [E0.60] 'Jog frequency' according to [E0.61] 'Jog acceleration time'.
- 'Jog command' inactive: Deceleration time is according to [E0.62] 'Jog deceleration time'.

● Converter is running

- 'Output frequency' is higher than 'Jog frequency'
 - 'Jog command' active: Decelerate to [E0.60] 'Jog frequency' according to [E0.62] 'Jog deceleration time'.
 - 'Jog command' inactive: Accelerate to previous 'Setting frequency' according to [E0.26] 'Acceleration time'.
- 'Output frequency' is lower than 'Jog frequency'
 - 'Jog command' active: Accelerate to [E0.60] 'Jog frequency' according to [E0.61] 'Jog acceleration time'.
 - 'Jog command' inactive: Decelerate to prior 'Setting frequency' according to [E0.27] 'Deceleration time'.

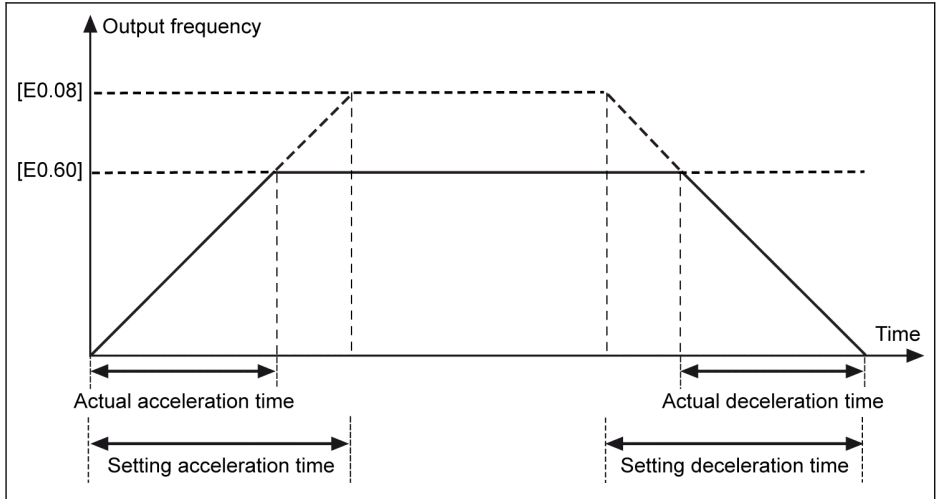

Fig. 12-27: Jog acceleration / deceleration time

Forward jog	Reverse jog	Running status
Active	Active	Stop
Active	Inactive	Jog forward
Inactive	Active	Jog reverse

Tab. 12-10: Jog configuration



If the jog command direction does not match the current jog running direction, the converter will stop according to [E0.50] 'Stopping mode'.

12.6.3 2-wire / 3-wire Control (Forward / stop, reverse / stop)

2-wire control mode 1

Step 1: Activate 2-wire control mode 1

Set [E1.15] = '0: Forward / stop, reverse / stop'.

Step 2: Define two digital inputs

- Set one of X1...X5 input as '35: Forward running (FWD)'
- Set one of X1...X5 input as '36: Reverse running (REV)'

Example:

Connected switch K1 to X1, and set [E1.00] = '35: Forward running (FWD)'.

Connected switch K2 to X2, and set [E1.01] = '36: Reverse running (REV)'.

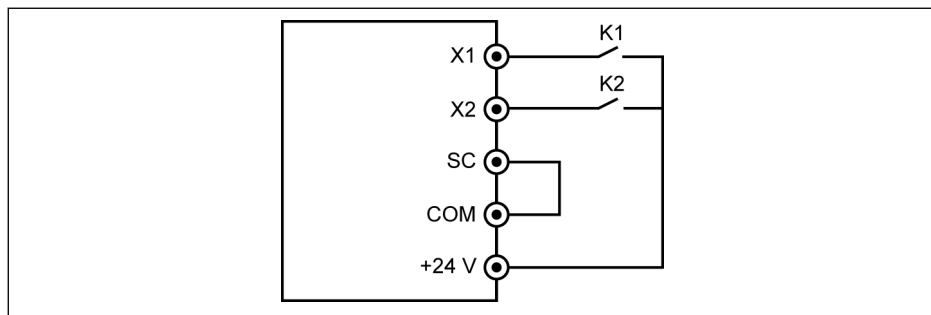

Fig. 12-28: 2-wire control mode 1

The control logic is shown in the table below:

K1	K2	Running status
Open	Open	Stop
Closed	Open	Running forward
Open	Closed	Running reverse
Closed	Closed	Stop

Tab. 12-11: 2-wire control mode 1 configuration



If switch K1 and K2 are closed at the same time, the frequency converter stops according to [E0.50] 'Stop mode' and both FWD and REV LED indicators are lighted during stop status.

2-wire control mode 2 (Forward / reverse, run / stop)**Step 1: Activate 2-wire control mode 2**

Set [E1.15] = '1: Forward / reverse, run / stop'.

Step 2: Define two digital inputs

- Set one of X1...X5 input as '35: Forward running (FWD)'
- Set one of X1...X5 input as '36: Reverse running (REV)'

Example:

Connected switch K1 to X1, and set [E1.00] = '35: Forward running (FWD)'.

Connected switch K2 to X2, and set [E1.01] = '36: Reverse running (REV)'.

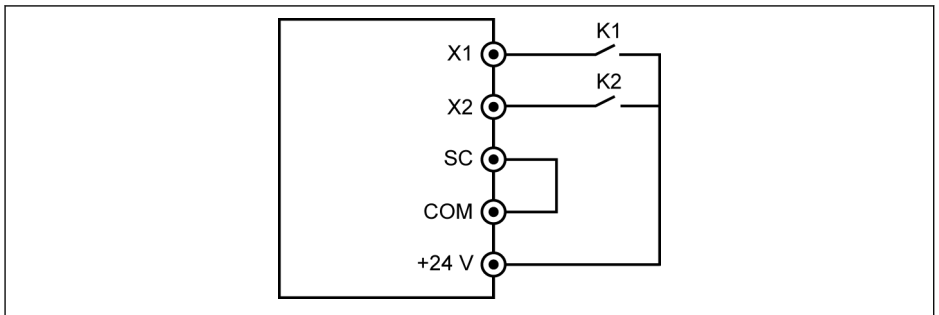

Fig. 12-29: 2-wire control mode 2

The control logic is shown in the table below:

K1	K2	Running status
Open	Open	Stop
Closed	Open	Running forward
Open	Closed	Stop
Closed	Closed	Running reverse

Tab. 12-12: 2-wire control mode 2 configuration

3-wire control mode 1

Step 1: Define 3 digital inputs

- Set one X1...X5 input as '35: Forward running (FWD)'
- Set one X1...X5 input as '36: Reverse running (REV)'
- Set one X1...X5 input as '25: 3-wire running control'

To use 3-wire function, define the digital inputs first, and then activate the control mode. Otherwise, warning code 'PrSE' will be displayed on the operating panel.

To deactivate the 3-wire function, deactivate the control mode first, and then deactivate the function assignment of '25: 3-wire running control'. Otherwise, warning code 'PrSE' will be displayed.

Step 2: Activate 3-wire control 1

Set [E1.15] = '2: 3-wire control 1'.

Example:

Connected switch K1 to X1, and set [E1.00] = '35: Forward running (FWD)', edge-sensitive.

Connected switch K2 to X2, and set [E1.01] = '36: Reverse running (REV)', level-sensitive.

Connected switch K3 to X3, and set [E1.02] = '25: 3-wire running control', level-sensitive.

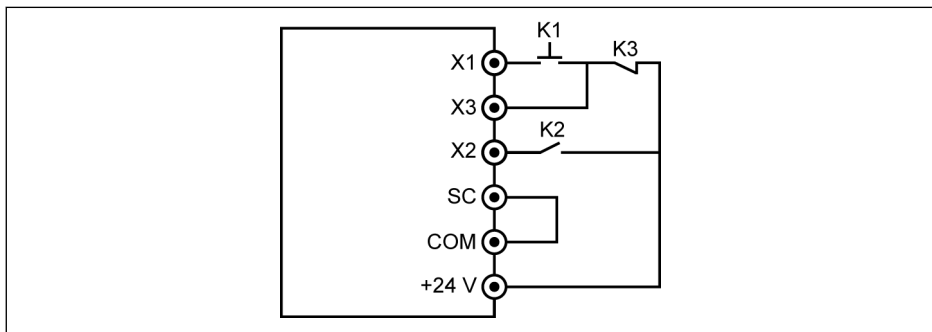

Fig. 12-30: 3-wire control 1

The control logic is shown in the table below:

K3	K1	K2	Running status
Open	Inactive / Edge	Open / Closed	Stop
Open	Inactive / Edge	Open / Closed	Stop
Closed	Edge	Open	Running forward
Closed	Inactive / Edge	Closed	Running reverse

Tab. 12-13: 3-wire control configuration

3-wire control mode 2

Different from the 3-wire control mode 1, 3-wire control mode 2 has an edge sensitive characteristic for direction control terminals.

Step 1: Define 3 digital inputs

- Set one X1...X5 input as '35: Forward running (FWD)'
- Set one X1...X5 input as '36: Reverse running (REV)'
- Set one X1...X5 input as '25: 3-wire running control'

Step 2: Activate 3-wire control mode 2

Set [E1.15] = '3: 3-wire control mode 2'.

Example:

Connected switch K1 to X1, and set [E1.00] = '35: Forward running (FWD)', edge-sensitive.

Connected switch K2 to X2, and set [E1.01] = '36: Reverse running (REV)', edge-sensitive.

Connected switch K3 to X3, and set [E1.02] = '25: 3-wire running control', level-sensitive.

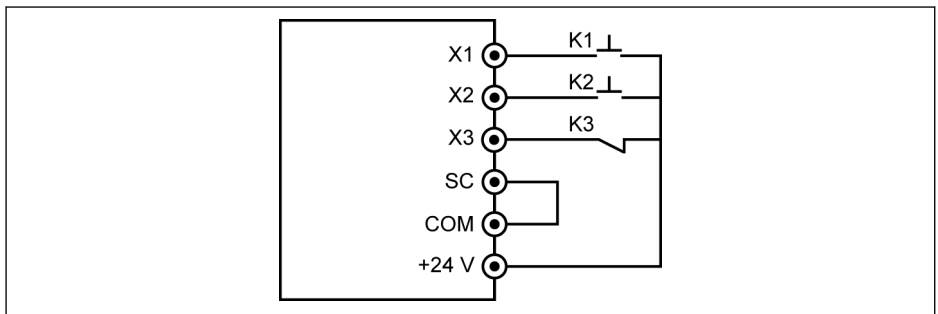

Fig. 12-31: 3-wire control mode 2

The control logic is shown in the table below:

K3	K1	K2	Running status
Open	Edge / Inactive	Edge / Inactive	Stop
Closed	Edge	Inactive	Running forward
Closed	Inactive	Edge	Running reverse
Closed	Edge	Edge	No change

Tab. 12-14: 3-wire control configuration



In 2-wire / 3-wire running control, check and ensure that the direction setting meets the requirement in the actual application. If the direction command is changed when the frequency converter is running, [E0.18] 'direction change dead time' is active.

Run / Stop

For details of Run /Stop mode, see [chapter "Adjust the setting frequency by multi-speed function" on page 103](#).

12.7 Special Functions

12.7.1 Counter Function

The internal counter counts the input pulses received from 'X1...X5 input' and compares it with the setting value of 'Counter middle value' or 'Counter target value'.

The 'Middle counter value arrival' or 'Target counter value arrival' output signal will be indicated via DO1 or Relay1 output when the counter value equals to that of setting value.

The counter is cleared and the DO1 or Relay1 output signal is reset by a valid edge signal of another digital input defined as 'Counter reset'.

Code	Name	Setting range	Default	Min.	Attri.
E1.00	X1 input	39: Counter input 40: Counter reset	0	1	Stop
E1.01	X2 input		0	1	Stop
E1.02	X3 input		0	1	Stop
E1.03	X4 input		0	1	Stop
E1.04	X5 input		0	1	Stop
E2.80	Counter middle value	0...[E2.81]	0	1	Run
E2.81	Counter target value	[E2.80]...9,999	0	1	Run
E2.01	DO1 output selection	16: Target counter value arrival	1	1	Stop
E2.15	Relay1 output selection	17: Middle counter value arrival	1	1	Stop

Example:

X1 input is defined as '39: Counter input'.

X2 input is defined as '40: Counter reset'.

The wiring is shown as the figure below:

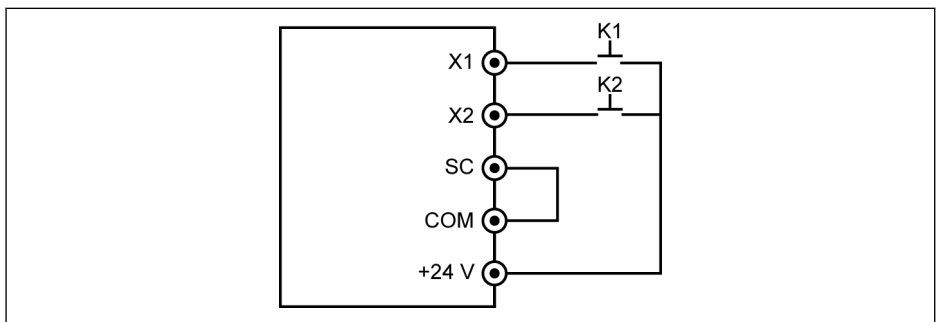

Fig. 12-32: Digital input configuration

Connected K1 to X1, and set [E1.00] = '39: Counter input'.

Connected K2 to X2, and set [E1.01] = '40: Counter reset'.

K1	K2	Running status	Status
Inactive	Inactive	–	–
Edge	Inactive	Counter value = [E2.80] / [E2.81]	Internal counter value stays at [E2.80] / [E2.81] Digital output is active
Edge	Edge	Counter is reset	Internal counter value is reset to '0' Digital output is inactive

Tab. 12-15: Counter function

'DO1 output' or 'Relay1 output' signal and status are as below:

- [E2.01] / [E2.15] = '16: Target counter value arrival'
When the internal counter receives from 'X1 input' the number of input pulse, which equals to [E2.81] 'Counter target value'.
- [E2.01] / [E2.15] = '17: Middle counter value arrival'
When the internal counter receives from 'X1 input' the number of input pulse, which equals to [E2.80] 'Counter middle value'.

The signal is reset by the next valid edge signal of 'X2 input' which is defined as '40: Counter reset'.

Example:

[E2.80] = 5, [E2.81] = 8

The output behavior is described as below:

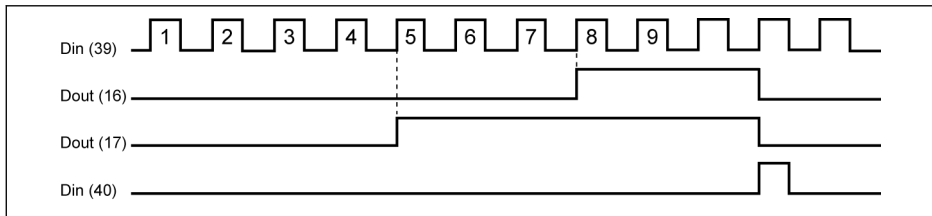

Fig. 12-33: Output behavior



- If the setting of any parameter E2.80, E2.81 and / or the status of the defined digital inputs is changed, the counter value will be reset and the digital outputs will be inactive immediately.
- The allowed maximum digital input frequency is 50 Hz and the allowed minimum pulse width (both active and inactive) is higher than 8 ms.

12.7.2 Frequency Arrival

This function is used to detect the difference between the output frequency and the setting frequency. When the difference is within the frequency detection width, an indication signal will be generated for further engineering in the application.

Code	Name	Setting range	Default	Min.	Attri.
E2.01	DO1 output selection	4: Speed arrival	1	-	Stop
E2.15	Relay1 output selection		1	-	Stop
E2.70	Frequency detection width	0.00...400.00 Hz	2.50	0.01	Run

The 'Speed arrival' signal is active on 'DO1 output' or 'Relay1 output' when the difference between the 'Output frequency' and the 'Setting frequency' is within the range set by parameter E2.70 'Frequency detection width':

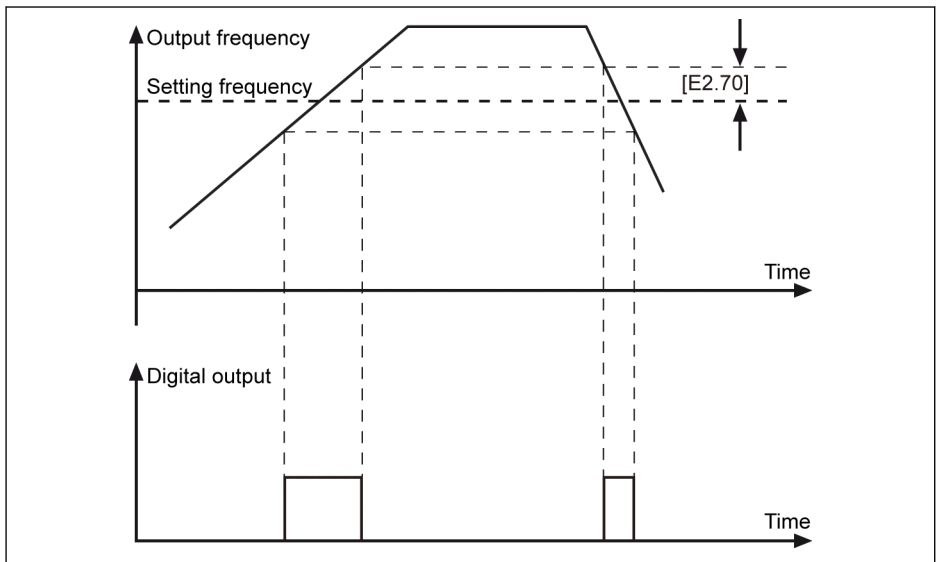

Fig. 12-34: Frequency arrival

12.7.3 Frequency Level Detection

This function is used to detect the difference between the output frequency and the setting frequency. An indication signal will be generated **ONLY** when the output frequency is **HIGHER** than the lower limit of the frequency detection level. The indication signal can be used for further engineering in the application.

Code	Name	Setting range	Default	Min.	Attri.
E2.01	DO1 output selection	5, 6	1	-	Stop
E2.15	Relay1 output selection		1	-	Stop
E2.71	Frequency detection level FDT1	0.00...400.00 Hz	50.00	0.01	Run
E2.72	Frequency detection level FDT1 width	0.00...[E2.71] Hz	1.00	0.01	Run
E2.73	Frequency detection level FDT2	0.00...400.00 Hz	25.00	0.01	Run
E2.74	Frequency detection level FDT2 width	0.00...[E2.73] Hz	1.00	0.01	Run

'DO1 output' or 'Relay1 output' signal and status are as below:

- [E2.01] / [E2.15] = 5: Frequency level detection signal (FDT1)
 - Active when 'Output frequency' is higher than [E2.71]
 - Inactive when 'Output frequency' is lower than [E2.71] - [E2.72]
- [E2.01] / [E2.15] = 6: Frequency level detection signal (FDT2)
 - Active when 'Output frequency' is higher than [E2.73]
 - Inactive when 'Output frequency' is lower than [E2.73] - [E2.74]

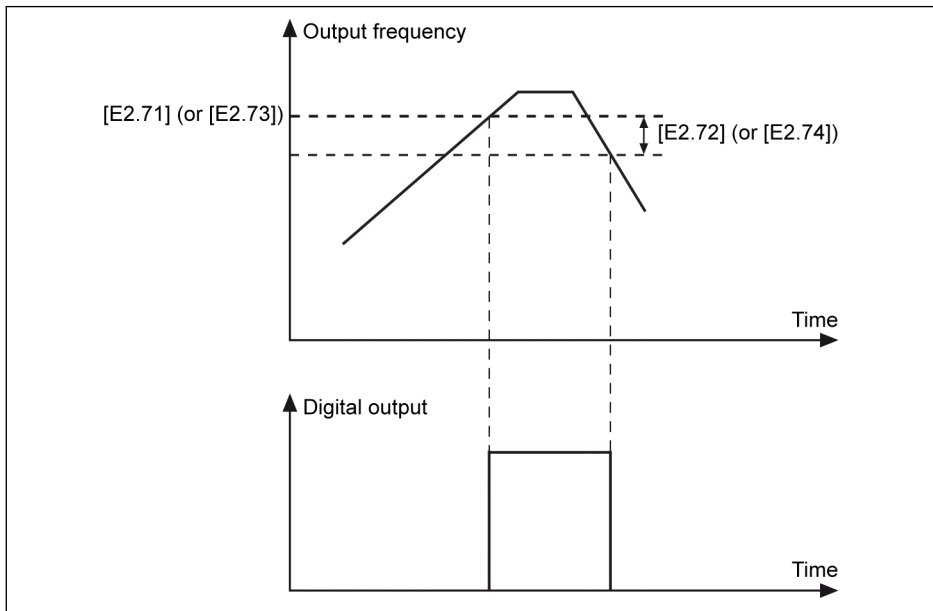

Fig. 12-35: Frequency level detection

12.7.4 High Resolution Current Display

Code	Name	Setting range	Default	Min.	Attri.
E5.01	High resolution output current filter time	5...500 ms	40	1	Run
d0.98	High resolution output current	-	-	0.01	Read

E5.01 is used to set the time constant of dynamic output current in applications where a high resolution value with two decimals are required for monitoring or control.

12.8 Simple PLC

12.8.1 Function Description

Simple PLC is an automatic running mode based on the current acceleration / deceleration time, setting frequency, duration and rotation direction.

Simple PLC consists of 16 stages, each of which has its own settings of acceleration time, deceleration time, setting frequency, rotation direction and duration. An example of simple PLC control is shown in the figure below:

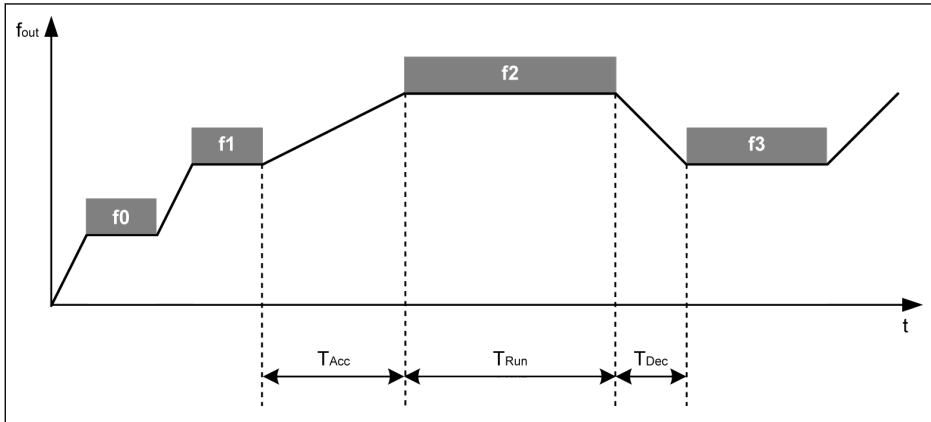

f_{out} Output frequency
 t Time
 T_{Acc} Acceleration time

T_{Run} Stage running time
 T_{Dec} Deceleration time

Fig. 12-36: Example of simple PLC control

Frequency source	Run command source	Rotation direction and Acc. / Dec. time
Simple PLC	Operating panel	[E3.60], [E3.62], [E3.64], [E3.66]
	Multi-function digital input	[E3.68], [E3.70], [E3.72], [E3.74]
	Communication	[E3.76], [E3.78], [E3.80], [E3.82] [E3.84], [E3.86], [E3.88], [E3.90]

Tab. 12-16: Simple PLC configuration

12.8.2 Set the Simple PLC Mode

Code	Name	Setting range	Default	Min.	Attri.
E3.00	Simple PLC running mode	0...3	0	–	Stop
E3.01	Simple PLC time multiplier	1...60	1	1	Stop
E3.02	Simple PLC cycle number	1...1,000	1	1	Stop

- [E3.00] = 0: Inactive
- [E3.00] = 1: Stop after selected cycle

In this mode, the frequency converter decelerates to 0.00 Hz after the last stage of simple PLC, and then stops according to the configured stopping mode.

- [E3.00] = 2: Continuously cycling

In this mode, the frequency converter decelerates to 0.00 Hz after the last stage of simple PLC, and then starts a new cycle automatically.

- [E3.00] = 3: Run with last stage after selected cycle

In this mode, the frequency converter keeps running at the setting frequency of the last stage of simple PLC.

The actual duration for each stage is defined by following equation (Take stage 0 as an example):

$$T_{\text{Run}} = [E3.61] \times [E3.01]$$

Based on the equation above, the maximum duration of one cycle is:

$$8 \times 6,000.0 \text{ s} \times 60 = 800 \text{ hours.}$$

12.8.3 Set Speed / Direction / Acceleration and Deceleration Time

Code	Name	Setting range	Default	Min.	Attri.
E0.07	Digital setting frequency	0.00...[E0.09] Hz	50.00	0.01	Run
E3.40	Multi-speed frequency 1	0.00...[E0.09] Hz	0.00	0.01	Run
E3.41	Multi-speed frequency 2	0.00...[E0.09] Hz	0.00	0.01	Run
E3.42	Multi-speed frequency 3	0.00...[E0.09] Hz	0.00	0.01	Run
E3.43	Multi-speed frequency 4	0.00...[E0.09] Hz	0.00	0.01	Run
E3.44	Multi-speed frequency 5	0.00...[E0.09] Hz	0.00	0.01	Run
E3.45	Multi-speed frequency 6	0.00...[E0.09] Hz	0.00	0.01	Run
E3.46	Multi-speed frequency 7	0.00...[E0.09] Hz	0.00	0.01	Run
E3.47	Multi-speed frequency 8	0.00...[E0.09] Hz	0.00	0.01	Run
E3.48	Multi-speed frequency 9	0.00...[E0.09] Hz	0.00	0.01	Run
E3.49	Multi-speed frequency 10	0.00...[E0.09] Hz	0.00	0.01	Run
E3.50	Multi-speed frequency 11	0.00...[E0.09] Hz	0.00	0.01	Run
E3.51	Multi-speed frequency 12	0.00...[E0.09] Hz	0.00	0.01	Run
E3.52	Multi-speed frequency 13	0.00...[E0.09] Hz	0.00	0.01	Run
E3.53	Multi-speed frequency 14	0.00...[E0.09] Hz	0.00	0.01	Run
E3.54	Multi-speed frequency 15	0.00...[E0.09] Hz	0.00	0.01	Run
E3.60	Stage 0 action		011	-	Stop
E3.62	Stage 1 action	011, 012, 013, 014, 015, 016, 017, 018, 021, 022, 023, 024, 025, 026, 027, 028, 031, 032, 033, 034, 035, 036, 037, 038, 041, 042, 043, 044, 045, 046, 047, 048, 051, 052, 053, 054, 055, 056, 057, 058, 061, 062, 063, 064, 065, 066, 067, 068, 071, 072, 073, 074, 075, 076, 077, 078, 081, 082, 083, 084, 085, 086, 087, 088, 111, 112, 113, 114, 115, 116, 117, 118, 121, 122, 123, 124, 125, 126, 127, 128, 131, 132, 133, 134, 135, 136, 137, 138, 141, 142, 143, 144, 145, 146, 147, 148, 151, 152, 153, 154, 155, 156, 157, 158, 161, 162, 163, 164, 165, 166, 167, 168, 171, 172, 173, 174, 175, 176, 177, 178, 181, 182, 183, 184, 185, 186, 187, 188	011	-	Stop
E3.64	Stage 2 action		011	-	Stop
E3.66	Stage 3 action		011	-	Stop
E3.68	Stage 4 action		011	-	Stop
E3.70	Stage 5 action		011	-	Stop
E3.72	Stage 6 action		011	-	Stop
E3.74	Stage 7 action		011	-	Stop
E3.76	Stage 8 action		011	-	Stop
E3.78	Stage 9 action		011	-	Stop
E3.80	Stage 10 action		011	-	Stop
E3.82	Stage 11 action		011	-	Stop
E3.84	Stage 12 action		011	-	Stop
E3.86	Stage 13 action		011	-	Stop
E3.88	Stage 14 action		011	-	Stop
E3.90	Stage 15 action		011	-	Stop
E3.61	Stage 0 running time	0.0...6,000.0 s	20.0	0.1	Stop
E3.63	Stage 1 running time	0.0...6,000.0 s	20.0	0.1	Stop
E3.65	Stage 2 running time	0.0...6,000.0 s	20.0	0.1	Stop

Code	Name	Setting range	Default	Min.	Attri.
E3.67	Stage 3 running time	0.0...6,000.0 s	20.0	0.1	Stop
E3.69	Stage 4 running time	0.0...6,000.0 s	20.0	0.1	Stop
E3.71	Stage 5 running time	0.0...6,000.0 s	20.0	0.1	Stop
E3.73	Stage 6 running time	0.0...6,000.0 s	20.0	0.1	Stop
E3.75	Stage 7 running time	0.0...6,000.0 s	20.0	0.1	Stop
E3.77	Stage 8 running time	0.0...6,000.0 s	20.0	0.1	Stop
E3.79	Stage 9 running time	0.0...6,000.0 s	20.0	0.1	Stop
E3.81	Stage 10 running time	0.0...6,000.0 s	20.0	0.1	Stop
E3.83	Stage 11 running time	0.0...6,000.0 s	20.0	0.1	Stop
E3.85	Stage 12 running time	0.0...6,000.0 s	20.0	0.1	Stop
E3.87	Stage 13 running time	0.0...6,000.0 s	20.0	0.1	Stop
E3.89	Stage 14 running time	0.0...6,000.0 s	20.0	0.1	Stop
E3.91	Stage 15 running time	0.0...6,000.0 s	20.0	0.1	Stop
E0.26	Acceleration time	0.1...6000.0 s	5.0	0.1	Run
E0.27	Deceleration time	0.1...6000.0 s	5.0	0.1	Run
E3.10	Acceleration time 2	0.1...6,000.0 s	10.0	0.1	Run
E3.11	Deceleration time 2	0.1...6,000.0 s	10.0	0.1	Run
E3.12	Acceleration time 3	0.1...6,000.0 s	10.0	0.1	Run
E3.13	Deceleration time 3	0.1...6,000.0 s	10.0	0.1	Run
E3.14	Acceleration time 4	0.1...6,000.0 s	10.0	0.1	Run
E3.15	Deceleration time 4	0.1...6,000.0 s	10.0	0.1	Run
E3.16	Acceleration time 5	0.1...6000.0 s	10.0	0.1	Run
E3.17	Deceleration time 5	0.1...6000.0 s	10.0	0.1	Run
E3.18	Acceleration time 6	0.1...6,000.0 s	10.0	0.1	Run
E3.19	Deceleration time 6	0.1...6,000.0 s	10.0	0.1	Run
E3.20	Acceleration time 7	0.1...6,000.0 s	10.0	0.1	Run
E3.21	Deceleration time 7	0.1...6,000.0 s	10.0	0.1	Run
E3.22	Acceleration time 8	0.1...6,000.0 s	10.0	0.1	Run
E3.23	Deceleration time 8	0.1...6,000.0 s	10.0	0.1	Run

For the stage definition, see [chapter "Adjust the setting frequency by multi-speed function"](#) on page 103.



- If a stage running time is set to 0, simple PLC skips that stage.
- 'PID control' has a higher priority than 'Simple PLC control'. To use 'Simple PLC control', deactivate 'PID control' first.

12.8.4 Stop and Pause Simple PLC Control

Active 'Simple PLC control' can be stopped or paused by configuration of X1...X5 input with functions of 'Simple PLC stop' or 'Simple PLC pause'.

Code	Name	Setting range	Default	Min.	Attri.
E1.00	X1 input	26: Simple PLC stop 27: Simple PLC pause	0	1	Stop
E1.01	X2 input		0	1	Stop
E1.02	X3 input		0	1	Stop
E1.03	X4 input		0	1	Stop
E1.04	X5 input		0	1	Stop

- 26: Simple PLC stop

The frequency converter stops output till next 'Run command' is active, and the motor freewheels to stop.

- 27: Simple PLC pause

'PLC control' is paused and the frequency converter decelerates to run at 0.00 Hz till the pause signal is inactive.

A typical simple PLC pause process is as listed in the table below:

Step	Simple PLC pause	Run command	Converter status	Description
1	Inactive	Active	Run	Simple PLC cycles with each stage
2	Active	Active	Decelerating to 0 Hz (No stop DC-braking)	Dec. time is according to current simple PLC stage setting
3	Inactive	Active	Accelerate to previous stage	Acc. Time is according to previous simple PLC stage setting before pause
4	Inactive	Inactive	Stop	Stop according to [E0.50]
5	Inactive	Active	Run	Restart from 1 st simple PLC stage

Tab. 12-17: Typical simple PLC pause process

12.8.5 Indication of Simple PLC Status

An indication signal is active via 'DO1 output' or 'Relay1 output' when a simple PLC cycle or stage is complete.

Define the output with respective indication signals as below:

Code	Name	Setting range	Default	Min.	Attri.
E2.01	DO1 output selection	7: Simple PLC stage complete	1	-	Stop
E2.15	Relay1 output selection	8: Simple PLC cycle complete	1	-	Stop

● 7: Simple PLC stage complete

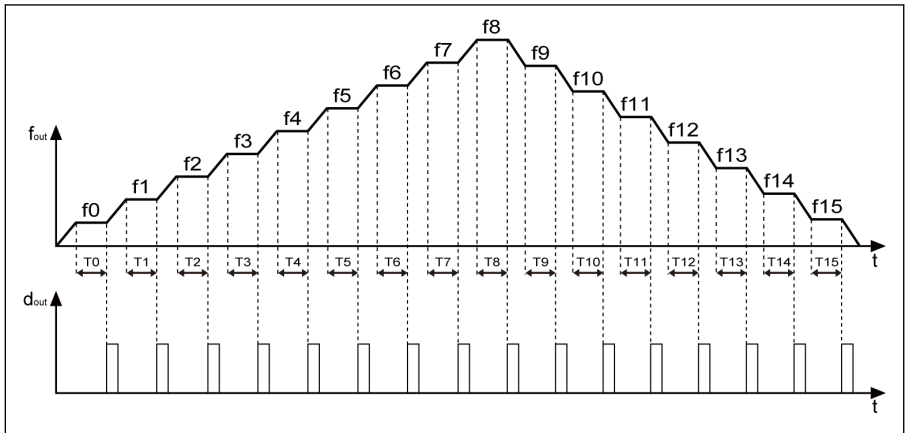

f_{out} Output frequency

d_{out} Digital output

t Time

Fig. 12-37: Simple PLC stage complete

When a stage is complete, a pulse signal is active for the duration of 0.5 s. Any stage with running time of 0.0 s will be skipped without pulse output.

- If the running time of one stage is so short that it finishes before the 'Simple PLC stage complete' signal of the previous stage is deactivated, the signal remains active and the pulse duration calculation is restarted.
- If the setting frequency of next stage is lower than that of the current stage, the frequency converter decelerates to the next stage with the deceleration time of current stage.

If the set frequency of next stage is higher than that of the current stage, the frequency converter accelerates to the next stage with the acceleration time of next stage.

● 8: Simple PLC cycle complete

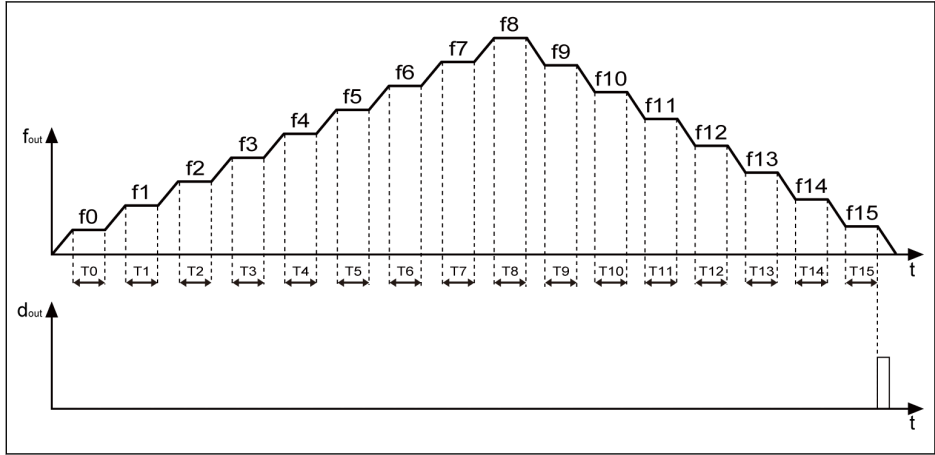

f_{out} Output frequency
 d_{out} Digital out
 t Time

Fig. 12-38: Simple PLC cycle complete

When a cycle is complete, a pulse signal is active for the duration of 0.5 s.

12.9 PID Control

12.9.1 Function Description

PID control is used in process controls such as flow control, pressure control, temperature control, and in control of other engineering values. In PID control, a negative feedback system is formed with proportional, integral and derivative operations based on the differences between reference values and their feedback. In this way, the difference between the actual output and the reference is reduced.

The basic control principle is shown as the figure below:

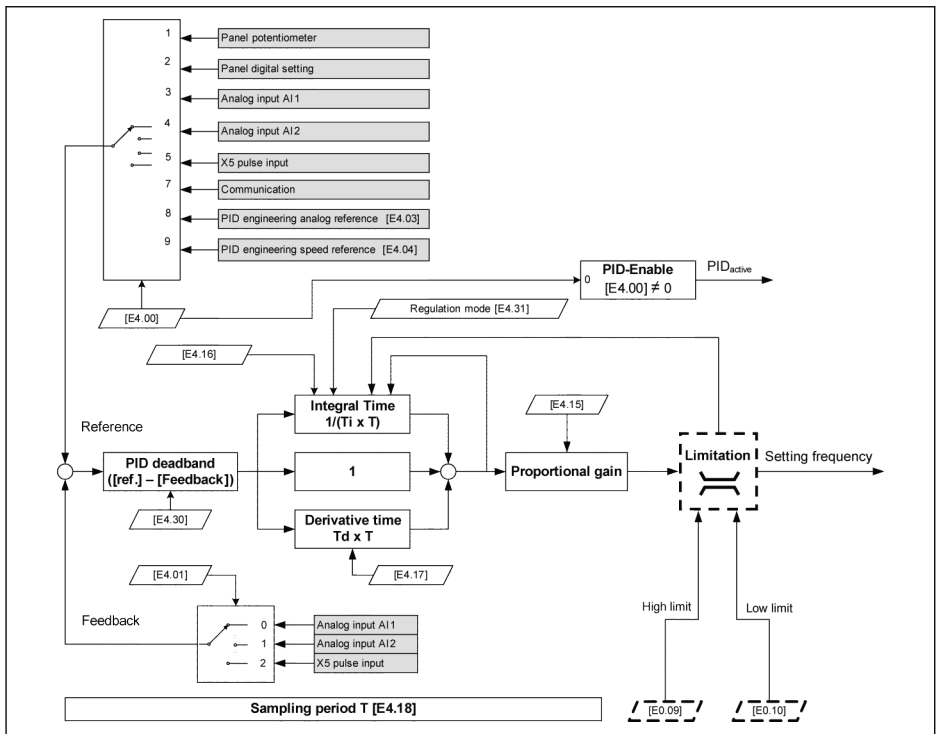

Fig. 12-39: PID control principle

12.9.2 Selecting the Reference and Feedback

Before using PID control function make sure [E4.00] ≠ '0: No PID control'.

Take the following steps to configure the PID reference:

Step 1: Select the PID reference channel

Code	Name	Setting range	Default	Min.	Attri.
E4.00	PID reference channel	0...9	0	1	Stop
E4.03	PID engineering analog reference	0.00...10.00	0.00	0.01	Run
E4.04	PID engineering speed reference	0...30,000 rpm	0	1	Run

- [E4.00] = 0: No PID control
The PID control function is inactive.
- [E4.00] = 1: Panel potentiometer
The reference value is set by adjusting the potentiometer on the operating panel.
- [E4.00] = 2: Panel button setting
The reference value is set by E0.07 'Digital setting frequency', which can be decreased or increased by pressing the <▼> or <▲> buttons on the operating panel respectively when the frequency converter is running.
- [E4.00] = 3: AI1 analog input
The reference value is set by AI1 analog input.
- [E4.00] = 4: AI2 analog input
The reference value is set by AI2 analog input.
- [E4.00] = 5: X5 pulse input
The reference value is set by pulse signal via X5 input.
- [E4.00] = 7: Communication
The reference value is set by engineering software, PLC or other external devices via Modbus or other communication.
- [E4.00] = 8: PID engineering analog reference [E4.03]
The reference value is set by parameter E4.03.
- [E4.00] = 9: PID engineering speed reference [E4.04]
The reference value is set by parameter E4.04.

Step 2: Select the PID feedback channel

Code	Name	Setting range	Default	Min.	Attri.
E4.01	PID feedback channel	0...2	0	-	Stop

- 0: AI1 analog input
Feedback value is set by AI1 analog input.

- 1: AI2 analog input
Feedback value is set by AI2 analog input.
- 2: X5 pulse input
Feedback value is set by X5 pulse input.



Any of AI1, AI2 analog inputs and X5 pulse input can **ONLY** be assigned with one function.

12.9.3 Control Loop Configuration

Code	Name	Setting range	Default	Min.	Attri.
E4.15	Proportional gain - P	0.000...10.000	1.500	0.001	Run
E4.16	Integral time - Ti	0.00...100.00 s (0.00: no integral)	0.00	0.01	Run
E4.17	Derivative time - Td	0.00...100.00 s (0.00: no derivative)	0.00	0.01	Run
E4.18	Sampling period - T	0.01...100.00 s	0.50	0.01	Run

- Proportional gain - P: Decides the gain of deviation
 - Larger P means larger scale and faster response, but excessively large P leads to oscillation.
 - P cannot eliminate deviation completely.
- Integral time - Ti: Used to eliminate the deviation
 - Smaller Ti means faster response of the frequency converter to deviation changes, but excessively small Ti leads to oscillation.
 - If Ti = 0, integration is deactivated during PID control
 - Integration stops but the integral value is kept.
 - Integration continues if Ti ≠ 0.
- Derivative time - Td: Used to respond fast to changes of deviation between reference and feedback.
 - Larger Td means faster response, but excessively large Td leads to oscillation.
 - If Td = 0, derivative is deactivated during PID control.
Derivative stops and its value is reset to '0'.
- Sampling period - T: Sampling time in PID control
The value should match with the selected time constant Ti or Td, normally shorter than 1/5 of the time constant.

12.9.4 PID Regulation Mode Setting

Code	Name	Setting range	Default	Min.	Attri.
E4.30	PID deadband	0.0...20.0%	2.0	0.1	Run

This parameter is used to set the limit of the deviation between reference and feedback value. When the difference is within the defined 'PID deadband', PID control stops to bring a stable output.

Code	Name	Setting range	Default	Min.	Attri.
E4.31	PID regulation mode	0, 1	0	-	Run

When the PID output reaches [E0.09] 'Output frequency high limit' or [E0.10] 'Output frequency low limit' in PID control, following modes are available for PID regulation:

- 0: Stop integral regulation when frequency arrives at upper / lower limit
 When the difference between the reference values and the feedback values changes, the integral value follows immediately the difference. When the setting frequency reaches the limits, the integration stops, and the integral value remains unchanged.
 This mode is used in applications with fast change reference values.
- 1: Continue integral regulation when frequency arrives at upper / lower limit
 When the PID output reaches the limits, the integral continues up to its possible numerical limit.
 This mode is used in applications with stable reference values. When the difference between reference and feedback changes, more time is needed to eliminate the impact of accumulated integral regulation before the integral value can follow the change in the trend.

12.9.5 PID Deactivation by Digital Input

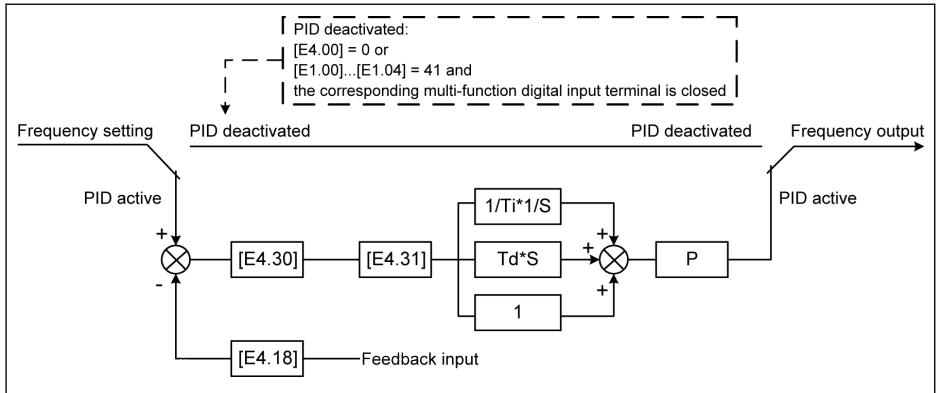

Fig. 12-40: PID deactivation by digital input

The PID control is deactivated in the following ways:

- 'PID reference channel' [E4.00] = '0: No PID control' or
- 'X1...X5 input' [E1.00]...[E1.04] = '41: PID deactivation' and respective multi-function digital input terminal is active.

12.9.6 PID Engineering Value Display

This function is used to display an engineering value which is convenient for the application engineering with scaling the output value, follow the equations below:

- User-defined setting speed:
 $[d0.04] = [d0.02] \times [E5.02]$
- User-defined output speed:
 $[d0.05] = [d0.00] \times [E5.02]$

Code	Name	Setting range	Default	Min.	Attri.
E5.02	User-defined speed scaling factor	0.01...100.00	1.00	0.01	Run
d0.01	Actual speed	-	-	1 rpm	Read
d0.03	Setting speed	-	-	1 rpm	Read
d0.04	User-defined setting speed	-	-	0.1	Read
d0.05	User-defined output speed	-	-	0.1	Read
d0.70	PID reference engineering value	-	-	0.1	Read
d0.71	PID feedback engineering value	-	-	0.1	Read

$[d0.70] = [E4.02] \times [\text{PID reference}]$

$[d0.71] = [E4.02] \times [\text{PID feedback}]$

12.9.7 PID Status Indication

Code	Name	Setting range	Default	Min.	Attri.
E4.32	PID engineering value detection width	0.01...100.00	1.00	0.01	Run
E2.01	DO1 output selection	18: PID reference engineering value arrival	1	-	Stop
E2.15	Relay1 output selection		1	-	Stop

[E4.32] 'PID engineering value detection width' is used to set the tolerance window between [d0.70] 'PID reference engineering value' and [d0.71] 'PID feedback engineering value'. When the difference between reference and feedback is within the detection width, the value arrival signal will be active via DO1 output.

$$\text{Set [E4.32]} = \frac{|[d0.70] - [d0.71]|}{[d0.70]} \times 100 \%$$

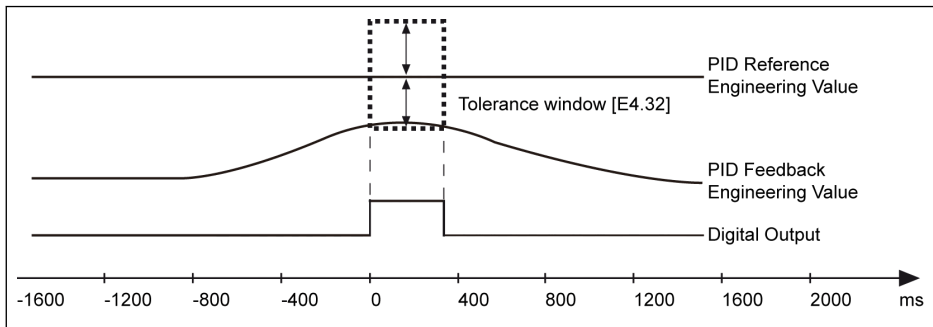

Fig. 12-41: PID engineering value detection width

12.9.8 Sleep / Wake Function

This function is used to achieve the maximum extent of energy-saving according to type of loads in actual applications.

Code	Name	Setting range	Default	Min.	Attri.
E5.15	Sleep level	0.00...[E0.09] Hz	0.00	0.01	Run
E5.16	Sleep delay	0.0...3,600.0 s	60.0	0.1	Run
E5.17	Sleep boost time	0.0...3,600.0 s	0.0	0.1	Run
E5.18	Sleep boost amplitude	0.0...100.0 %	0.0	0.1	Run
E5.19	Wake up level	0.0...100.0 %	0.0	0.1	Run
E5.20	Wake up delay	0.2...60.0 s	0.5	0.1	Run

The frequency converter may go into the sleep mode when all the conditions below are met:

- [PID feedback] > [E5.19] 'Wake up level'
- [PID output] < [E5.15] 'Sleep level'
- [Duration] $t \geq$ [E5.16] 'Sleep delay'

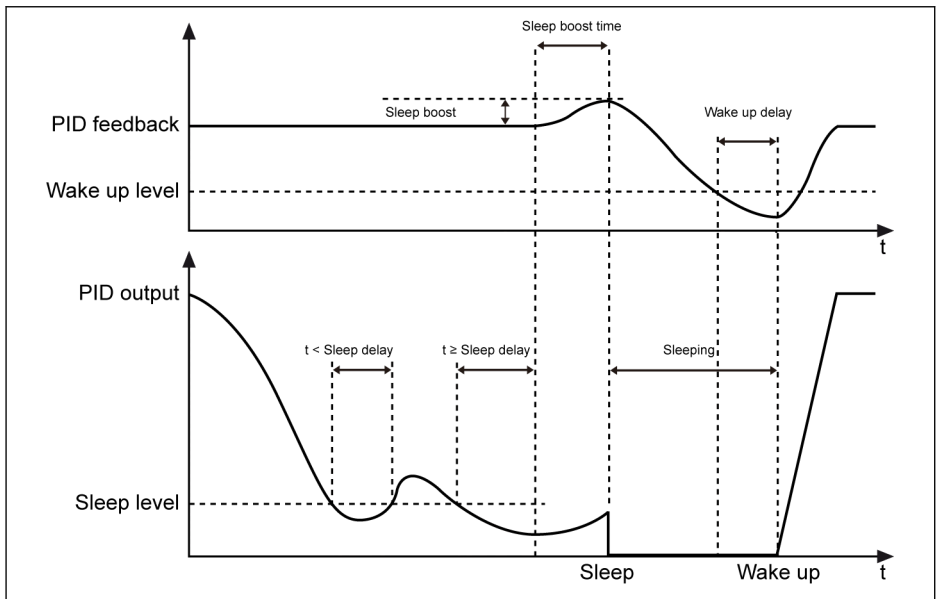

Fig. 12-42: Sleep and wake up process

After [E5.16] 'Sleep delay', the PID controller boosts up with [E5.18] 'Sleep boost amplitude' within [E5.17] 'Sleep boost time', and then enters to sleep mode. In sleep mode, the frequency converter stops output with 'PSLP' displayed on the operating panel.

[Sleep boost] = [E5.18] x [PID reference]

During sleeping, the frequency converter monitors the actual PID feedback and wakes up when the following two conditions are met:

- [PID feedback] < [E5.19] 'Wake up level'
- [Duration] t ≥ [E5.20] 'Wake up delay'

The frequency converter resumes to its previous running status after waking up.

12.9.9 Pump Protection Function

Two modes of pump protection are available:

- Pump dry protection: Protecting the pump from running without water load (e.g., water pump without water)
- Pump leakage protection: Protecting the pump from running with leakage

Both protection modes are realized by comparing the PID feedback with the PID reference when the frequency converter is running at [E0.09] 'Output frequency high limit'.

Code	Name	Setting range	Default	Min.	Attri.
E5.05	Pump dry protection ratio	0.0 %... [E5.08]	30.0	0.1	Run
E5.06	Pump dry protection delay	0.0...300.0 s (0.0 s: Inactive)	0.0	0.1	Run
E5.07	Pump dry protection delay at start-up	0.0...300.0 s	30.0	0.1	Run
E5.08	Pump leakage protection ratio	0.0...100.0 %	50.0	0.1	Run
E5.09	Pump leakage protection delay	0.0...600.0 s (0.0 s: Inactive)	0.0	0.1	Run
E5.10	Pump leakage protection delay at start-up	0.0...600.0 s	60.0	0.1	Run
E9.05	Last error type	24: Pdr, pump dry	0	1	Read
E9.06	Second last error type		0	1	Read
E9.07	Third last error type		0	1	Read

The conditions to trigger the pump dry protection:

- Frequency converter runs at the [E0.09] 'Output frequency high limit'
- $([\text{PID feedback}] \div [\text{PID reference}]) < [\text{E5.05}]$ 'Pump dry protection ratio'
- Duration \geq [E5.06] 'Pump dry protection delay'

When the pump dry protection is triggered, the error code 'Pdr' will be displayed on the operating panel. The error message '24: Pdr, pump dry' can be read via parameters E9.05...E9.07.

The conditions to trigger the pump leakage protection:

- Frequency converter runs at the [E0.09] 'Output frequency high limit'
- $([\text{PID feedback}] \div [\text{PID reference}]) < [\text{E5.08}]$ 'Pump leakage protection ratio'
- Duration \geq [E5.09] 'Pump leakage protection delay'

When the pump leakage protection is triggered, the warning code 'PLE' will be displayed on the operating panel.



- The 'Pump dry protection delay at start-up' E5.07 and the 'Pump leakage protection delay at start-up' E5.10 are used to prevent the two modes of protection at start-up process.
 - These two modes of protection are only valid when PID control is enabled.
-

12.10 Protection Functions

12.10.1 Converter Protection

Overload pre-warning

When the frequency converter output current is higher than [C0.29] 'Converter overload pre-warning level' and lasts for longer than [C0.30] 'Converter overload pre-warning delay', the 'Converter overload pre-warning' signal will be active on DO1 output or Relay1 output. The signal will be immediately inactive when the output current is lower than [C0.29].

The actual overload pre-warning level will be reduced by the output current derating by the equation:

$$[\text{Actual overload pre-warning level}] = [\text{C0.29}] \times [\text{Derating percentage}]$$

Example: When [C0.29] = 50 %, the derating percentage of the output current at 15 kHz is 51 %, as shown in [chapter "Derating and carrier frequency" on page 24](#).

- When the carrier frequency is 4 kHz, the output current is 100 % of the rated current, the actual overload pre-warning level is 50 %, which equals to the [C0.29].
- When the carrier frequency is 15 kHz, the output current is derated to 51 % of the rated current, the actual overload pre-warning level is 50 % x 51 %.

Code	Name	Setting range	Default	Min.	Attri.
C0.29	Converter overload pre-warning level	20.0...200.0 %	110.0	0.1	Stop
C0.30	Converter overload pre-warning delay	0.0...20.0 s	2.0	0.1	Stop
E2.01	DO1 output selection	11: Converter overload pre-warning	1	-	Stop
E2.15	Relay1 output selection		1	-	Stop

Stall overvoltage prevention

This function is used to prevent the frequency converter from overvoltage during deceleration when the load is excessively heavy or the deceleration time is excessively short.

Code	Name	Setting range	Default	Min.	Attri.
C0.25	Overvoltage prevention mode	1: Stall overvoltage protection enabled, resistor braking disabled	0	-	Stop
C0.26	Stall overvoltage prevention level	1P 200 VAC: 300...390 V 3P 400 VAC: 600...785 V	390 770	0	Stop

With stall overvoltage prevention, the frequency converter detects the DC-bus voltage and compares it with [C0.26] 'Stall overvoltage prevention level' during deceleration:

- [DC-bus voltage] > [C0.26]: The output frequency stops decreasing
- [DC-bus voltage] < [C0.26]: The output frequency resumes decreasing

The typical behavior of stall overvoltage prevention is shown as the figure below:

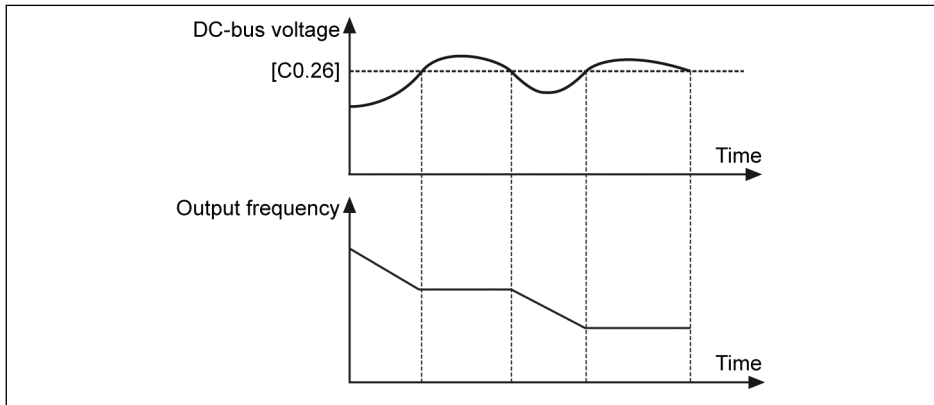

Fig. 12-43: Stall overvoltage prevention during deceleration



If [C0.26] is too low, the deceleration process may fail.

Stall overcurrent prevention

This function is used to prevent the frequency converter from overcurrent when the load is excessively heavy or the acceleration time is excessively short. This function is always active during acceleration or at constant speed.

Code	Name	Setting range	Default	Min.	Attri.
C0.27	Stall overcurrent prevention level	20.0 %...[C2.42]	200.0	0.1	Stop

The typical behavior of stall overcurrent during acceleration is shown as the figure below:

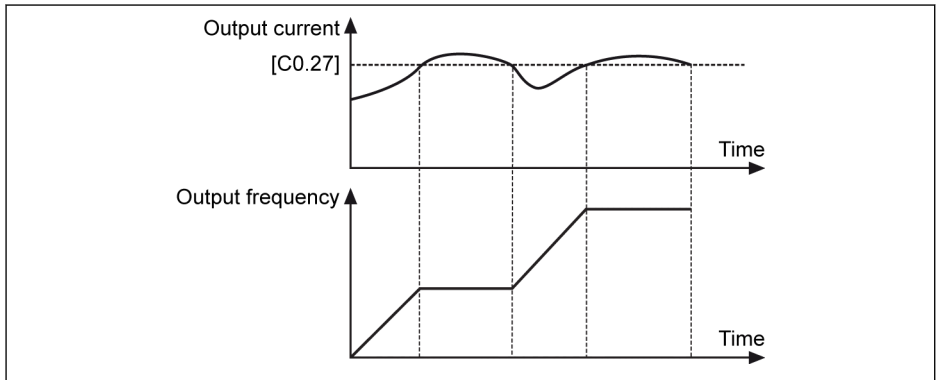

Fig. 12-44: Stall overcurrent during acceleration

- [Output current] > [C0.27]
The output frequency stops increasing.
- [Output current] < [C0.27]
The output frequency resumes increasing to the setting frequency with defined acceleration time.

The typical behavior of stall overcurrent at constant speed is shown as the figure below:

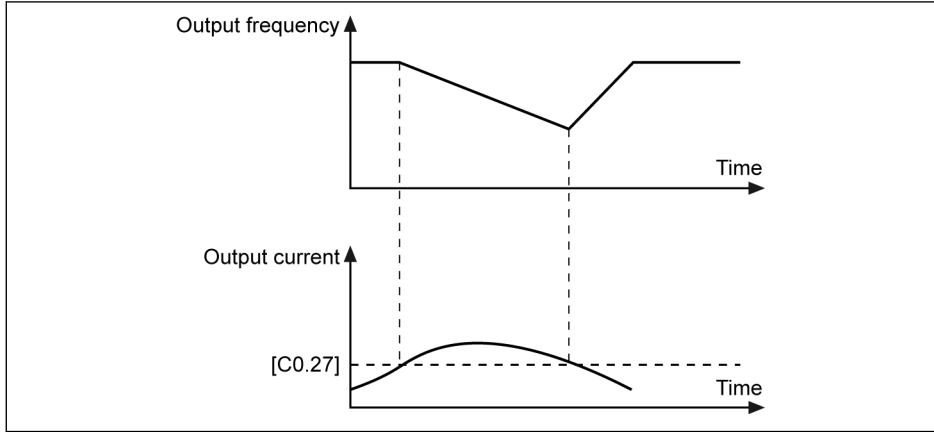

Fig. 12-45: Stall overcurrent at constant speed

- [Output current] > [C0.27]
The output frequency decreases till the output current is lower than [C0.27] with defined deceleration time.
- [Output current] < [C0.27]
The output frequency increases to the setting frequency with defined acceleration time.

Phase loss protection

Error code 'IPH.L' is displayed on the operating panel in case of input phase loss error occurs; error code 'OPH.L' is displayed on the operating panel in case of output phase loss error occurs.

Code	Name	Setting range	Default	Min.	Attri.
C0.28	Phase loss protection mode	0...3	3	-	Run

- 0: Both input and output phase loss protection active
- 1: Only input phase loss protection active
- 2: Only output phase loss protection active
- 3: Both input and output phase loss protection inactive

An input phase loss can also be triggered by line voltage imbalance or deterioration of DC-bus capacitors. The input phase loss cannot be detected in the following conditions:

- No run command
- The output current is lower than 30 % of converter rated current
- During motor deceleration

The output phase loss has a dead zone in the following cases:

- The output frequency is lower than 1.00 Hz
- During DC-braking
- During restarting with speed capture
- During motor parameters auto-tuning
- Wrong settings of parameter C1.07 'Motor rated current'

Analog Input Broken Wire Detection

Code	Name	Setting range	Default	Min.	Attri.
E1.61	Broken wire reaction mode	0: Inactive 1: Warning 2: Error	0	-	Stop

If '4...20 mA' or '2...10 V' is selected for AI1 and AI2 analog input, then this function can detect the input missing possibly due to the cable disconnection. Once the broken wire is detected, the frequency converter can either continue running with warning (Warning code: Aib-) or stop with error indication (Error code: AibE), which can be configured by parameter E1.61.

For 4...20 mA analog input, the detection level is 10 % of 4 mA.

For 2...10 V analog input, the detection level is 7.5 % of 2 V.

12.10.2 Reaction to External Error Signals

The frequency converter stops once an external error signal is active and the error code 'E-St' will be displayed on the operating panel if one X1...X4 input is defined as either 'Error signal N.O. contact input' or 'Error signal N.C. contact input'.

Code	Name	Setting range	Default	Min.	Attri.
E1.00	X1 input	32: Error signal N.O. contact input 33: Error signal N.C. contact input	0	1	Stop
E1.01	X2 input		0	1	Stop
E1.02	X3 input		0	1	Stop
E1.03	X4 input		0	1	Stop
E1.04	X5 input		0	1	Stop

- 32: Error signal N.O. contact input
 - If the defined switch is closed, the external error signal is active.
 - If the defined switch is open, the external error signal is inactive.
- 33: Error signal N.C. contact input
 - If the defined switch is open, the external error signal is active.
 - If the defined switch is closed, the external error signal is inactive.

Example:

Set [E1.00] = '32: Error signal N.O. contact input'

or

Set [E1.01] = '33: Error signal N.C. contact input'

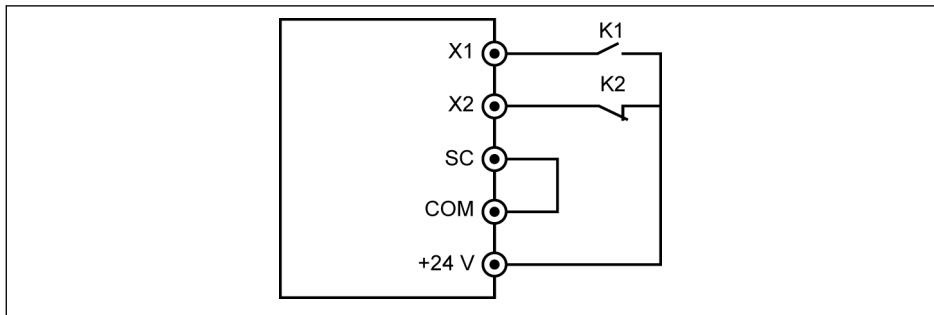

Fig. 12-46: Error signal

The frequency converter stops and indicates error code 'E-St' if K1 is closed.

or

The frequency converter stops and indicates error code 'E-St' if K2 is open.

12.10.3 Motor Protection

Motor derating frequency at low speed

This function is used to reduce the overload and thermal risks as motors have worse cooling performance at low speed, compared at rated speed.

Code	Name	Setting range	Default	Min.	Attri.
C1.75	Low speed derating frequency	0.10...300.00	25.00	0.01	Run
C1.76	Zero speed load	25.0...100.0 %	25.0	0.1	Run

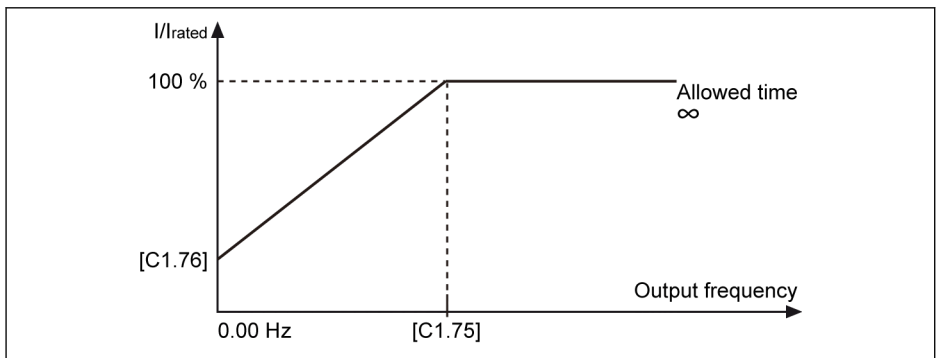

Fig. 12-47: Derating at low speed

- Low speed derating frequency

When the output frequency is higher than [C1.75] 'Low speed derating frequency', the allowed continuous current is [C1.07] 'Motor rated current'.

When the output frequency is lower than [C1.75], the allowed continuous current is reduced according to the above curve, with the lowest value to [C1.76] 'Zero speed load' at standstill.

- Zero speed load

Zero speed load is the allowed continuous current (percentage of rated current) at standstill.



For a motor with external cooling, [C1.76] 'Zero speed load' is set to 100 %, and the low speed derating function is inactive.

Motor thermal protection without temperature sensor

This function is to realize the motor thermal protection based on the thermal model of motor.

Code	Name	Setting range	Default	Min.	Attri.
C1.69	Motor thermal model protection setting	0: Inactive 1: Active	1	-	Stop
C1.74	Motor thermal protection time constant	0.0...400.0 min	DOM	0.1	Stop

[C1.74] is obtained by the equation below:

$$[C1.74] = \frac{C_v * M}{9 * [C1.21] * [C1.07]^2}$$

Cv: Specific heat capacity (J/kg)
Cv of iron (Fe): 450 J/kg
Cv of aluminium (Al): 900 J/kg
M: Motor weight (kg)

Fig. 12-48: Motor thermal protection time constant

Increase the value of C1.74 'Motor thermal protection time constant' appropriately if motor overload protection error code 'OL-2' occurs frequently. This function can be disabled by setting [C1.69] = 0, if necessary.

Ensure that the converter output current does not exceed 110 % of the [C1.07] 'Motor rated current'.

Motor overload pre-warning

Code	Name	Setting range	Default	Min.	Attri.
C1.70	Motor overload pre-warning level	100.0...250.0 %	100.0	0.1	Run
C1.71	Motor overload pre-warning delay	0.0...20.0	2.0	0.1	Run
E2.01	DO1 output selection	12: Motor overload pre-warning	1	-	Stop
E2.15	Relay1 output selection		1	-	Stop

When the output current exceeds the threshold defined by C1.70 'Motor overload pre-warning level' for [C1.71] 'Motor overload pre-warning delay', the pre-warning signal is active on DO1 or Relay1 output. Users may use the indication of this pre-warning signal according to actual application situations. The signal is immediately deactivated when the output current is lower than the threshold.

Motor thermal protection with temperature sensor

For a temperature sensor with voltage supply, use terminals +10 V, AI1 / AI2 and GND on the frequency converter.

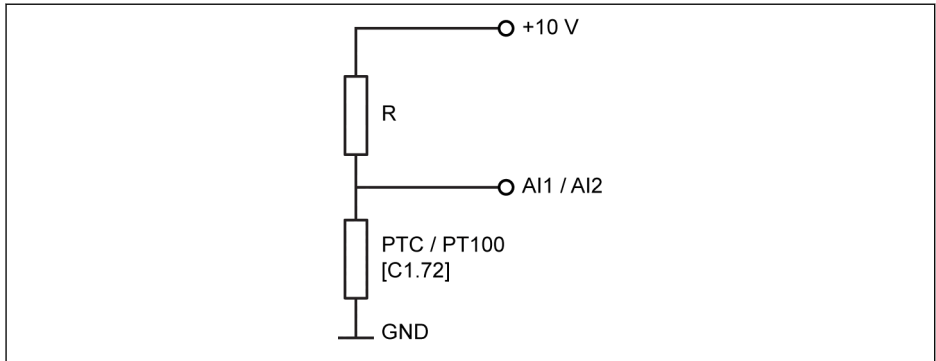

Fig. 12-49: Temperature sensor with voltage supply

For a temperature sensor with current supply, use terminals AO1, AI1 / AI2 and GND on the frequency converter.

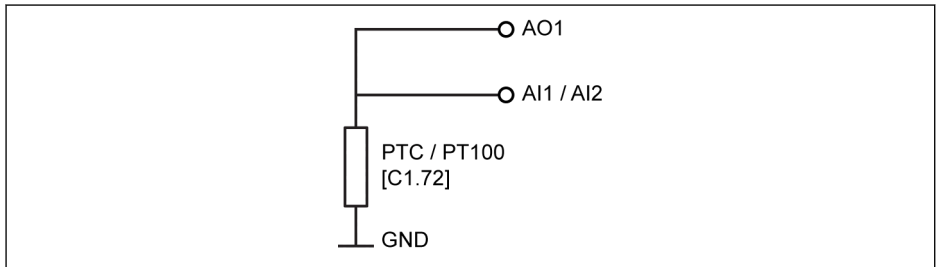

Fig. 12-50: Temperature sensor with current supply

Code	Name	Setting range	Default	Min.	Attri.
E1.60	Motor temperature sensor channel	0...2 (0: Inactive)	0	-	Stop
C1.72	Motor sensor type	0, 2	0	-	Stop
E1.35	AI1 input mode	0: 0...20 mA	2	-	Run
E1.40	AI2 input mode	1: 4...20 mA 2: 0...10 V 3: 0...5 V 4: 2...10 V	1	-	Run
E2.25	AO1 output mode	0: 0...10 V 1: 0...20 mA	0	-	Run

Code	Name	Setting range	Default	Min.	Attri.
E2.26	AO1 output selection	11: Motor temperature sensor power	0	-	Run
C1.73	Motor protection level	0.0...10.0	2.0	0.1	Stop
C1.74	Motor thermal protection time constant	0.0...400.0 min	DOM	0.1	Stop
E1.69	Analog channel filter time	0.000...2.000 s	0.100	0.001	Run

Activate the function of temperature monitoring with temperature sensor:

- Set [E1.60] = '1: AI1 analog input' or
- Set [E1.60] = '2: AI2 analog input'



AI1 / AI2 will be automatically set as voltage input mode when [E1.60] = 1 or 2.

Select the sensor type:

- [C1.72] = 0: PTC

For PTC sensors, the value of resistor R in the figure should be close to the sensor resistance when the motor is at high temperature.

- [C1.72] = 2: PT100

For a good resolution of temperature with PT100 sensors, the value of resistor R in the figure should be close to the sensor resistance at the motor temperature limit.

Supply source to the temperature sensor:

- If [E2.26] = '11: Motor temperature sensor power', AO1 is shifted with current supply mode regardless of the setting of E2.25. In this case, AO1 output current is:
 - [C1.72] = 0, AO1 output = 1.6 mA, or
 - [C1.72] = 2, AO1 output = 9.1 mA
- If [E2.26] ≠ 11, AI1 output mode is resumed to [E2.25] 'AO1 output mode' automatically.

Set the motor protection level

Set C1.73 'motor protection level' according to the characteristic of the temperature sensor. The setting value corresponds to the voltage value detected by of AI1 / AI2 input.

Example: If [C1.73] = 2, it represents 2 V, and the frequency converter stops with error code 'Ot' displayed on the operating panel when the voltage level on AI1 / AI2 is higher than 2 V.



If AI1 and AI2 analog inputs have been defined with other functions, E1.60 cannot be set to 1 or 2.

12.10.4 Resistor Braking Test

This function is used to test the status of the brake chopper and brake resistor when the frequency converter is in stop state.

Code	Name	Setting range	Default	Min.	Attri.
C0.17	Braking testing	0: Inactive; 1: Active	0	-	Stop

- 0: Inactive

This parameter is inactive by default and automatically reset to be inactive after the brake testing process.

- 1: Active

Following pre-conditions need to be met for this function:

- The frequency converter is in stop state.
- The soft start relay must be closed for a successful soft start. Otherwise, the setting will be reset directly to be inactive.
- The DC-bus voltage must be higher than the undervoltage threshold. If the DC-bus voltage drops below the threshold, the braking test will be stopped immediately and [C0.17] will be reset to inactive.

	1P 200 VAC	3P 400 VAC
DC-bus undervoltage threshold [V]	230	420
Hysteresis voltage [V]	24	10

A typical braking testing process is as shown in the figure below:

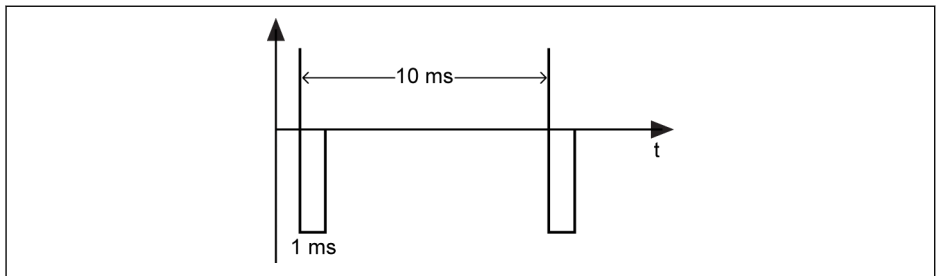

Braking testing time 10 ms

Braking duty cycle 1 ms

Fig. 12-51: Braking test process

12.10.5 Power Fault Ride-through Setting

Code	Name	Setting range	Default	Min.	Attri.
C0.40	Power fault ride-through setting	0: Inactive 1: Output disabled	0	-	Stop

When AC power is lost or not stable for a short time, the frequency converter remains active as long as the power is available (1P: DC-bus voltage above 180 V; 3P: DC-bus voltage above 370 V). In this process, the frequency converter output will be switched off. When the power supply resumes, the frequency converter will execute speed capture and resume its previous operation.

12.11 Motor Control

12.11.1 Motor Parameterization

Nameplate parameters configuration

Most of motor data are available on the motor nameplate, based on which the following parameters of the frequency converter need to be set accordingly.

Code	Name	Setting range	Default	Min.	Attri.
C1.05	Motor rated power	0.1...1000.0 kW	DOM	0.1	Stop
C1.06	Motor rated voltage	0...480 V	DOM	1	Stop
C1.07	Motor rated current	0.01...655.00 A	DOM	0.01	Stop
C1.08	Motor rated frequency	5.00...400.00 Hz	50.00	0.01	Stop
C1.09	Motor rated speed	1...30,000	DOM	1	Stop
C1.10	Motor rated power factor	0.00: Automatically identified 0.01...0.99: Power factor setting	0.00	0.00	Stop

If the data for 'Motor rated power factor' C1.10 is not available on the motor nameplate, keep its default setting '0.00: Automatically identified'. However, the rotational auto-tuning performance may be affected.

Motor slip frequency configuration

This function is available in both V/f control and SVC control, used to compensate the deviation between the motor speed and the synchronous speed caused by the load. In addition, the mechanical performance of the motor can be improved with this function.

For V/f control, slip compensation does not work in acceleration, deceleration, DC-braking processes or regenerative mode.

For SVC control, slip compensation is always active.

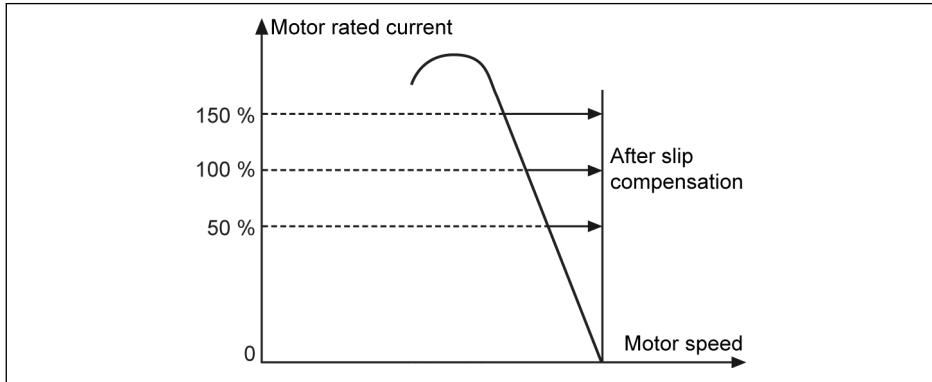

Fig. 12-52: Slip frequency compensation



If the slip frequency compensation is excessively large, the motor speed may exceed the synchronous speed.

Code	Name	Setting range	Default	Min.	Attri.
C1.12	Motor rated slip frequency	0.00...20.00 Hz	DOM	0.01	Run

By default, this parameter will be set automatically according to the basic motor parameters. The value can be adjusted with the following equations:

- $n_s = f_n \times 60 / p$
- $s = (n_s - n_n) / n_s$
- $f_s = s \times f_n$

n_s : synchronous speed; f_n : rated frequency

p : numbers of pole pairs; s : rated slip

n_n : rated speed; f_s : rated slip frequency

Motor parameter auto-tuning

Function description

With the configuration of motor nameplate parameters and motor rated slip frequency, the frequency converter can run in V/f control. In addition, the following parameters are calculated automatically based on the motor nameplate parameters:

Code	Name	Setting range	Default	Min.	Attri.
C1.20	Motor no-load current	0.00...[C1.07] A	DOM	0.01	Stop
C1.21	Stator resistance	0.00...50.00 Ω	DOM	0.01	Stop
C1.22	Rotor resistance	0.00...50.00 Ω	DOM	0.01	Stop
C1.23	Leakage inductance	0.00...200.00 mH	DOM	0.01	Stop
C1.24	Mutual inductance	0.0...3,000.0 mH	DOM	0.1	Stop

For SVC control and applications with higher performance requirement in V/f control, motor parameter auto-tuning is necessary. Two modes of auto-tuning are available, static auto-tuning and rotational auto-tuning. The former mode is mainly used for V/f control and the latter is used **ONLY** for SVC control.

The actual no-load current is limited to 75 % of the motor rated current.

Example

[C1.07] = 2.06, then set [C1.20] = 2.06, the actual setting value is 1.54.

[C1.07] = 655.00, then set [C1.20] = 655.00, the actual setting value is 491.22.

Check and make sure the following points before auto-tuning:

- The motor is in standstill and not at high temperature.
- The power rating of the frequency converter is close to that of the motor.
- Set C1.05...C1.10 based on motor nameplate data. If the power factor data is unavailable on the nameplate, keep the default setting of C1.10.
- Set E0.08 according to motor parameters and actual application conditions.



Disconnect the load from the motor shaft for rotational auto-tuning.

Set auto-tuning mode and start motor parameter auto-tuning

Set the following parameter according to the control mode of the frequency converter and the application situation:

Code	Name	Setting range	Default	Min.	Attri.
C1.01	Motor parameter tuning	0...2	0	-	Stop

- 0: Inactive. SVC control can still be used, but with lower performance.
- 1: Static auto-tuning. This mode is suggested to be used for V/f control. It can also be used for SVC control when the load cannot be disconnected.
- 2: Rotational auto-tuning (suggested to be used for SVC control)

Press the **<Run>** button on the operating panel to start auto-tuning. In the process of auto-tuning, a status code 'tUnE' will be displayed on the operating panel. When the auto-tuning process is complete, the status code disappears and the settings of the following parameters will be obtained automatically:

Static auto-tuning	Rotational auto-tuning	Parameters obtained by auto-tuning
√	√	C1.12: Motor rated slip frequency
√	√	C1.20: Motor no-load current
√	√	C1.21: Stator resistance
√	√	C1.22: Rotor resistance
√	√	C1.23: Leakage inductance
√	√	C1.24: Mutual inductance
√	√	C3.05: Current loop proportional gain
√	√	C3.06: Current loop integral time
-	√	C3.00: Speed loop proportional gain
-	√	C3.01: Speed loop integral time

Tab. 12-18: Parameters obtained by auto-tuning

12.11.2 EFC 3610 - V/f Control

V/f curve selection

Code	Name	Setting range	Default	Min.	Attri.
C2.00	V/f curve mode	0...2	0	-	Stop

The frequency converter provides three curve modes:

- 0: Linear mode

This mode refers to linear voltage / frequency control, which is used for normal constant torque loads.

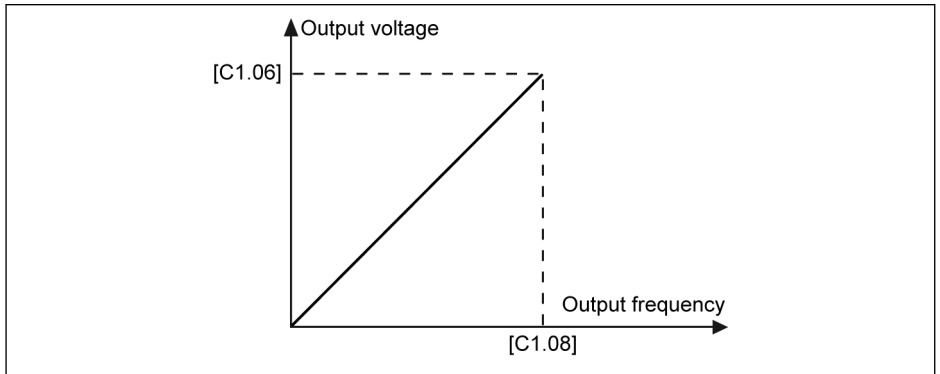

Fig. 12-53: Linear V/f curve

- 1: Square curve

This mode refers to square voltage / frequency control, which is used for variable torque loads of fans, pumps, etc.

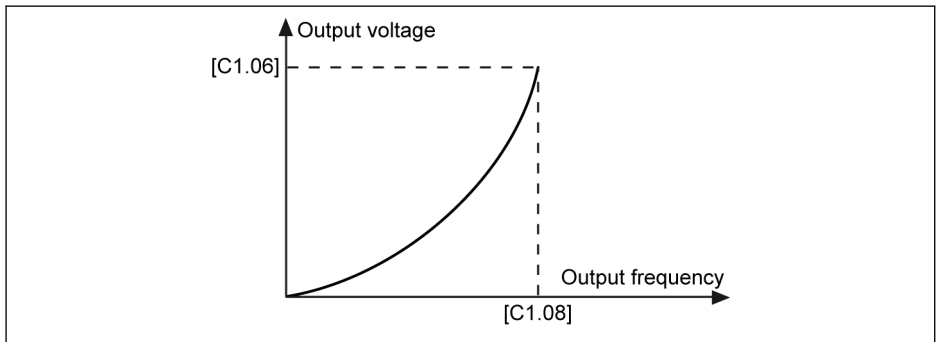

Fig. 12-54: Square V/f curve

- 2: User-defined curve

This mode refers to voltage / frequency control with curve defined according to actual application, which is used for special loads of dewatering machines, centrifuges, etc.

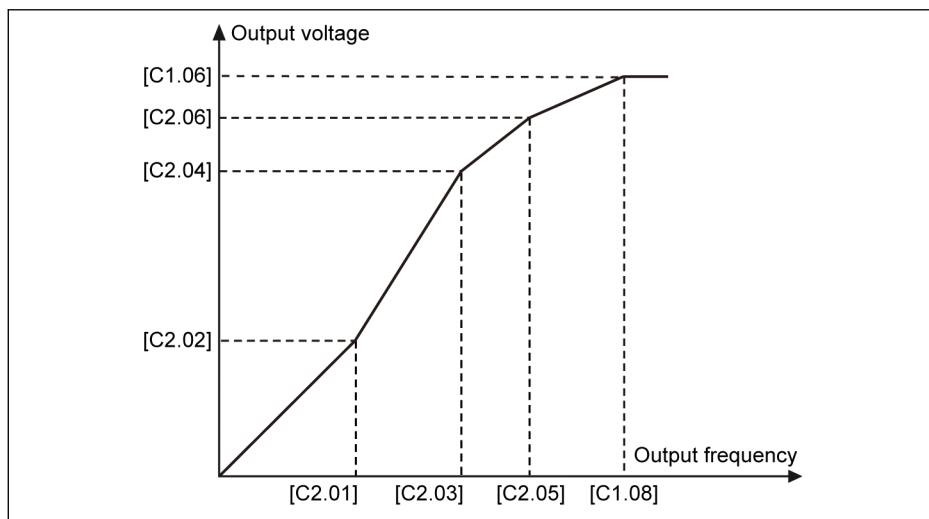

Fig. 12-55: User-defined V/f curve

⚠ WARNING

Excessively high voltage at low-frequency may cause the motor overheat or damage, and the frequency converter stall overcurrent or overcurrent protection.

User-defined V/f curve configuration

Code	Name	Setting range	Default	Min.	Attri.
C2.01	V/f frequency 1	0.00...[C2.03] Hz	0.00	0.01	Stop
C2.02	V/f voltage 1	0.0...120.0 %	0.0	0.1	Stop
C2.03	V/f frequency 2	[C2.01]...[C2.05] Hz	0.00	0.01	Stop
C2.04	V/f voltage 2	0.0...120.0 %	0.0	0.1	Stop
C2.05	V/f frequency 3	[C2.03]...[E0.08] Hz	0.00	0.01	Stop
C2.06	V/f voltage 3	0.0...120.0 %	0.0	0.1	Stop

Each of the three V/f frequency points is limited by the neighboring V/f frequency points, each V/f frequency point must be set according to following sequence: $0 \leq [C2.01] \leq [C2.03] \leq [C2.05] \leq [C1.08]$

There are two modes of user-defined V/f curve:

- User-defined V/f curve when $[C2.05] \leq [C1.08]$

In this mode, the output voltage is limited to 100 % even if [C2.06] 'V/f voltage 3' is higher than 100 %.

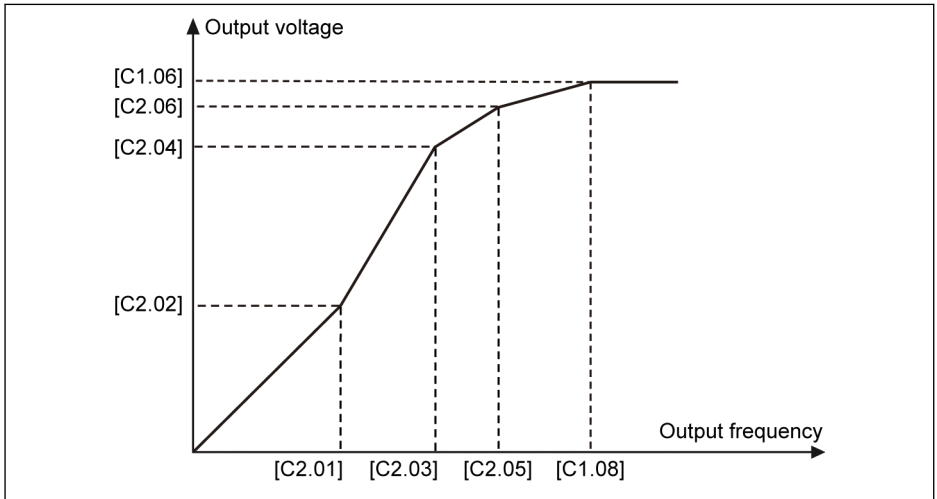

Fig. 12-56: User-defined V/f curve when $[C2.05] \leq [C1.08]$

- User-defined V/f curve when $[C2.05] \geq [C1.08]$

In field weakening range, output voltage needs to be higher than the rated voltage. In this case,

- The maximum value of C2.05 'V/f frequency 3' can be higher than [C1.08] 'Motor rated frequency'.
- The maximum value of C2.06 'V/f voltage 3' can be higher than 100 %.

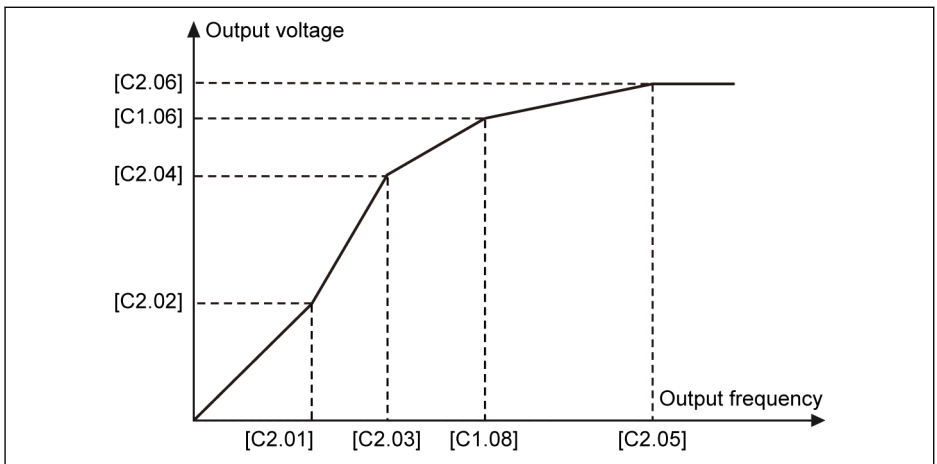

Fig. 12-57: User-defined V/f curve when $[C2.05] \geq [C1.08]$

Slip compensation factor configuration

This function is used to compensate [C1.12] 'Motor rated slip compensation' according to the actual applications in V/f control.

Code	Name	Setting range	Default	Min.	Attri.
C2.07	Slip compensation factor	0...200 %	0	1	Run

- 0 %: No slip compensation
The slip compensation function is deactivated.
- 1...100 %: Full slip compensation
Example: [C1.12] = 2.50 Hz, [C2.07] = 100 %
The actual slip compensation is 2.50 Hz x 100 % = 2.50 Hz.
- 101...200 %: Over slip compensation
Example: [C1.12] = 2.50 Hz, [C2.07] = 200 %
The actual slip compensation is 2.50 Hz x 200 % = 5.00 Hz.

Torque boost setting

The torque boost function is used to obtain higher output torque and better stabilization by boosting the output voltage, especially at low speed.

Code	Name	Setting range	Default	Min.	Attri.
C2.21	Torque boost setting	0.0 %: Automatic boost 0.1... 20.0 %: Manual boost	0.0	0.1	Run
C2.22	Torque boost factor	0...320 %	50	1	Run
C2.00	V/f curve mode	0: Linear mode 1: Square curve 2: User-defined curve	0	-	Stop
C1.08	Motor rated frequency	5.00...400.00 Hz	50.00	0.01	Stop

- Manual torque boost with linear or user-defined V/f curve

In this V/f curve, the output voltage starts to be boosted when the output frequency is lower than half of [C1.08].

Example: If [C1.08] = 50.00 Hz, then torque boost function is active when output frequency is lower than 25.00 Hz.

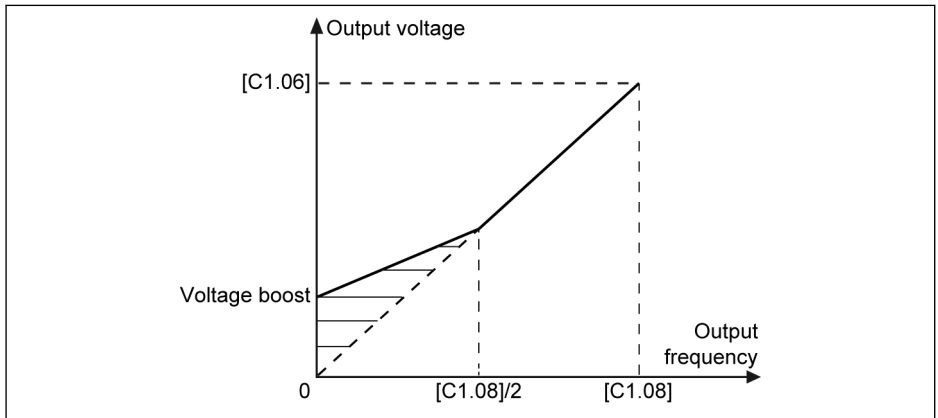

Fig. 12-58: Manual torque boost with linear or user-defined V/f curve

[C2.21] is the voltage boost value at 0.00 Hz. The actual voltage boost values for other frequency points decreases in linear along with output frequency increase.

- Manual torque boost with square curve

In this square V/f curve, the output voltage starts to be boosted when the output frequency is lower than [C1.08].

Example: If [C1.08] = 50.00 Hz, then torque boost function is active when the output frequency is lower than 50.00 Hz.

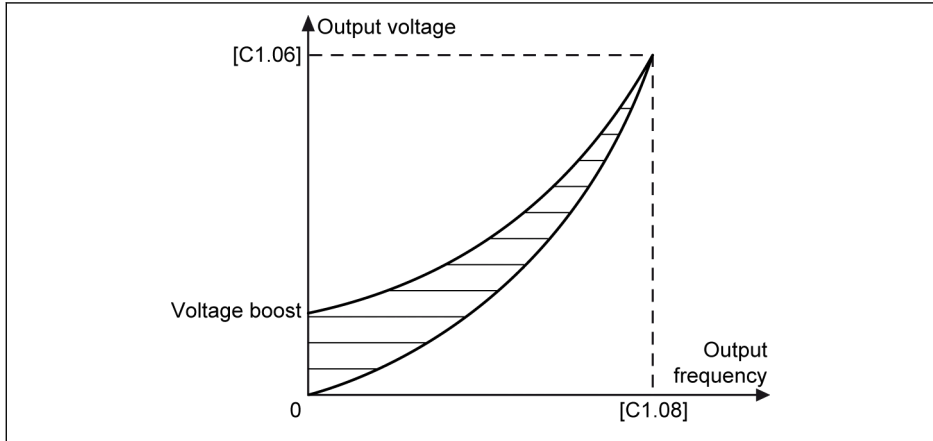

Fig. 12-59: Manual torque boost with square curve

In automatic boost mode, the output voltage boost percentage is determined automatically by the output frequency and the load current. The linear and square V/f curves for automatic torque boost are shown as figures below.

- Automatic torque boost with linear V/f curve

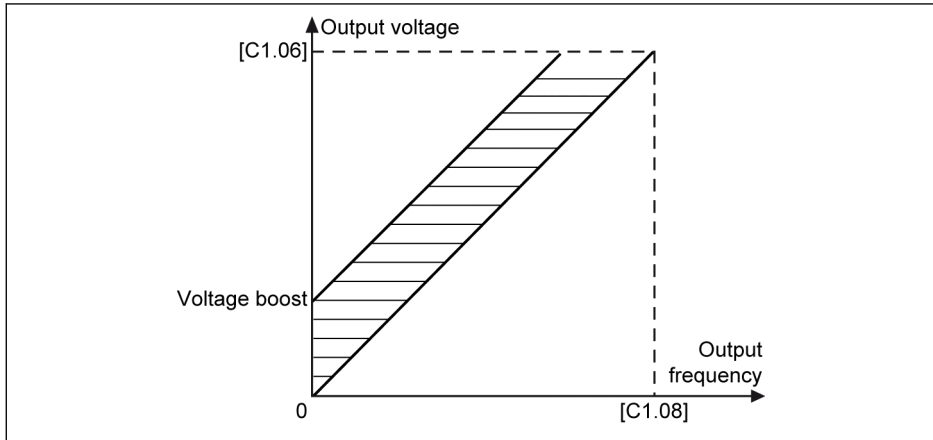

Fig. 12-60: Automatic torque boost with linear V/f curve

- Automatic torque boost with square V/f curve

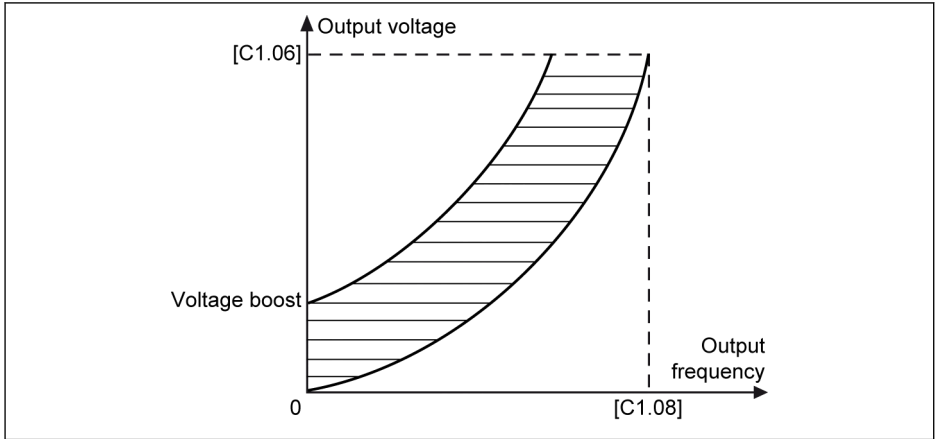

Fig. 12-61: Automatic torque boost with square V/f curve

For further adjustment of the voltage boost, set parameter C2.22 'Torque boost factor'. Its default value 50 % means no adjustment. The calculation equation is shown as below:

$$[\text{Voltage boost}] = \sqrt{3} \times 0.5 \times I_1 \times R_1 \times [\text{C2.22}]$$

R_1 : stator resistance

I_1 : stator current

Thus R_1 should be preset or calculated or tuned, and then input to [C1.21].

Optimization functions for V/f control

Heavy load voltage stabilization

This function is used to suppress the output voltage and current oscillation caused by large impact to DC-bus voltage in case of heavy load.

Code	Name	Setting range	Default	Min.	Attri.
C2.23	Heavy load stabilization	0: Inactive 1: Active	1	-	Run

Light load oscillation damping

This function is used to suppress the motor oscillation in the case of light load or no load.

Code	Name	Setting range	Default	Min.	Attri.
C2.24	Light load oscillation damping factor	0...5,000 %	0	1	Run
C2.25	Light load oscillation damping filter factor	10...2,000 %	100	1	Run

- [C2.24] = 0 %: Oscillation suppression is inactive.
- Increasing [C2.24] brings a better effect of oscillation suppression, but excessive increase leads to unstable running of the motor.
- [C2.25] = 100 %: This setting can suppress oscillation in most situations.
- Adjustment of [C2.25] is helpful in the following conditions:
 - Increase [C2.25] if the oscillation damping performance is not obvious, but excessive increase leads to slow suppression.
 - Decrease [C2.25] if the oscillation occurs at low speed.

Output current limitation

This function is used to avoid the tripping caused by over current when the load has large inertia or sudden changes.

Code	Name	Setting range	Default	Min.	Attri.
C2.40	Current limitation mode	0...2	0	–	Stop

- 0: Always inactive
Current limitation control function is inactive.
- 1: Inactive at constant speed
Current limitation control is active during acceleration and deceleration, but inactive at constant speed.
- 2: Active at constant speed
Current limitation control is active during acceleration, deceleration and at constant speed.

The current regulator is a PI regulator with configurable **P** factor and **I** factor.

- The higher value of C2.43 'Proportional gain', the faster the current suppression.
- The higher value of C2.44 'Integral time', the more accurate of current suppression.

Code	Name	Setting range	Default	Min.	Attri.
C2.42	Current limitation level	20...250 %	200	1	Stop
C2.43	Current limitation proportional gain	0.000...10.000	DOM	0.001	Stop
C2.44	Current limitation integral time	0.000...1.000	DOM	0.001	Stop

The default settings of C2.43 and C2.44 can meet requirements in most applications. If slight adjustment is necessary, increase [C2.43] first with no oscillation, and then decrease [C2.44] to achieve fast response without overshooting.

[C0.27] 'Stall overcurrent prevention level' should be smaller than [C2.42] 'Automatic current limitation level', otherwise a warning code 'PrSE' will be displayed on the operating panel and parameter setting can not be saved.

12.11.3 EFC 5610 - SVC Control

SVC control loop configuration

Code	Name	Setting range	Default	Min.	Attri.
C3.00	Speed loop proportional gain	0.00...655.35	DOM	0.01	Run
C3.01	Speed loop integral time	0.01...655.35	DOM	0.01	Run
C3.05	Current loop proportional gain	0.1...1,000.0	DOM	0.1	Run
C3.06	Current loop integral time	0.01...655.35	DOM	0.01	Run
C3.20	Low speed torque limitation factor	1...200 %	100	1	Stop

Speed control mode

The frequency converter is by default running in speed control mode. In this mode, the frequency converter follows the frequency reference change, and the output torque changes with the load.

Code	Name	Setting range	Default	Min.	Attri.
C3.44	Torque positive limit	0.0...200.0 %	150.0	0.1	Run
C3.45	Torque negative limit	0.0...200.0 %	150.0	0.1	Run

C3.44 'Torque positive limit' and C3.45 'Torque negative limit' are used to limit the output torque in speed control mode. The former parameter is used when the frequency converter is in forward running, while the latter parameter is used when it is in reverse running.

Torque control mode

When torque control mode is active, the frequency converter follows the torque reference change. In torque control mode:

- The motor speed is limited by [E0.09] 'Output frequency high limit'.
- The torque reference is set by the selected channel with defined curve characteristic.
- The direction of the torque reference is set by the selected run command source.

To use the torque control mode, take the following steps:

Step 1: Set the activation mode of torque control

Code	Name	Setting range	Default	Min.	Attri.
C3.40	Torque control mode	0: Activated by X1...X5 1: Always active	0	0	Stop
E1.00	X1 input	23: Torque / speed control switch	0	1	Stop
E1.01	X2 input		0	1	Stop
E1.02	X3 input		0	1	Stop
E1.03	X4 input		0	1	Stop
E1.04	X5 input		0	1	Stop

- [C3.40] = '0: Activate torque control by X1...X5'

In this mode, the corresponding parameter [E1.00]...[E1.04] of the selected X1...X5 input needs to be set as '23: Torque / speed control switch'.

- [C3.40] = '1: Always active'

Step 2: Set the torque reference

Code	Name	Setting range	Default	Min.	Attri.
C3.41	Torque control reference	0: AI1 1: AI2 2: Panel potentiometer	0	1	Stop
C3.42	Torque reference minimum value	0.0 %...[C3.43]	0.0	0.1	Run
C3.43	Torque reference maximum value	[C3.42]...200.0 %	150.0	0.1	Run

Define the voltage / current mode for AI1 and AI2 analog inputs before setting the torque reference.

- Parameter C3.41 'Torque control reference' is used to set torque reference channel.
- Parameters C3.42 'Torque reference minimum value' and C3.43 'Torque reference maximum value' are used to define the curve characteristic for the torque reference.

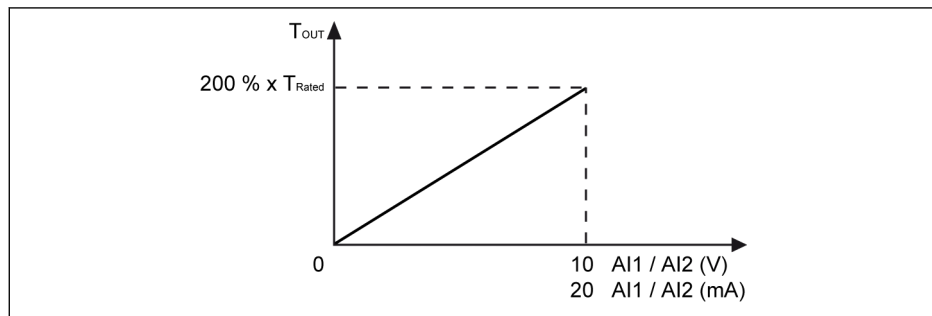

Fig. 12-62: Torque reference characteristic curve

Step 3: Set the direction of torque reference

Code	Name	Setting range	Default	Min.	Attri.
E0.01	First run command source	0: Operating panel 1: Multi-function digital input 2: Communication	0	1	Stop

Example 1:

[E0.01] = '0: Operating panel'

[C3.41] = '0: AI1'

[C3.42] = 0.0 %

[C3.43] = 100.0 %

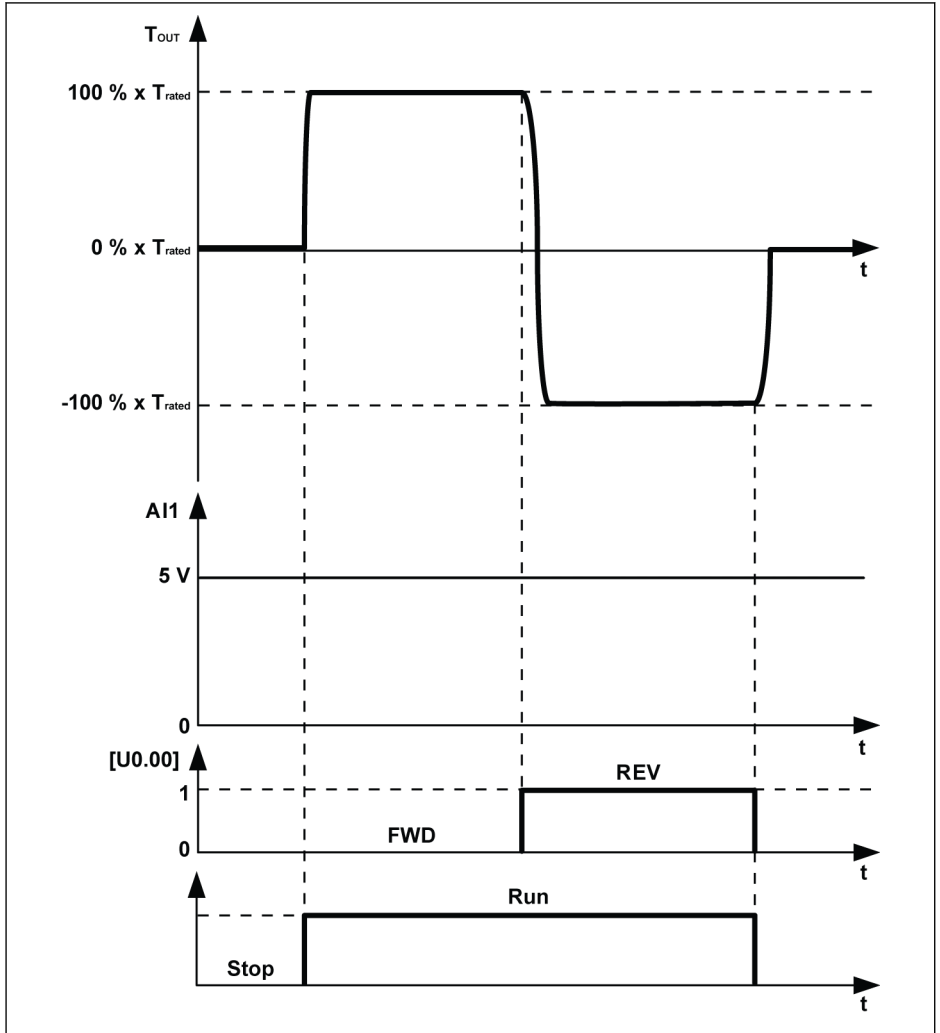
 T_{OUT} Output torque T_{rated} Rated torque

t Time

FWD Forward

REV Reverse

Run Run command

Stop Stop command

Fig. 12-63: Set the direction of torque reference by operating panel**Example 2:**

[E0.01] = '1: Multi-function digital input'

[E1.15] = '0: 2-wire forward / stop, reverse / stop'

[E1.00] = '35: Forward running (FWD)', [E1.01] = '36: Reverse running (REV)'

[C3.41] = '0: AI1', [C3.42] = 0.0 %, [C3.43] = 150.0 %

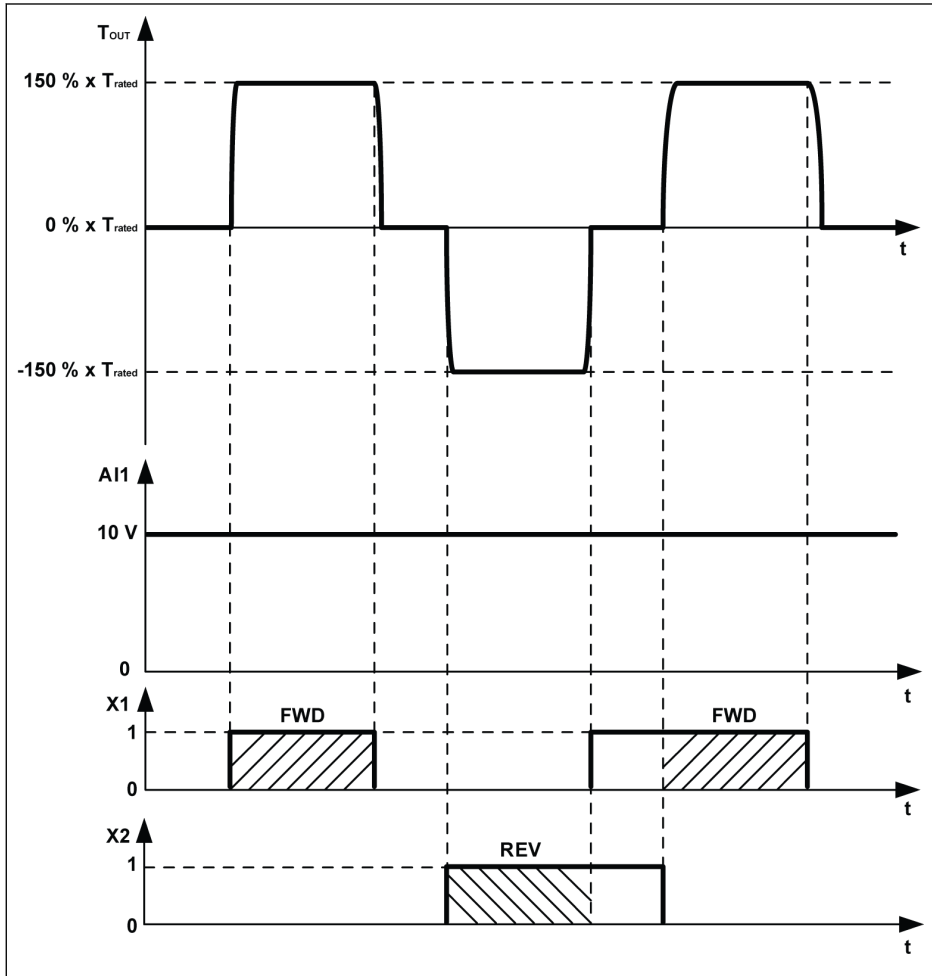

T_{OUT} Output torque
 T_{rated} Rated torque
 t Time
 FWD Forward

REV Reverse
 X1 X1 input
 X2 X2 input

Fig. 12-64: Set the direction of torque reference by digital input

For run command setting source information, see [chapter 12.5 "Run- / Stop- / Direction Command Source"](#) on page 116.

13 Diagnosis

13.1 Display of LED Characters

Character	A	b	C	d	E	F	H	I	L
Display									
Character	n	O	o	P	r	S	t	U	-
Display									

Tab. 13-1: Display of LED characters

13.2 Status Code

Code	Description
8.8.8.8.8.	Displayed at power on, detecting the operating panel
'''''''''''''''''''''	During parameter backup...
tUnE	Motor parameter tuning
PSLP	PID sleeping
-PF-	Modified parameters which are different from default value

13.3 Warning Code

Code	Description
P.oFF	Displayed only at power down / drop in stop state
S.Err	Parameter change blocked
C-dr	Displayed if 'Communication error detection time' exceeds the defined value when 'Communication error protection mode' is set to '1: Keep running'
PrSE	Parameter setting contradiction
FLE	Fan maintenance period expired
noCP	No modified parameter
PLE	Pump leakage
Aib-	Analog input broken wire detection

13.4 Error Code

13.4.1 Error 1 (OC-1): Overcurrent at Constant Speed

Possible reason	Solution
Sudden load change in run mode	Reduce occurrence and scale of sudden change
Low mains voltage	Check input power supply
Motor power and frequency converter power do not match	Motor power has to match with frequency converter power
Excessive inertia or load	Check power of motor and frequency converter, check load
The motor cable is too long	<ul style="list-style-type: none"> ● Decrease the carrier frequency (C0.05) ● Use a frequency converter with larger power
Excessive torque compensation	Reduce torque compensation setting (C2.22) till the current decreases

13.4.2 Error 2 (OC-2): Overcurrent during Acceleration

Possible reason	Solution
Excessively short acceleration time	Increase acceleration time (E0.26)
Excessive start-up frequency	Reduce start frequency (E0.36)
Excessive load rotation inertia or impact	Increase acceleration time (E0.26), reduce sudden load change
Running command active while motor is coasting	Restart after motor stop or start with speed capture (E0.35)
Wrong setting of V/f curve related parameters	Adjust setting of V/f curve related parameters
Motor power and frequency converter power do not match	Motor power has to match with frequency converter power
Excessive torque compensation	Reduce torque compensation setting (C2.22) till the current decreases
Wrong motor parameters setting	Correct motor parameters setting

13.4.3 Error 3 (OC-3): Overcurrent during Deceleration

Possible reason	Solution
Excessively short deceleration time	Increase deceleration time (E0.27)
Excessive load rotation inertia	Use suitable brake components
Motor power and frequency converter power do not match	Motor power has to match with frequency converter power
Excessive overexcitation braking factor	Reduce [E0.55]
Wrong motor parameter setting	Correct motor parameters setting

13.4.4 Error 4 (OE-1): Overvoltage at Constant Speed

Possible reason	Solution
Surge voltage from power supply	Check input power supply
Motor to earth short circuit causes DC-bus capacitors overcharged	Check motor connection
Excessive load rotation inertia	Use suitable brake components
Noise interference	Check wiring of control circuit, main circuit and grounding

13.4.5 Error 5 (OE-2): Overvoltage during Acceleration

Possible reason	Solution
Surge voltage from power supply	Check input power supply
Motor to earth short circuit causes DC-bus capacitors overcharged	Check motor connection
Direct start during motor running	Restart after motor stop or start with speed capture (E0.35)
Excessively short acceleration time	Increase acceleration time (E0.26) or use S-curve (E0.25, E0.28, E0.29)

13.4.6 Error 6 (OE-3): Overvoltage during Deceleration

Possible reason	Solution
Surge voltage from power supply	Check input power supply
Motor to earth short circuit causes DC-bus capacitors overcharged	Check motor connection
Excessive load rotation inertia	Use suitable brake components
Excessively short deceleration time	<ul style="list-style-type: none"> ● Increase deceleration time (E0.27) ● Use a brake resistor or a brake resistor unit ● Enable stall overvoltage prevention during deceleration (C0.25)
Wrong wiring of brake resistor	Check the wiring of brake resistor
The brake chopper is damaged	Contact with service

13.4.7 Error 7 (OE-4): Overvoltage during Stop

Possible reason	Solution
Excessive inertia on the load	<ul style="list-style-type: none"> ● Increase deceleration time (E0.27) ● Use suitable brake components
Surge voltage from the power supply	Check input power supply

13.4.8 Error 8 (UE-1): Undervoltage during Run

Possible reason	Solution
Power failure during running	Check input power supply
Main circuit capacitor deterioration	Contact with service

13.4.9 Error 9 (SC): Current Surge or Short Circuit

Possible reason	Solution
External phase-phase short circuit of motor	Check motor wiring
Earth surge	Remove the short circuit and check motor
Internal error of power module	Contact with service
Current surge	Increase the acceleration time (E0.26), reduce the overexcitation braking factor (E0.55)

13.4.10 Error 10 (IPH.L): Input Phase Loss

Possible reason	Solution
Abnormal, omitted or broken connections of frequency converter power supply	Check power supply connections, remove omitted or broken connections
Broken fuse	Check fuse
Imbalance in the three phases of input power supply	Check if the imbalance situation exceeds converter withstand capability
Main circuit capacitor deterioration	Contact with service

13.4.11 Error 11 (OPH.L): Output Phase Loss

Possible reason	Solution
Abnormal, omitted or broken connections of frequency converter outputs	Check the connections of frequency converter outputs, remove omitted or broken connections
Imbalance in the three phases of outputs	Check motor

13.4.12 Error 12 (ESS-): Soft Start Error

Possible reason	Solution
Soft start resistor value has been changed due to over temperature	Contact with service
Power failure	Check the input power supply
Input phase loss occurs during start-up (3 phase)	Remove the input phase loss
Main circuit capacitor deterioration	Contact with service

13.4.13 Error 20 (OL-1): Converter Overload

Possible reason	Solution
Long time overload	Reduce overload time, reduce load
Wrong settings of V/f curve related parameters	Adjust settings of V/f curve related parameters
Motor power and frequency converter power do not match	Motor power has to match with frequency converter power
Overload happens at lower speed	<ul style="list-style-type: none"> ● Reduce load at lower speed ● Reduce the carrier frequency (C0.05) ● Use a frequency converter with larger power
Excessive load, excessive short Acc. / Dec. time or cycle	<ul style="list-style-type: none"> ● Adjust load, acceleration/deceleration time or cycle ● Use a frequency converter with larger power
Low mains voltage	Check input power supply
Excessive torque compensation	Reduce torque compensation setting (C2.22) till the current decreases

13.4.14 Error 21 (OH): Converter over Temperature

Possible reason	Solution
Frequency converter (heat sink) temperature is higher than max. allowable temperature 85 °C	<ul style="list-style-type: none"> ● Reduce ambient temperature, improve ventilation and heat dissipation; clear dust, cotton wadding in air ducts; check fan and its power supply connection (if available) ● Reduce load if necessary ● Reduce carrier frequency (C0.05)
Temperature detection circuit error	Contact with service

13.4.15 Error 22 (UH): Converter under Temperature

Possible reason	Solution
Ambient temperature is lower than -10 °C	Provide a reasonable ambient temperature that frequency converter requires
Temperature sensor defect	Contact with service

13.4.16 Error 23 (FF): Fan Failure

Possible reason	Solution
Fan defect	Contact with service

13.4.17 Error 24 (Pdr): Pump Dry

Possible reason	Solution
PID feedback is excessively low while converter is running at output frequency high limit	<ul style="list-style-type: none"> ● Check if the feedback signal is valid ● If the PID control is used for controlling a water pump, check if the pump is running without water

13.4.18 Error 30 (OL-2): Motor Overload

Possible reason	Solution
Motor locked	Prevent motor lock
Normal motor runs long time with large load at low speed	<ul style="list-style-type: none"> ● Increase frequency converter output frequency ● Reduce load ● Use variable frequency motor or set zero speed load (C1.76) to a higher value ● Set correct motor thermal protection time constant (C1.74)
Low mains voltage	Check input power supply
Wrong settings of V/f curve related parameters	Adjust settings of V/f curve related parameters
Excessive sudden load change	Check load
Wrong input of rated motor current	Correct rated motor current in (C1.07)
Multiple motors are driven by one frequency converter	Connect only one motor to the frequency converter
Excessive overexcitation braking factor	Reduce [E0.55]
Wrong motor protection parameter settings	Adjust settings of C1.74, C1.75 and C1.76 according to actual motor situations

13.4.19 Error 31 (Ot): Motor over Temperature

Possible reason	Solution
Excessive load or bad cooling	<ul style="list-style-type: none"> ● Check load ● Provide a better cooling condition
Temperature sensor defect	Check the motor temperature sensor feedback signal
Wrong motor protection parameter settings	Different motor with different maximum temperature, set motor protection parameters according to actual protection circuits (C1.72, C1.73, C1.74)

13.4.20 Error 32 (t-Er): Motor Parameter Tuning Error

Possible reason	Solution
Motor power and frequency converter power do not match	Motor power has to match with frequency converter power
Wrong setting of motor parameters	Correct motor parameters setting according to motor name-plate
No connection of converter and motor	Check motor cable connections

13.4.21 Error 38 (AibE): Analog Input Broken Wire Detection

Possible reason	Solution
Analog input wire is disconnected	Check wiring of AI1 and AI2

13.4.22 Error 40 (dir1): Forward Running Lock Error

Possible reason	Solution
Direction control [E0.17] = '1: Forward only' Direction command is reverse	Correct the parameter setting

13.4.23 Error 41 (dir2): Reverse Running Lock Error

Possible reason	Solution
Direction control [E0.17] = '2: Reverse only' Direction command is forward	Correct the parameter setting

13.4.24 Error 42 (E-St): Terminal Error Signal

Possible reason	Solution
External error caused by input signals via external terminals	Check external terminals status
Wrong wiring / setting of multi-function external terminals	Ensure the right external signals have been connected correctly to the right multi-function external terminals which are assigned for external error input ([E1.00]...[E1.04] = 32, 33)
Converter stop caused by E-Stop active command via Modbus communication	Check the stop command via Modbus communication (0X0088: stop according to parameter setting; 0X0090: E-stop active). If converter receives 0X0090, E-St will be displayed

13.4.25 Error 43 (FFE-): Firmware Version Mismatch

Possible reason	Solution
Operating panel may be placed to the frequency converter with older/newer firmware	Contact with service
Control board may be removed to another device	Contact with service

13.4.26 Error 44 (rS-): Modbus Communication Error

Possible reason	Solution
Device connection problem	Check device communication connection
Communication target error	Check status of communication target

13.4.27 Error 50 (idE-): Converter Internal Error

Possible reason	Solution
Internal error occurs	Contact with service

13.4.28 Error 55 (PbrE): Parameter Backup / Restore Error

Possible reason	Solution
Error occurs during parameter backup/restore process	Contact with service

13.5 Error Handling

13.5.1 Restarting after Power Loss

Code	Name	Setting range	Default	Min.	Attri.
E0.45	Power loss restart	0: Inactive 1: Active	0	-	Stop
E0.46	Power loss restart delay	0.0...10.0	1.0	0.1	Stop

[E0.45] decides the restart behavior after power loss:

- Run command source is from panel
 - [E0.45] = 0
The frequency converter only starts after pressing **<Run>** button.
 - [E0.45] = 1
The frequency converter will automatically start after [E0.46] 'Power loss restart delay' without pressing the **<Run>** button after power on.
- Run command source is not from panel
 - [E0.45] = 0
The frequency converter remains static even if a running command exists after power on. To start the frequency converter, deactivate and then reactivate the running command.
 - [E0.45] = 1
The frequency converter will automatically start after [E0.46] 'Power loss restart delay' only if a running command is active after power on.



- If the frequency converter was running in 3-wire mode before power loss, the restart of the frequency converter is decided by the status of this 3-wire terminal after power on.
- If the power loss was caused by power supply interference, an error code 'UE-1' will be displayed on the operating panel in undervoltage situation, and the frequency converter will not restart automatically after power on even setting [E0.45] = 1.
- If the run command is from communication, the frequency converter **ONLY** restarts after sending a stop command first and then sending a run command by communication.

13.5.2 Automatic Error Reset

Automatic error reset function is used to ensure continuous running without human intervention in the case of occasional errors, such as overcurrent or overvoltage at start or in the run mode. This function can be activated by setting [E9.00] ≠ 0.

When an error occurs, the frequency converter stops the output and the related error code is displayed at the same time. The system remains in idle mode for delay time [E9.01]. Then the error will automatically be reset and a run command will be generated to restart the frequency converter. This sequence will be performed [E9.00] times. If the error still exists, the frequency converter remains in idle mode and no longer performs automatic restart attempts. In this case, a manual error reset is required to resume the operation.

Automatic error reset is valid for the following errors: OC-1, OC-2, OC-3, OE-1, OE-2, OE-3, OE-4, OL-1, OL-2, UE-1, E-St, OH and UH.

Code	Name	Setting range	Default	Min.	Attri.
E9.00	Automatic error reset attempts	0...3 (0: Inactive)	0	–	Stop
E9.01	Automatic error reset interval	2...60 s	10	1	Stop

13.5.3 Error Reset by X1...X5 Digital Input

The error reset input can be defined with one X1...X5 digital input. This function works in the same manner as the panel error reset function does, which allows remote error reset. 'Error reset signal' is edge sensitive.

Code	Name	Setting range	Default	Min.	Attri.
E1.00	X1 input	34: Error reset signal	0	1	Stop
E1.01	X2 input		0	1	Stop
E1.02	X3 input		0	1	Stop
E1.03	X4 input		0	1	Stop
E1.04	X5 input		0	1	Stop

Set the respective parameter of any X1...X5 input as '34: Error reset signal':

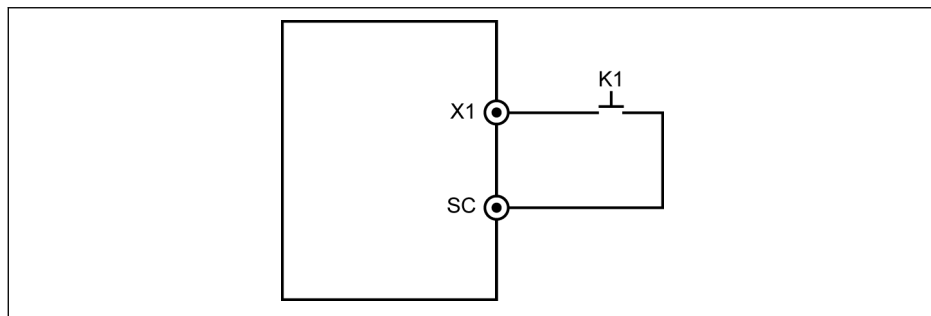

Fig. 13-1: Error reset via digital input

14 Communication

14.1 Brief Introduction

EFC x610 frequency converters provide standard RS485 communication interface to realize the communication between the master and slaves via Modbus protocol. With the help of a PC, a PLC or an external computer a 'single master / multiple slaves' network control can be realized (setting of frequency control command and running frequency, modification of parameters, monitoring of frequency converter running status and error messages) to address the specific requirements of applications.

14.2 Basic Communication Settings

14.2.1 Selection of the Communication Protocol

The standard product only supports Modbus communication protocol. To use other communication protocols, optional communication cards need to be ordered additionally and parameter E8.00 and other related parameters need to be set accordingly.

Code	Name	Setting range	Default	Min.	Attri.
E8.00	Communication protocol	0: Modbus	0	-	Stop

14.2.2 Setting the Data Transmission Rate

Data transmission rate refers to the transmission rate of data between the external computer and the frequency converter.

Code	Name	Setting range	Default	Min.	Attri.
E8.10	Modbus baud rate	0: 1,200 bps 1: 2,400 bps 2: 4,800 bps 3: 9,600 bps 4: 19,200 bps 5: 38,400 bps	3	-	Stop

14.2.3 Setting the Data Format

Code	Name	Setting range	Default	Min.	Attri.
E8.11	Modbus data format	0...3	0	-	Stop

- 0: 1 start bit, 8 data bits, 1 stop bit, no parity
- 1: 1 start bit, 8 data bits, 1 stop bit, even parity
- 2: 1 start bit, 8 data bits, 1 stop bit, odd parity
- 3: 1 start bit, 8 data bits, 2 stop bits, no parity



The data format of the converter must be the same as that of the master station. Otherwise, normal communication is impossible.

14.2.4 Setting the Local Address

In Modbus communication, the maximum number of frequency converters in the network is 247. Each frequency converter must have a unique local address.

Code	Name	Setting range	Default	Min.	Attri.
E8.12	Modbus local address	1...247	1	1	Stop

14.2.5 Setting Command Signal Type

Code	Name	Setting range	Default	Min.	Attri.
E8.13	Modbus level / edge sensitivity selection	0: Level sensitive 1: Edge sensitive	1	-	Stop

Level sensitive (default situation): The control word is not a real edge sensitive, master should manually reset the command.

For example:

1. Simulate an error
2. Set bit5 = 1, the error is reset
3. Simulate an error again
4. Set bit5 = 1, the error is not reset
5. Master should set bit5 = 0 firstly, then set bit5 = 1, the error is reset

Edge sensitive (selectable): The control command is reset automatically after the activation.

For example:

1. Simulate an error
2. Set bit 5 = 1, the error is reset
3. Simulate an error again
4. Set bit 5 = 1, the error is reset

14.2.6 Communication Disruption and Response

Code	Name	Setting range	Default	Min.	Attri.
E8.01	Communication error detection time	0.0...60.0 s (0.0: Inactive)	0.0	0.1	Stop
E8.02	Communication error protection mode	0, 1	1	-	Stop

- When [E8.01] = 0.0 s, the disruption detection function is inactive.
- If the interval between the current and next communication commands exceeds the time defined in [E8.01] 'Communication error detection time', the frequency converter will reports a communication error code and act as defined in [E8.02] 'Communication error protection mode':
 - [E8.02] = 0: Freewheeling to stop
The motor freewheels to stop after the communication timeout no matter the settings of parameter E0.50 'Stop mode'.
 - [E8.02] = 1: Keep running
The motor continues running at the setting frequency, and warning code 'C-dr' will be displayed on the operating panel.

14.3 Modbus Protocol

14.3.1 Protocol Description

Brief introduction

- Modbus is a master / slave protocol. Only one device may send commands in the network at a particular time.
- The master station manages message exchange by polling the slave stations. Unless being approved by the master station, no slave station may send message. In case of an error during data exchange, if no response is received, the master station will query the slave stations absent from the polling.
- If a slave station is unable to recognize a message from the master station, an exception response will be sent to the master station.
- Slave stations cannot communicate with each other but through the master's software which reads data from one slave station and sends them to another. There are two types of dialogs between the master station and the slave stations:
 - The master station sends a request to a slave station and waits for its response.
 - The master station sends a request to all slave stations and does not wait for their response (broadcasting).

Transmission

The transmission is of RTU (Remote Terminal Unit) mode with frames containing no message header or end mark. A typical RTU frame format is shown below:

Slave address	Function code	Data	CRC
1 byte	1 byte	0...252 byte(s)	CRC low CRC high

Tab. 14-1: Typical RTU frame format



- Data are transmitted in binary codes.
- CRC: Cyclic redundancy code.

- The address 0 is reserved as broadcast address.
- All slave nodes must recognize the broadcast address for writing function (no need of reply).
- The master node has no specific address, only the slave nodes must have addresses (1...247).

For RTU transmission mode, four types of character format are shown below:

- 1 start bit, 8 data bits, 1 stop bit, no parity
- 1 start bit, 8 data bits, 1 stop bit, even parity
- 1 start bit, 8 data bits, 1 stop bit, odd parity
- 1 start bit, 8 data bits, 2 stop bits, no parity

The character or byte is sent in the following sequence (from left to right):

<-Least significant bit (LSB)					Most significant bit (MSB)->					
Start	1	2	3	4	5	6	7	8	Stop	-
Start	1	2	3	4	5	6	7	8	Even	Stop
Start	1	2	3	4	5	6	7	8	Odd	Stop
Start	1	2	3	4	5	6	7	8	Stop	Stop

Tab. 14-2: RTU transmission mode

Message frames are separated by a silent interval of at least 3.5 characters' time. The entire frame must be transmitted as a continuous stream of bytes. If the interval of two separated frames is less than 3.5 characters' time, then the slave address of second frame will be treated as the part of first frame by mistake, due to the confusion of the frames, the CRC check will fail and lead to communication fault. If a silent interval of more than 1.5 characters' time occurs between two bytes, the message frame is regarded incomplete and discarded by the receiver.

14.3.2 Modbus Interface

The Modbus communication is via RS485 interface, see descriptions on RS485+ and RS485- in [chapter 8.1 "Wiring Diagram" on page 31](#) and [chapter 8.3.2 "Control Terminals" on page 40](#).

14.3.3 Modbus Function and Message Format

Supported functions

The main function of Modbus is to read and to write parameters. Different function codes decide different operation requests. Modbus functions managed by EFC x610 and their limits are shown in the table below:

Code	Function name	Broadcast	Max. value of N
3 = 0x03	Read N register words	NO	16
6 = 0x06	Write one register word	YES	-
8 = 0x08	Diagnosis	NO	-
16 = 0x10	Write N register words	YES	16
23 = 0x17	Read/write N register words	NO	16

Tab. 14-3: EFC x610 Modbus functions and limits



'Read' and 'Write' are considered from the prospect of the master station.

Modbus message formats are different according to the function codes shown below.

Slave No.	0x03	Address of 1 st word	Number of words	CRC16
		Hi Lo	Hi Lo	Lo Hi

Tab. 14-4: Function 3_Request from the master

Slave No.	0x03	Number of bytes	1 st word value	-	Last word value	CRC16
		Depends on master request	Hi Lo	-	Hi Lo	Lo Hi

Tab. 14-5: Function 3_Response from the slave

Slave No.	0x06	Address of word	Value of word	CRC16
		Hi Lo	Hi Lo	Lo Hi

Tab. 14-6: Function 6_Master request and slave response (in same format)

Slave No.	0x08	Test word 1	Test word 2	CRC16
		Hi Lo	Hi Lo	Lo Hi

Tab. 14-7: Function 8_Master request and slave response (in same format)

Slave No.	0x10	Address of 1 st word	Number of words	Number of bytes	1 st word value	–	Last word value	CRC16
		Hi Lo	Hi Lo		Hi Lo	–	Hi Lo	Lo Hi

Tab. 14-8: Function 16_Request from the master

Slave No.	0x10	Address of 1 st word	Number of words	CRC16
		Hi Lo	Hi Lo	Lo Hi

Tab. 14-9: Function 16_Response from the slave

Slave No.	0x17	Address of 1 st word to be read	Number of words to be read	Address of 1 st word to be written
		Hi Lo	Hi Lo	Hi Lo

Number of words to be written	Number of bytes to be written	Value of 1 st word to be written	–	Value of last word to be written	CRC16
Hi Lo		Hi Lo	–	Hi Lo	Lo Hi

Tab. 14-10: Function 23_Request from the master

Slave No.	0x17	Number of bytes	1 st word value read	–	Last word value read	CRC16
			Hi Lo	–	Hi Lo	Lo Hi

Tab. 14-11: Function 23_Response from the slave

Function example

Function 0x03: Read N register words, range: 1...16

Example: It is necessary to read 2 continuous words starting from communication register 3000H of the slave frequency converter addressed at 01H. The frame structure is described in the tables below.

Message start	Transmission time for 3.5 bytes
Slave address	01H
Modbus function code	03H
Higher byte of start address	30H
Lower byte of start address	00H
Higher byte of data	00H
Lower byte of data	02H
CRC lower byte	CBH
CRC higher byte	0BH
Message end	Transmission time for 3.5 bytes

Tab. 14-12: Function 0x03_Request from RTU master

Message start	Transmission time for 3.5 bytes
Slave address	01H
Modbus function code	03H
Bytes of data	04H
Higher byte of data in register 0100H	00H
Lower byte of data in register 0100H	14H
Higher byte of data in register 0101H	00H
Lower byte of data in register 0101H	02H
CRC lower byte	3BH
CRC higher byte	F6H
Message end	Transmission time for 3.5 bytes

Tab. 14-13: Function 0x03_Response from RTU slave

Function 0x06: Write one register word**⚠ CAUTION****Frequent writing may damage the internal registers!**

- When data is written into the internal registers, there is a limit on the writing times. The register address may be damaged once the writing times is beyond the writing limit. So please avoid frequent writing!
- For details of user writing permission, please see [chapter 19.3.1 "Terminology and Abbreviation in Parameter List" on page 253](#).

Example: Write 0000H to communication register address 3002H of the slave frequency converter with address 01H. The frame structure is described in the tables below:

Message start	Transmission time for 3.5 bytes
Slave address	01H
Modbus function code	06H
Higher byte of write register address	30H
Lower byte of write register address	02H
Higher byte of write data	00H
Lower byte of write data	00H
CRC lower byte	27H
CRC higher byte	0AH
Message end	Transmission time for 3.5 bytes

Tab. 14-14: Function 0x06_Request from RTU master

Message start	Transmission time for 3.5 bytes
Slave address	01H
Modbus function code	06H
Higher byte of write register address	30H
Lower byte of write register address	02H
Higher byte of write data	00H
Lower byte of write data	00H
CRC lower byte	27H
CRC higher byte	0AH
Message end	Transmission time for 3.5 bytes

Tab. 14-15: Function 0x06_Response from RTU slave

Function 0x08: Diagnostics

Example: To test the communication loop of 2 continuous words 1234H and 5678H with frequency converter slave address 01H, the frame structure is described in the tables below:

Message start	Transmission time for 3.5 bytes
Slave address	01H
Modbus function code	08H
Higher byte of sub-function	00H
Lower byte of sub-function	00H
Higher byte of test word 1	12H
Lower byte of test word 1	34H
Higher byte of test word 2	56H
Lower byte of test word 2	78H
CRC lower byte	73H
CRC higher byte	33H
Message end	Transmission time for 3.5 bytes

Tab. 14-16: Function 0x08_Request from RTU master

Message start	Transmission time for 3.5 bytes
Slave address	01H
Modbus function code	08H
Higher byte of sub-function	00H
Lower byte of sub-function	00H
Higher byte of test word 1	12H
Lower byte of test word 1	34H
Higher byte of test word 2	56H
Lower byte of test word 2	78H
CRC lower byte	73H
CRC higher byte	33H
Message end	Transmission time for 3.5 bytes

Tab. 14-17: Function 0x08_Response from RTU slave

Function 0x10: Write N register words, range: 1...16

Example: To modify 2 continuous registers start from 4000H with words 0001H and 0000H with slave frequency converter address 01H. The frame structure is described in the tables below:

Message start	Transmission time for 3.5 bytes
Slave address	01H
Modbus function code	10H
Higher byte of write register start address	40H
Lower byte of write register start address	00H
Higher byte of register number	00H
Lower byte of register number	02H
Bytes of data	04H
Higher byte of data in register 0109H	00H
Lower byte of data in register 0109H	01H
Higher byte of data in register 010AH	00H
Lower byte of data in register 010AH	00H
CRC lower byte	93H
CRC higher byte	ACH
Message end	Transmission time for 3.5 bytes

Tab. 14-18: Function 0x10_Request from RTU master

Message start	Transmission time for 3.5 bytes
Slave address	01H
Modbus function code	10H
Higher byte of write register start address	40H
Lower byte of write register start address	00H
Higher byte of register number	00H
Lower byte of register number	02H
CRC lower byte	54H
CRC higher byte	08H
Message end	Transmission time for 3.5 bytes

Tab. 14-19: Function 0x10_Response from RTU slave

Function 0x17: Read/Write N register words, range: 1...16

Example: To read data in 2 continuous registers starting from address 3000H, write 0001H and 0000H to 2 continuous registers starting from address 4000H. The frame structure is described in the tables below:

Message start	Transmission time for 3.5 bytes
Slave address	01H
Modbus function code	17H
Higher byte of read register start address	30H
Lower byte of read register start address	00H
Higher byte of read register number	00H
Lower byte of read register number	02H
Higher byte of write register start address	40H
Lower byte of write register start address	00H
Higher byte of write register number	00H
Lower byte of write register number	02H
Bytes of data for writing	04H
Higher byte of data in register 0109H	00H
Lower byte of data in register 0109H	01H
Higher byte of data in register 010AH	00H
Lower byte of data in register 010AH	00H
CRC lower byte	E6H
CRC higher byte	B3H
Message end	Transmission time for 3.5 bytes

Tab. 14-20: Function 0x17_Request from RTU master

Message start	Transmission time for 3.5 bytes
Slave address	01H
Modbus function code	17H
Bytes of read register	04H
Higher byte of read register 0100H	00H
Lower byte of read register 0100H	14H
Higher byte of read register 0101H	00H
Lower byte of read register 0101H	02H
CRC lower byte	38H
CRC higher byte	E2H
Message end	Transmission time for 3.5 bytes

Tab. 14-21: Function 0x17_Response from RTU slave

Error code and exception code

If a slave receives the request without a communication error, but cannot handle it, the slave will return an exception response which includes error code and exception code informing the master of the nature of the error. The error code is formed by setting the MSB of the function code to 1 (i.e. function code plus with 0x80, like 0x83, 0x86, 0x90, 0x97), then the exception response has a format shown below.

Slave No.	Error code	Exception code	CRC16
			Lo Hi

Exception codes for EFC x610 frequency converters:

- 1 = Parameter cannot be modify owing to user password locked
- 2 = The function requested is not recognized by the slave, i.e. not equal to 3, 6, 8, 16 or 23
- 3 = The word address indicated in the request do not exist in the slave
- 4 = The word values indicated in the request are not permissible in the slave
- 5 = Parameters cannot be modify in run mode
- 6 = Parameters are read-only that cannot be modified
- 7 = Invalid operation which is decided by the function of frequency converter^(*)
- 9 = EEPROM read/write error
- B = Function code 3, read range exceeds 16



^(*) includes situations listed below:

- Write operations on b0.11 'Parameter replication', U1.00 'Running monitoring display', U1.10 'Stop monitoring display' and C1.01 'Motor parameter tuning', are prohibited.
- Write operations on b0.20 'User password', b0.21 'Manufacture password' and b0.10 'Parameter initialization' only support function 6.
- Multi-function digital input terminals (E1.00...E1.04) writing operation do not permit repeated non-zero value.

14.3.4 Communication Mapping Register Address Distribution

Frequency converter parameter registers

Frequency converter parameter registers correspond to the function codes one-to-one. Reading and writing of related function codes can be achieved through reading and writing of the contents in frequency converter parameter registers via Modbus communication. The characteristics and scope of reading and writing function codes are in compliance with the frequency converter function code description. The address of a frequency converter parameter register is composed of a higher byte representing the function code group and a lower byte representing the index in the group. The groups are mapped as follows:

Address high byte	0x00	0x20	0x21	0x22	0x30	0x31	0x32	0x33	0x34	0x35	0x38	0x39	0x40	0x41	0x10
Group	b0	C0	C1	C2	E0	E1	E2	E3	E4	E5	E8	E9	U0	U1	d0

Tab. 14-22: Frequency converter parameter registers



Parameters of the monitoring group (Group d0) are always write-protected.

Examples:

To read out the module temperature (d0.20) of EFC x610 frequency converter, use register address 0x1014 (0x10 = Group d0, index 0x14 = 20).

To set V/f curve mode (C2.00) of EFC x610 frequency converter, use register address 0x2200 (0x22 = Group C2, index 0).

Access to a non-existing function code will be acknowledged with exception code 3 (see [chapter 14.3.3 "Modbus Function and Message Format" on page 208](#)).

Communication control registers

The address of command word register for communication control is 0x7F00. This register is write-only. The frequency converter is controlled through writing data into the address. The definition of each bit is shown in table below:

bit	Value	Description
15...8	–	Reserved
7	1	Control word active
	0	Inactive
6	1	Stop Acc. / Dec. active (stop the internal Acc. / Dec. ramp generator)
	0	Inactive
5	1	Fault reset active
	0	Inactive
4	1	E-stop active
	0	Inactive
3	1	Stop according to parameter setting
	0	Inactive
2	1	Reverse
	0	Forward
1	1	Jog active (jogging direction determined by bit 2)
	0	Inactive
0	1	Run command active
	0	Inactive

Tab. 14-23: Communication control registers

The address of frequency setting register for communication control is 0x7F01. This register is for read and write. When 'First frequency setting source' [E0.00] = '20: Communication', the frequency converter can be set with writing data to this address.

If the communication frame check is successful (CRC valid), the frequency converter always accepts the content of the control word. All conflicts (e.g. run command and stop command active at the same time) are resolved by the application functionality (Run / Stop generator, jog control...). This assures that the frequency converter will always react in the same manner, independent of the run command source.

Communication state feedback registers (0x7FA0)

The frequency converter state can be monitored by reading the register. This register is read-only. The definition of each bit is shown in the table below:

bit	Value	Description
15 ... 8	-	Error code (equals to [E9.05])
7	1	Error
	0	No error
6	1	Stall over current
	0	Normal
5	1	Stall over voltage
	0	Normal
4	1	Decelerating
	0	Not in deceleration
3	1	Accelerating
	0	Not in acceleration
2	1	Jogging
	0	Not in jog
1	1	Running
	0	Stop
0	1	Reverse
	0	Forward

Tab. 14-24: Communication state feedback registers (0x7FA0)

14.3.5 Modbus Communication Example

One slave address is 01H. The frequency setting of the frequency converter has been set to 'Given by communication' and the RUN command source is set to 'Inputting commands by communication'. It is required for the motor connected to the frequency converter to run with 50 Hz (forward rotation). The operation can be achieved with function 0x10 (function 16) of the Modbus protocol. The messages of the requests from the master and responses from the slave are shown in table below:

- Example 1: Start 01# frequency converter for forward rotation at frequency of 50.00 Hz (represented by 5000 internally)

	Slave address	Function code	Start address	Number of address	Bytes of data	Data content	CRC code
Request	0x01	0x10	0x7F00	0x0002	0x04	0x0081 0x1388	0x8AE3
Response	0x01	0x10	0x7F00	0x0002	N/A	N/A	0x581C

- Example 2: Read the output frequency of 01# frequency converter and output velocity

	Slave address	Function code	Start address	Number of address	Bytes of data	Data content	CRC code
Request	0x01	0x03	0x1000	0x0002	N/A	N/A	C0CB
Response	0x01	0x03	N/A	N/A	0x04	0x1388 0x05DC	0x7C54

- Example 3: Stop 01# frequency converter according to the stopping mode with the function code

	Slave address	Function code	Start address	Number of address	Bytes of data	Data content	CRC code
Request	0x01	0x06	0x7F00	N/A	N/A	0x0088	0x9078
Response	0x01	0x06	0x7F00	N/A	N/A	0x0088	0x9078

14.3.6 Special Notes

1. The external computer can not write to function codes b0.11 'Parameter replication', U1.00 'running monitoring display' and U1.10 'Stop monitoring display'.
2. b0.20 'User password' and b0.10 'Parameter initialization' do not support multiple write including single write in multiple write; Motor nameplate parameters and motor physical data should not be modified simultaneously; Multi-function digital input terminals (E1.00...E0.04) writing operation do not permit repeated non-zero value.
3. If the communication protocol is changed, baud rate, data frame and local address will be restored to factory default.
4. The read response of user password and manufacture password is '0000' in case of external computer reading.
5. The external computer can set, modify or cancel user password, the specific operation is same to the situation when 'Running command source' is from the operating panel.
6. The access to control registers and state registers is not limited by user password.

14.3.7 Communication Networking

Networking

The communication network is shown in figure below, with a PC, a PLC or an external computer as the master and all frequency converters as slaves, which are connected by shielded twisted pair cables. The slave at the end of the network needs a termination resistor with recommended value of $120\ \Omega$, $0.25\ \text{W}$.

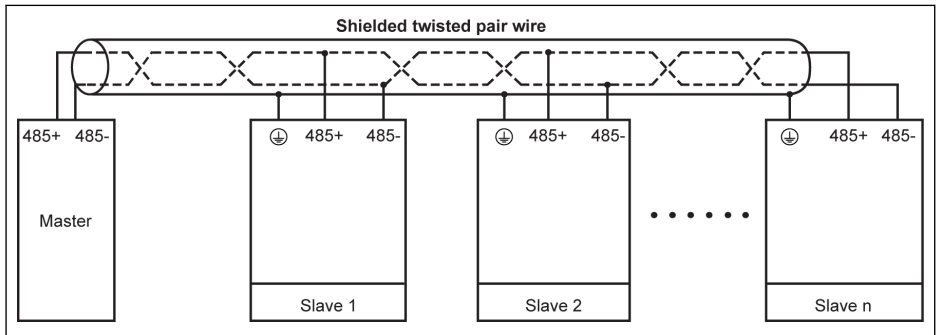

Fig. 14-1: Communication networking



- The maximum length of the communication cable is 300 m.
- The maximum length of the communication cable is 80 m if the number of slaves is less than 5.
- If the Modbus network cannot work successfully, check if a bias resistor has been installed for the master device and make sure that its resistance is not more than $1.5\ \text{k}\Omega$.

⚠ WARNING

Cables may only be connected when the frequency converters are switched off!

Recommendations on networking

- Use shielded twisted pair cable to connect RS485 links.
- Modbus cable should be adequately away from power cables (minimum 30 cm).
- Avoid crossing of Modbus cables and power cables and use orthogonal crossing if crossing must be used.
- The shielding layer of cables should be connected to protected ground or to equipment ground if the equipment ground has already been connected to protected ground. Do not directly ground any point of the RS485 network.
- In no circumstance should ground cables constitute a loop.

15 Accessories

15.1 Optional Accessories

Optional accessories	EFC 3610	EFC 5610
LED panel	√	√
Dust cover	√	√
External EMC filter	√	√
Panel mounting plate	√	√
Communication cable for cabinet control	√	√

Tab. 15-1: Optional accessories

15.2 External EMC Filter

15.2.1 External EMC Filter Type

EFC x610 model	External EMC filter type
0K40-1P2	E0010-A-240
0K75-1P2	
1K50-1P2	E0020-A-240
2K20-1P2	E0025-A-240
0K40-3P4	E0025-A-480
0K75-3P4	
1K50-3P4	
2K20-3P4	
3K00-3P4	
4K00-3P4	
5K50-3P4	E0036-A-480
7K50-3P4	
11K0-3P4	E0050-A-480
15K0-3P4	
18K5-3P4	E0066-A-480

Tab. 15-2: External EMC filter type



- For definition of model or type, see [chapter 19.2 "Appendix II: Type Coding"](#) on page 248.
- The EMC filters listed above are recommended based on tests with 50 m motor cables. If longer motor cables are needed, please use appropriate EMC filters.
- Only mount the EMC filter FENF vertically. Keep at least 80 mm above the top and below the bottom of the EMC filter free from mounted parts.

15.2.2 Technical Data

Dimensions

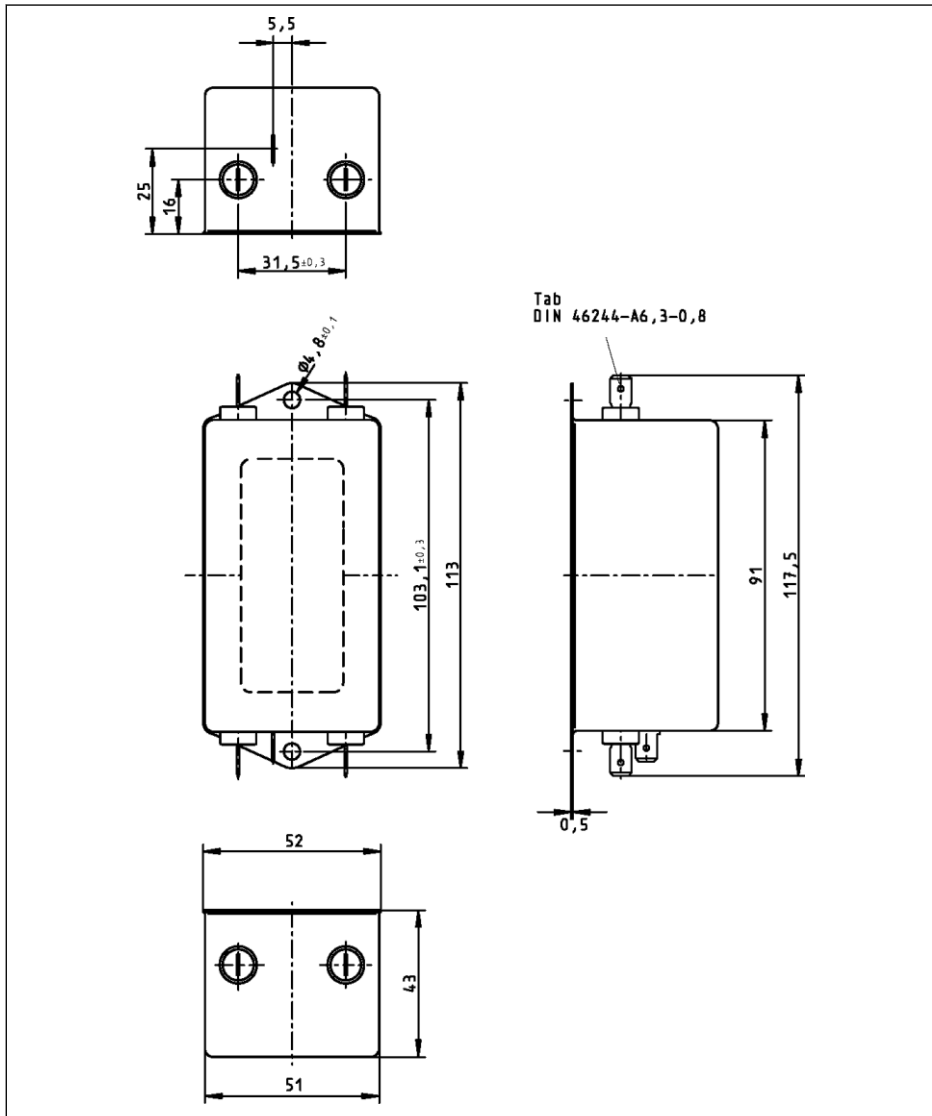

Fig. 15-1: E0010-A-240

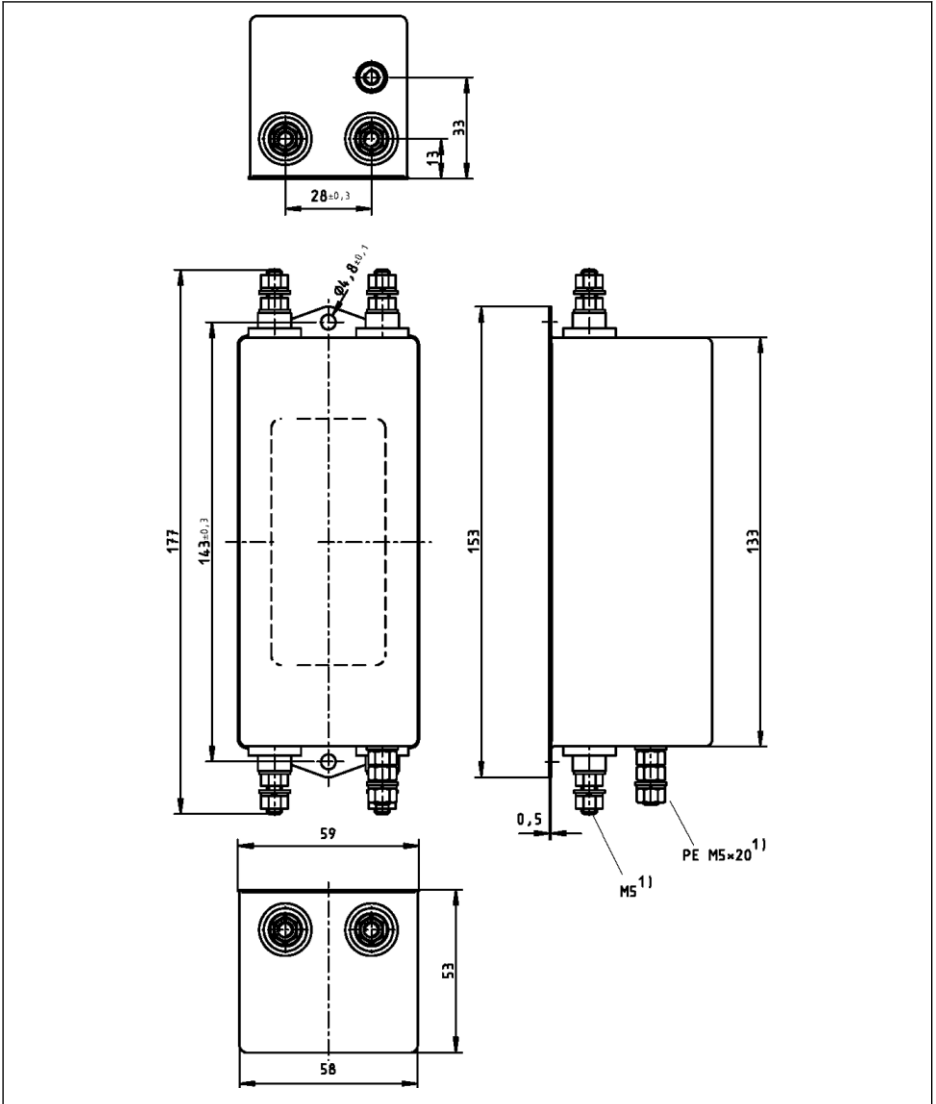

Fig. 15-2: E0020-A-240_E0025-A-240

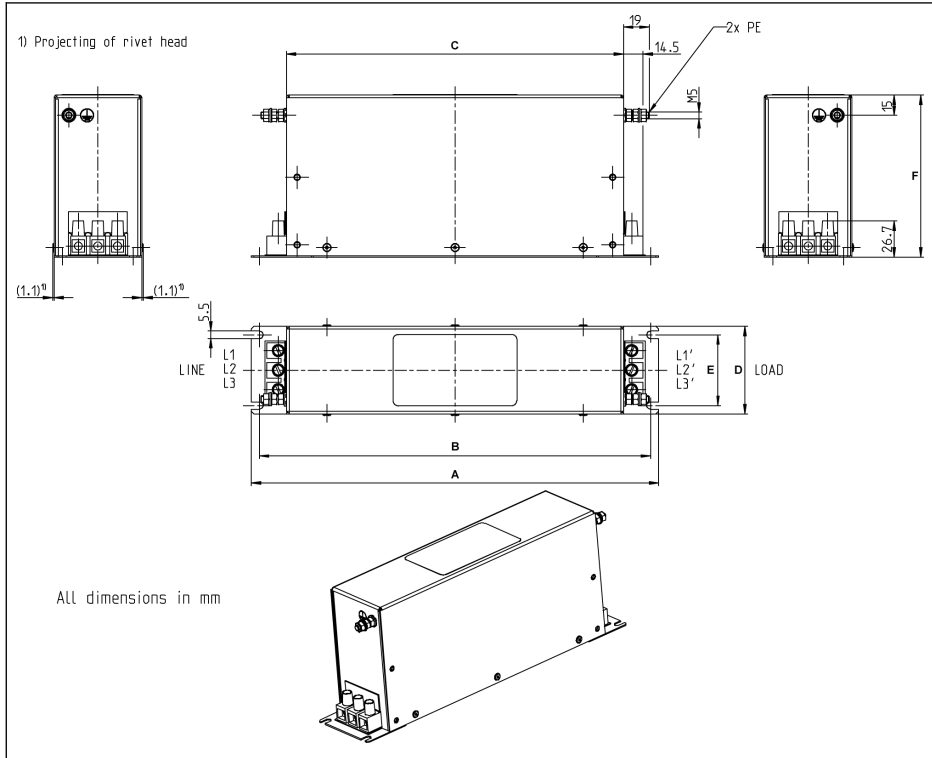

Fig. 15-3: E025-A-480

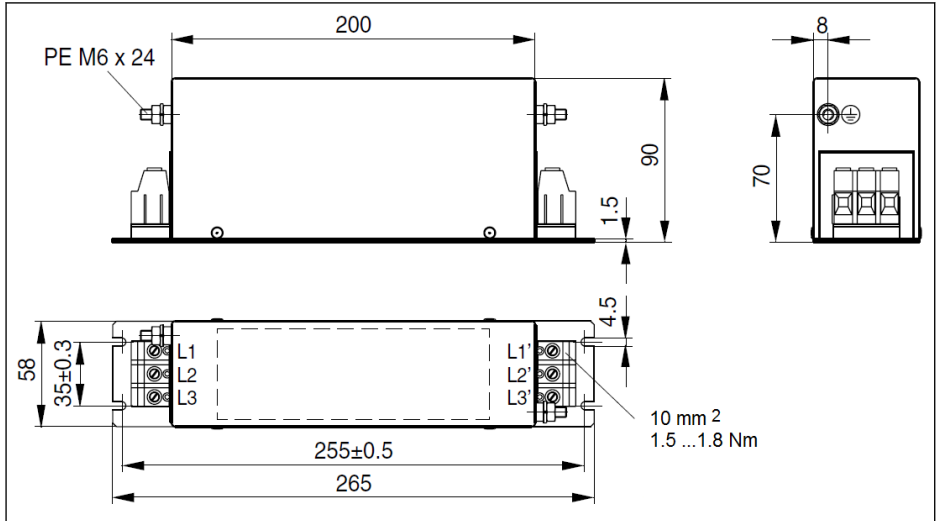

Fig. 15-4: E0036-A-480, E0050-A-480

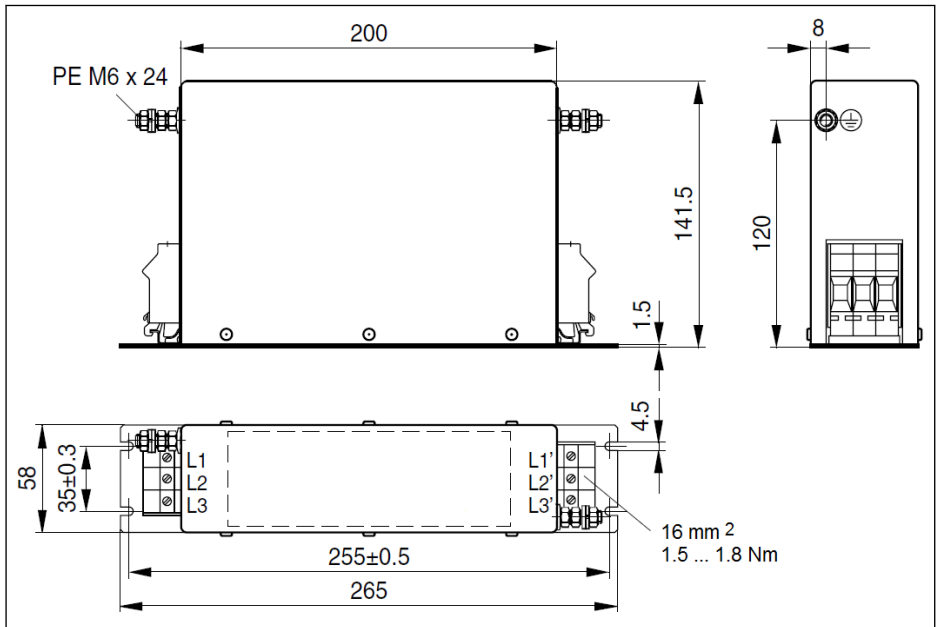

Fig. 15-5: E0066-A-480

Electric data

Electric data of EMC filter for 1P 200 VAC models



When using EMC filters in **mains grounded via outer conductor**, use an isolating transformer between mains and EMC filter.

Description	Symbol	Unit	E0010-A-240	E0020-A-240	E0025-A-240
Degree of protection according to IEC 60529	-	-	IP 20		
Listing according to UL standard (UL)	-	-	UL 1283		
Listing according to CSA standard (UL)	-	-	C22.2 No.8		
Mass (weight)	m	kg	0.42	0.86	0.87
Mains voltage at TN-S, TN-C, TT mains	U_{LN}	V	200...240		
Mains voltage at Corner-grounded-Delta mains	U_{LN}	V	Not allowed		
Mains voltage at IT mains	U_{LN}	V	Not allowed		
Tolerance U_{LN} (UL)	-	-	-10...+10 %		
Input frequency (UL)	f_{LN}	Hz	50...60		
Nominal current	I_{L_cont}	A	10	20	25
Calculation of leakage current	I_{leak}	mA	< 0.5	< 3.5	< 3.5
Required wire size according to IEC 60364-5-52; at I_{L_cont}	A_{LN}	mm ²	2	3.5	5.3
Required wire size according to UL 508 A (internal wiring); at I_{L_cont} (UL)	A_{LN}	AWG	14	12	10

Tab. 15-3: 1P 200 VAC electric data

Electric data of EMC filter for 3P 400 VAC models

Description	Symbol	Unit	E0025 -A-480	E0036 -A-480	E0050 -A-480	E0066 -A-480
Degree of protection according to IEC 60529	–	–	IP 20			
Listing according to UL standard (UL)	–	–	UL 1283			
Listing according to CSA standard (UL)	–	–	C22.2 No.8			
Mass (weight)	m	kg	1.1	1.75	1.75	2.70
Mains voltage three-phase at TN-S, TN-C, TT mains	U_{LN}	V	380...480			
Mains voltage three-phase at Corner-grounded-Delta mains	U_{LN}	V	Not allowed			
Mains voltage three-phase at IT mains	U_{LN}	V	Not allowed			
Tolerance U_{LN} (UL)	–	–	-15...+10 %			
Input frequency (UL)	f_{LN}	Hz	50...60			
Nominal current	I_{Lcont}	A	25	36	50	66
Calculation of leakage current	I_{leak}	mA	15	15	15	16
Required wire size according to IEC 60364-5-52; at I_{Lcont}	A_{LN}	mm ²	5	10	10	16
Required wire size according to UL 508 A (internal wiring); at I_{Lcont} (UL)	A_{LN}	AWG	10	6	6	6 (2)

Tab. 15-4: 3P 400 VAC electric data

15.3 External Brake Resistor

15.3.1 Braking Ratio

Brake resistors with different power ratings are available to dissipate braking energy when the frequency converter is in generator mode.

The tables below list the optimal combination of frequency converter, brake resistor and the number of components required to operate one frequency converter with respect to a given moderating ratio OT.

$$OT = \frac{T_b}{T_c} * 100\%$$

OT (On Time percentage) Braking ratio
T_b Braking time

T_c

Engineering cycle
time in application

Fig. 15-6: Braking ratio

15.3.2 Brake Resistor Selection for Braking Ratio of 10 %**1P 200 VAC**

Converter model	Brake resistor	
	Specification	Number
0K40	400 Ω / 60 W	1
0K75	190 Ω / 100 W	1
1K50	95 Ω / 200 W	1
2K20	65 Ω / 300 W	1

Tab. 15-5: 1P 200 VAC with braking ratio of 10 %**3P 400 VAC**

Converter model	Brake resistor	
	Specification	Number
0K40	750 Ω / 80 W	1
0K75	750 Ω / 80 W	1
1K50	400 Ω / 260 W	1
2K20	250 Ω / 260 W	1
3K00	150 Ω / 390 W	1
4K00	150 Ω / 390 W	1
5K50	75 Ω / 780 W	1
7K50	75 Ω / 780 W	1
11K0	40 Ω / 1,560 W	1
15K0	40 Ω / 1,560 W	1
18K5	32 Ω / 4,800 W	1

Tab. 15-6: 3P 400 VAC with braking ratio of 10 %

15.3.3 Brake Resistor Selection for Braking Ratio of 20 %

1P 200 VAC

Converter model	Brake resistor	
	Specification	Number
0K40	400 Ω / 100 W	1
0K75	190 Ω / 200 W	1
1K50	95 Ω / 400 W	1
2K20	65 Ω / 500 W	1

Tab. 15-7: 1P 200 VAC with braking ratio of 20 %

3P 400 VAC

Converter model	Brake resistor	
	Specification	Number
0K40	750 Ω / 150 W	1
0K75	750 Ω / 150 W	1
1K50	350 Ω / 520 W	1
2K20	230 Ω / 520 W	1
3K00	140 Ω / 780 W	1
4K00	140 Ω / 780 W	1
5K50	70 Ω / 1,560 W	1
7K50	70 Ω / 1,560 W	1
11K0	47 Ω / 2,000 W	1
15K0	34 Ω / 3,000 W	1
18K5	28 Ω / 10,000 W	1

Tab. 15-8: 3P 400 VAC with braking ratio of 20 %

15.4 Shielded Cable Connector

The shielding layer of shielded cables must be reliably connected to the shielding terminals of the frequency converter. Accessories (a connector and two screws) for shielded cable connection are available for the connection convenience.

Dimensions and connection figure

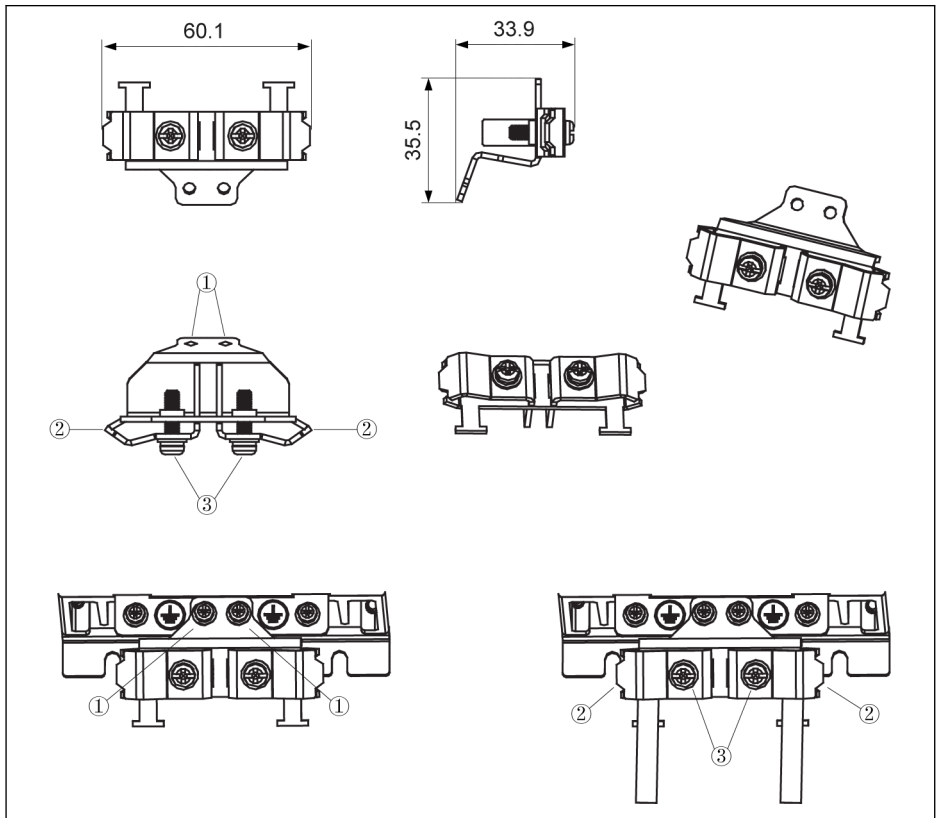

Fig. 15-7: Shielded cable connection with accessories for OK40...4K00

Connection steps

Step 1: Place component ① of the connector on the two screw holes inside of symbols ⊕ and ⊖ and tighten the screws.

Step 2: Insert the shielded cables through component ② of the connector with the shielding layer reliable contact with the metal.

Step 3: Tighten two screws of the accessories (component ③).

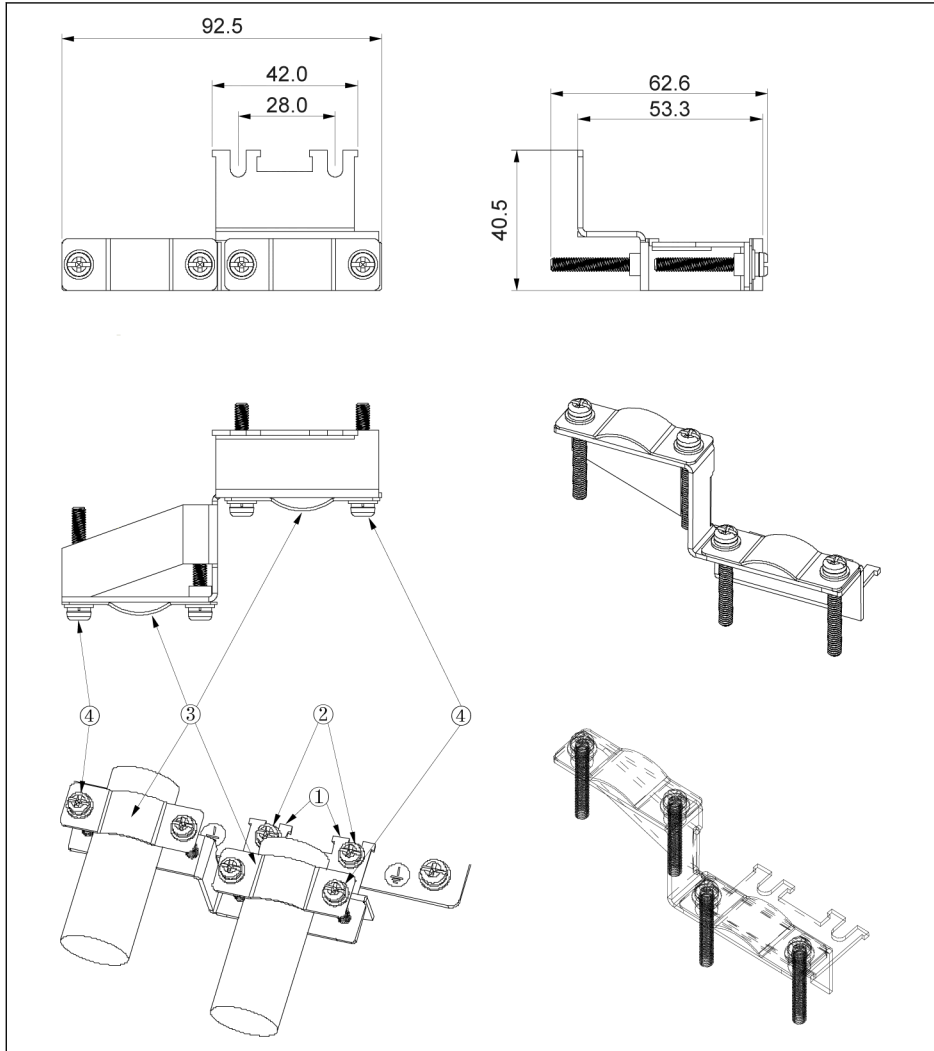

Fig. 15-8: Shielded cable connection with accessories for 5K50...18K5

Connection steps

Step 1: Place component ① of the connector on the two screw holes inside of symbols ⊕ and ⊖ and tighten the screws (component ②: M4 x 12).

Step 2: Insert the shielded cables through component ③ of the connector with the shielding layer reliable contact with the metal.

Step 3: Tighten four screws of the accessories (component ④: M4 x 45).

15.5 Panel Mounting Plate

15.5.1 Function Description

With the operating panel mounted at the control cabinet, the user can operate and control the frequency converter from the outside of the control cabinet conveniently. To realize this function, the user needs order the panel mounting plate and its accessories additionally.

15.5.2 Recommended Opening Dimensions at Control Cabinet

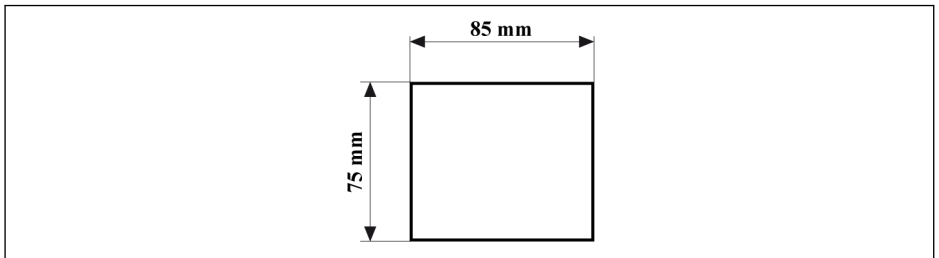

Fig. 15-9: Recommended opening dimensions at control cabinet

15.5.3 Mounting the Plate and the Operating Panel

Step 1

Push the mounting plate into the opening at the control cabinet:

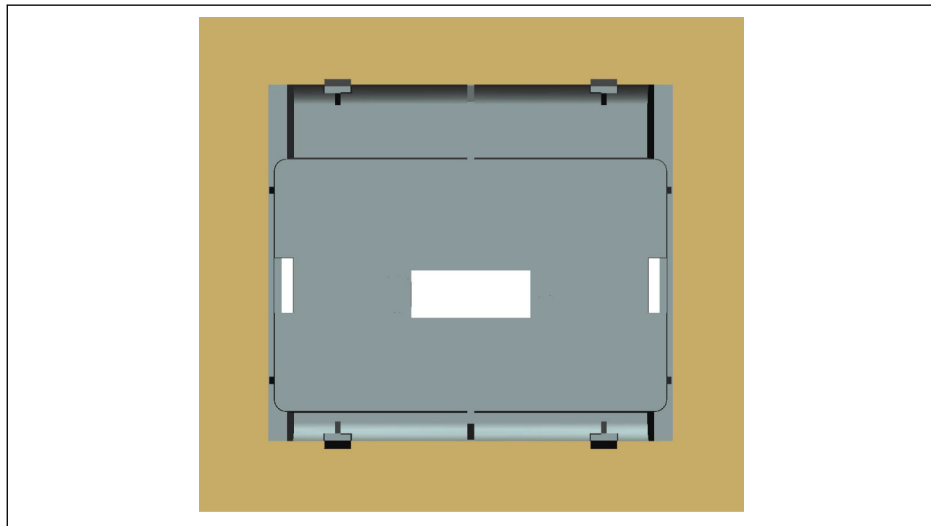

Fig. 15-10: Push the mounting plate into the opening (back view)

Step 2

Fix the mounting plate with a metal bar and 2 M4x8 screws:

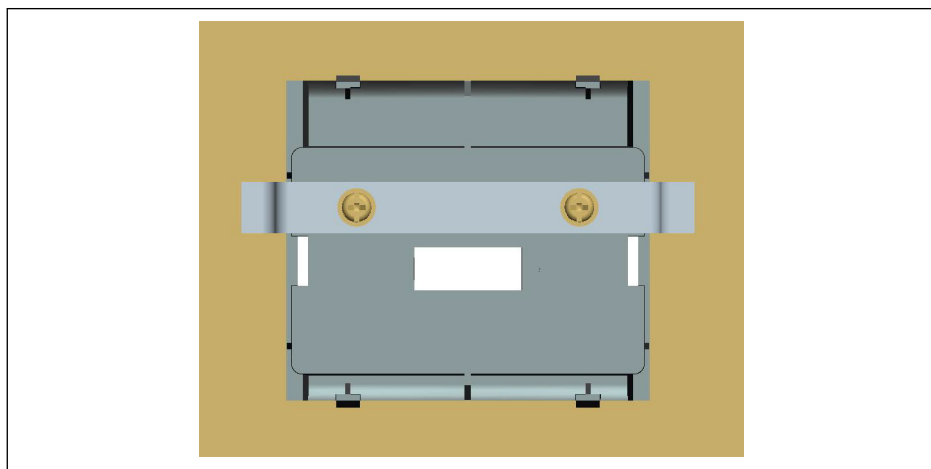

Fig. 15-11: Fix the mounting plate (back view)

Step 3

Push the operating panel in the direction perpendicular to the mounting plate:



Fig. 15-12: Mount the operating panel (front view)

Step 4

Connect the operating panel to the frequency converter with the connection cable and fix the cable connector on the mounting plate with 2 M3x10 screws:

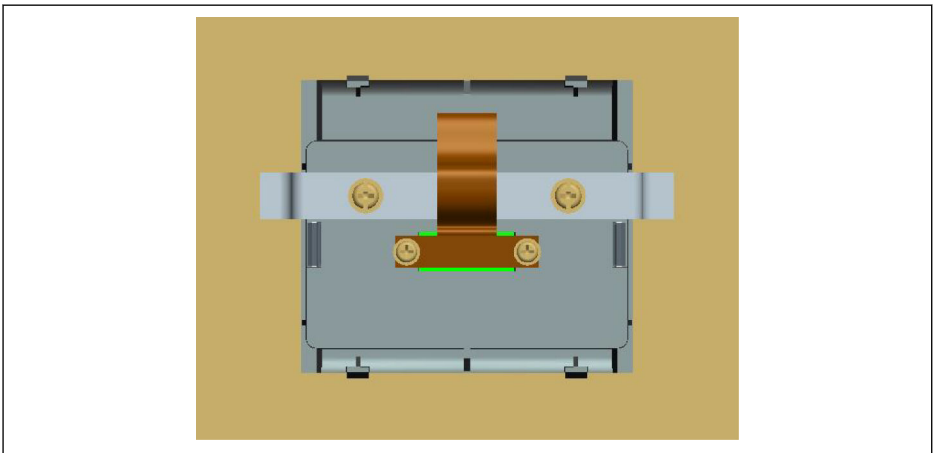

Fig. 15-13: Connect and fix the cable (back view)

15.6 Communication Cable for Control Cabinet

2 m long cable FRKS0006/002,0 or 3 m long cable FRKS0004/003,0 can be used for the connection of the operating panel.

16 Maintenance

16.1 Safety Instructions

WARNING

High electric voltage! Risk of death or severe bodily injury by electric shock!

- Only those trained and qualified to work with or on electric equipment are permitted to operate, maintain and repair this equipment.
- Do not operate electric equipment at any time, even for brief measurements or tests, if the equipment grounding conductor is not permanently connected to the mounting points of the components provided for this purpose.
- Before working with electric parts with voltage potentials higher than 50 V, the device must be disconnected from the mains voltage. Ensure that the mains voltage is not reconnected.
- In the frequency converters, capacitors are used in the DC bus as energy stores. Energy stores maintain their energy even when the supply voltage has been cut off. Frequency converters have been dimensioned in such a way that after the supply voltage was cut off, the voltage value falls below 50 V within a discharging time of a maximum of 5 minutes.

16.2 Daily Inspection

Please conduct daily inspection as indicated in the table below in order to prolong the life cycle of frequency converters.

Inspection category	Inspection item	Inspection criteria	Inspection result
Ambient conditions	Temperature	-10...55 °C (no frost or condensation)	
	Relative humidity	≤ 90 % (no condensation)	
	Dust, water and leakage	No heavy dust or sign of leakage (visual inspection)	
	Gas	No strange smell	
	Sound	No strange sound	
	Panel display	No error code	
Converter	Fan	No blockage or contamination	
Motor	Sound	No strange sound	

Tab. 16-1: Daily inspection list

16.3 Periodic Inspection

In addition to daily inspection, periodic inspection of frequency converters is also necessary. The inspection cycle should be less than 6 months. For operation details, please see table below:

Inspection category	Inspection item	Inspection criteria	Solution
Power supply	Voltage	Specified in nameplate	1P: 200...240 VAC (-10 % / +10 %) 3P: 380...480 VAC (-15 % / +10 %)
Power cable	Power cable	No color change or damage	Replace cable
Signal line	Signal line		Replace signal line
Terminal connection	Crimp terminal and cable / line	No loose connection	Tighten crimp and terminal screw
	Crimp terminal and terminal block		
Frequency converter	Visual appearance	No deformation	Contact with service
	Fan	No color change or deformation	Replace fan
		No blockage or contamination	Eliminate blockage and clean fan
	Cooling system (radiator, inlet, outlet)	No blockage or foreign matters	Eliminate blockage and clear foreign matters
	Printed circuit board	No dust or oil contamination	Clean printed circuit board
DC bus capacitor	No leakage, color change, crack or expansion with safety valve shut down	Replace DC bus capacitor (must be operated by service engineers)	
Accessories	Connection	No loose connection	Tighten terminal screw
	Cable	No color change or damage	Replace cable

Tab. 16-2: Periodic inspection list

16.4 Removable Components Maintenance

16.4.1 Construction Overview

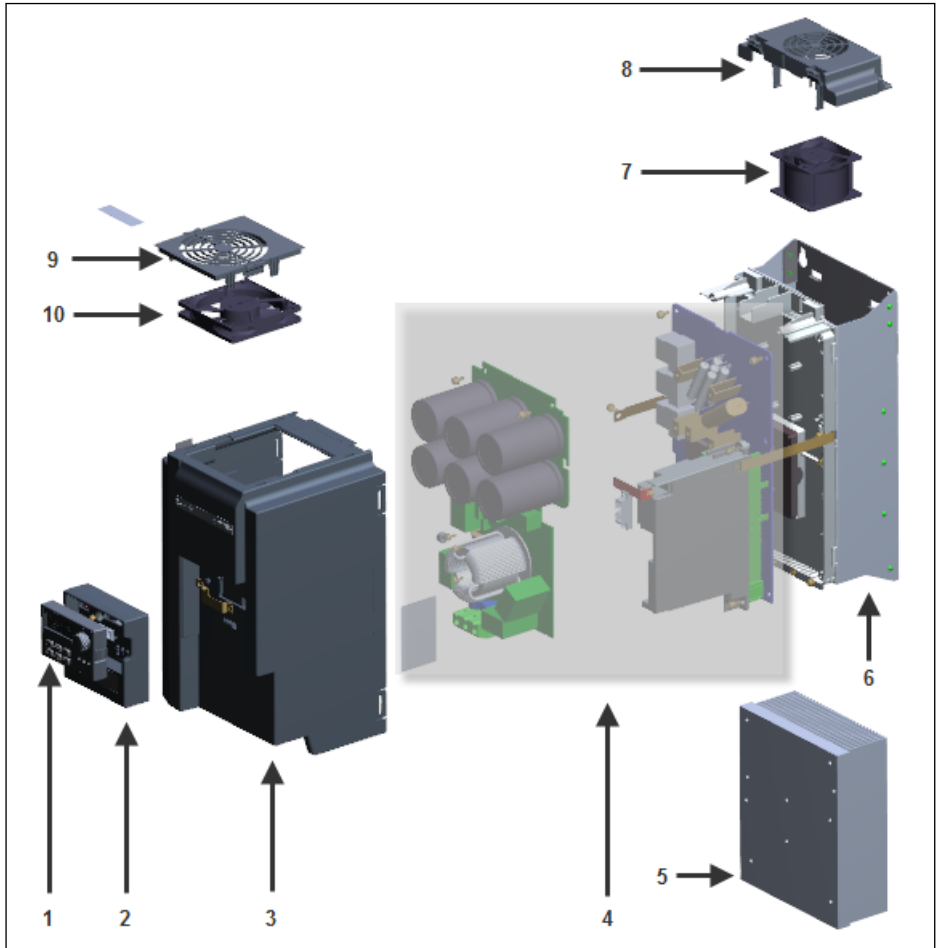

- | | |
|---|--|
| <ul style="list-style-type: none"> 1 Operating panel 2 I/O interface adapter 3 Housing / Frame 4 Internal components 5 Heat sink / Radiator | <ul style="list-style-type: none"> 6 Heat sink mounting plate 7 Back fan / Fan for heat sink 8 Back fan cover 9 Front fan cover 10 Front fan / Fan for internal components |
|---|--|

Fig. 16-1: Construction overview

16.4.2 Disassembly of the Operating Panel

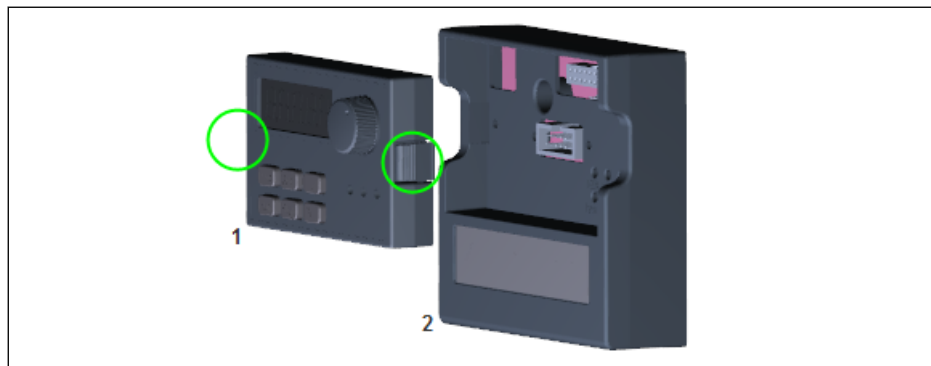

Fig. 16-2: Disassembly of operating panel

- Step 1: Press two buckles as circles indicating in the above figure
- Step 2: Hold component 1 and pull it out horizontally from component 2

16.4.3 Disassembly of Fans

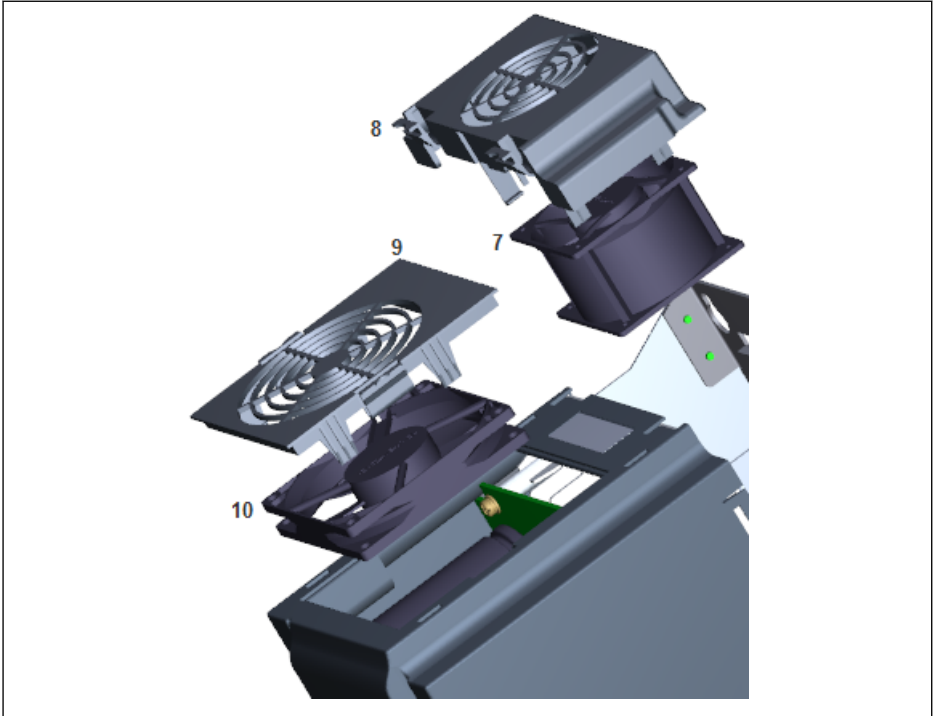

Fig. 16-3: Disassembly of fan

- Step 1: Press the buckle(s) on component 8 or 9 in the above figure
- Step 2: Hold component 8 or 9 and lift it up
- Step 3: Pull out component 7 or 10 slowly
- Step 4: Disconnect the cable connector of component 7 or 10

17 Service and support

Our worldwide service network provides an optimized and efficient support. Our experts offer you advice and assistance should you have any queries. You can contact us **24/7**.

Service Germany

Our technology-oriented Competence Center in Lohr, Germany, is responsible for all your service-related queries for electric drive and controls.

Contact the **Service Helpdesk & Hotline** under:

Phone:	+49 9352 40 5060
Fax:	+49 9352 18 4941
E-mail:	service.svc@boschrexroth.de
Internet:	http://www.boschrexroth.com

Additional information on service, repair (e.g. delivery addresses) and training can be found on our internet sites.

Service worldwide

Outside Germany, please contact your local service office first. For hotline numbers, refer to the sales office addresses on the internet.

Preparing information

To be able to help you more quickly and efficiently, please have the following information ready:

- Detailed description of malfunction and circumstances resulting in the malfunction
- Type plate name of the affected products, in particular type codes and serial numbers
- Your contact data (phone and fax number as well as your email address)

18 Environmental protection and disposal

18.1 Environmental protection

Production processes

The products are made with energy- and resource-optimized production processes which allow re-using and recycling the resulting waste. We regularly try to replace pollutant-loaded raw materials and supplies by more environment-friendly alternatives.

No release of hazardous substances

Our products do not contain any hazardous substances which may be released in the case of appropriate use. Normally, our products will not have any negative influences on the environment.

Significant components

Basically, our products contain the following components:

Electronic devices

- steel
- aluminum
- copper
- synthetic materials
- electronic components and modules

Motors

- steel
- aluminum
- copper
- brass
- magnetic materials
- electronic components and modules

18.2 Disposal

Return of products

Our products can be returned to our premises free of charge for disposal. It is a precondition, however, that the products are free of oil, grease or other dirt.

Furthermore, the products returned for disposal must not contain any undue foreign material or foreign components.

Send the products "free domicile" to the following address:

Bosch Rexroth AG
Electric Drives and Controls
Buergermeister-Dr.-Nebel-Strasse 2
97816 Lohr am Main, Germany

Packaging

The packaging materials consist of cardboard, wood and polystyrene. These materials can be recycled anywhere without any problem.

For ecological reasons, please refrain from returning the empty packages to us.

Batteries and accumulators

Batteries and accumulators can be labeled with this symbol.



The symbol indicating "separate collection" for all batteries and accumulators is the crossed-out wheeled bin.

The end user within the EU is legally obligated to return used batteries. Outside the validity of the EU Directive 2006/66/EC keep the stipulated directives.

Used batteries can contain hazardous substances, which can harm the environment or the people's health when they are improperly stored or disposed of.

After use, the batteries or accumulators contained in Rexroth products have to be properly disposed of according to the country-specific collection.

Recycling

Most of the products can be recycled due to their high content of metal. In order to recycle the metal in the best possible way, the products must be disassembled into individual modules.

Metals contained in electric and electronic modules can also be recycled by means of special separation processes.

Products made of plastics can contain flame retardants. These plastic parts are labeled according to EN ISO 1043. They have to be recycled separately or disposed of according to the valid legal requirements.

19 Appendix

19.1 Appendix I: Abbreviations

- EFC x610: Frequency Converter EFC 3610 or EFC 5610
- FPCC: Operating panel
- FENF: External EMC filter
- FSAM: Panel mounting plate
- FRKS: Communication cable for control cabinet
- FSWA: Engineering software

19.2 Appendix II: Type Coding

19.2.1 Frequency Converter Type Coding

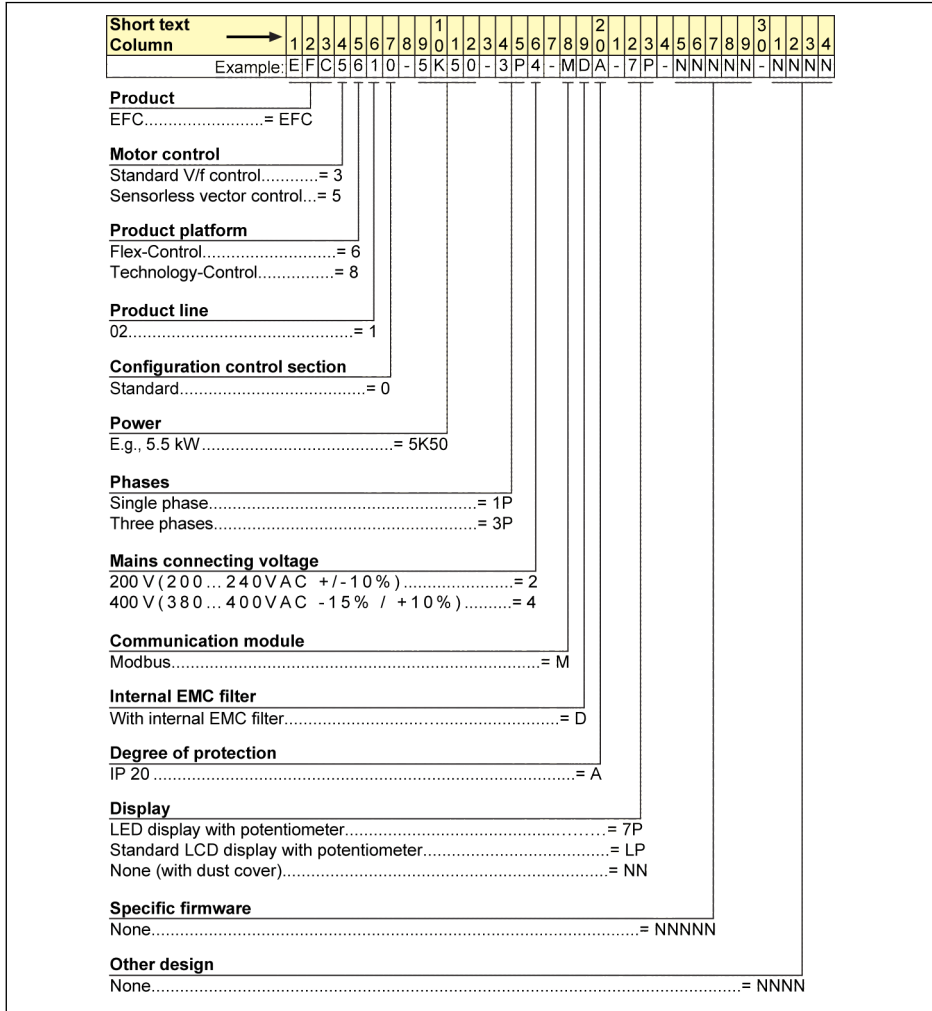

Fig. 19-1: Frequency converter type coding

19.2.2 Operating Panel Type Coding

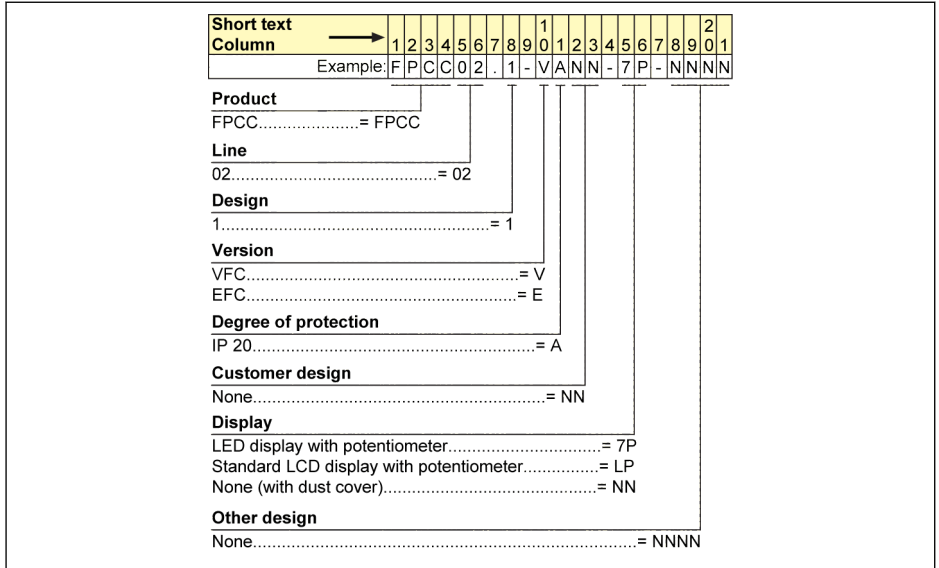

Fig. 19-2: Operating panel type coding

19.2.3 External EMC Filter Type Coding

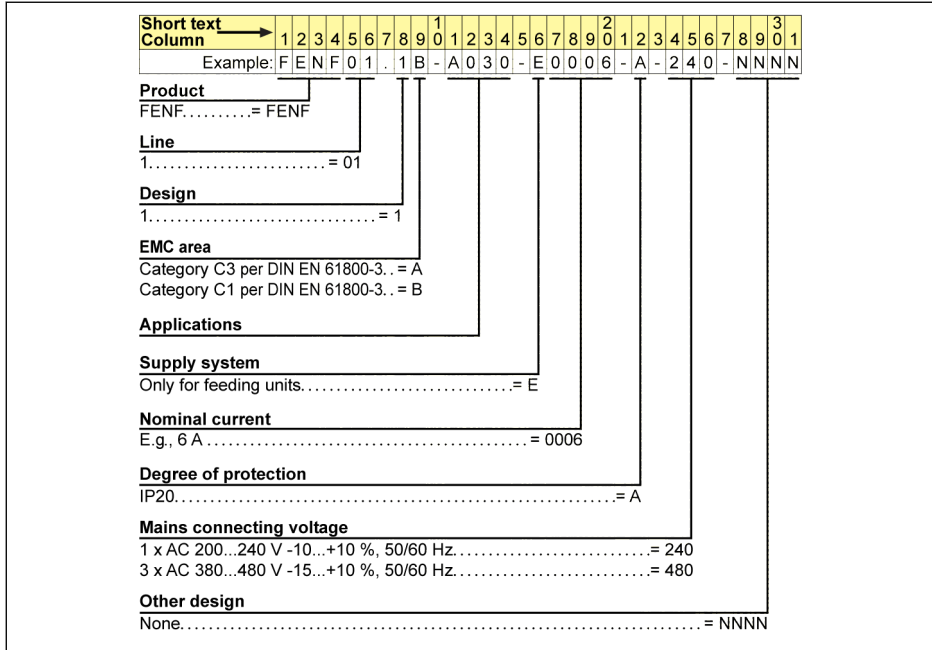

Fig. 19-3: External EMC filter type coding

19.2.4 Panel Mounting Plate Type Coding

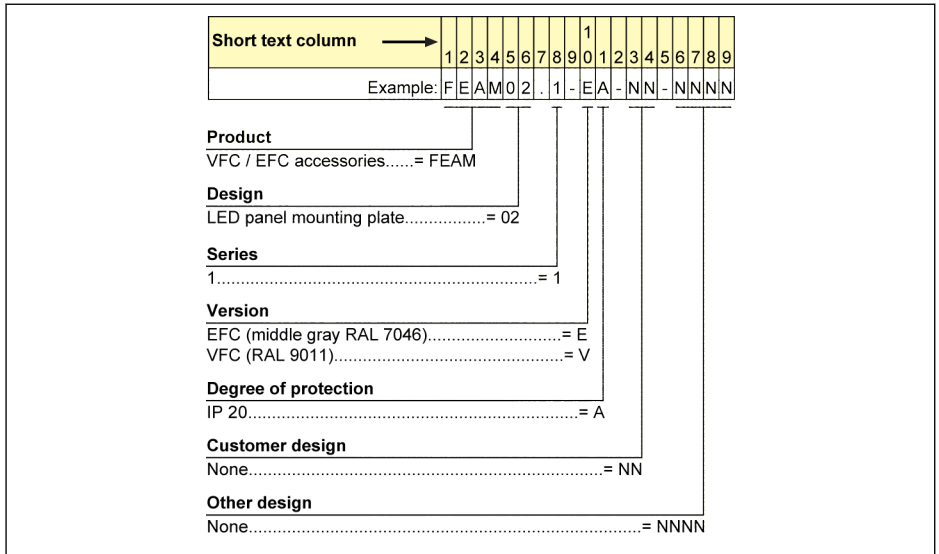

Fig. 19-4: Panel mounting plate type coding

19.2.5 Communication Cable for Control Cabinet Type Coding

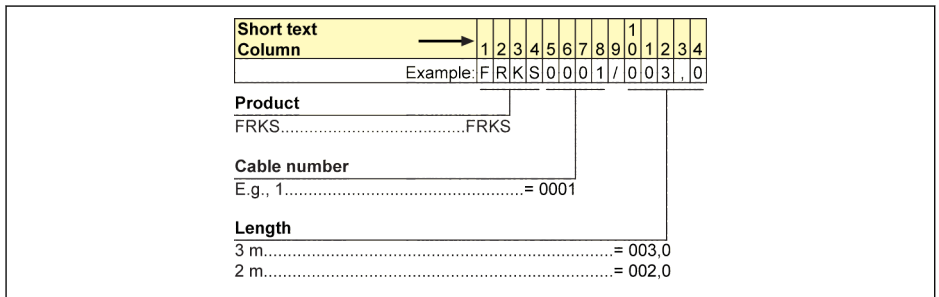

Fig. 19-5: Communication cable for control cabinet type coding

19.2.6 Engineering Software Type Coding

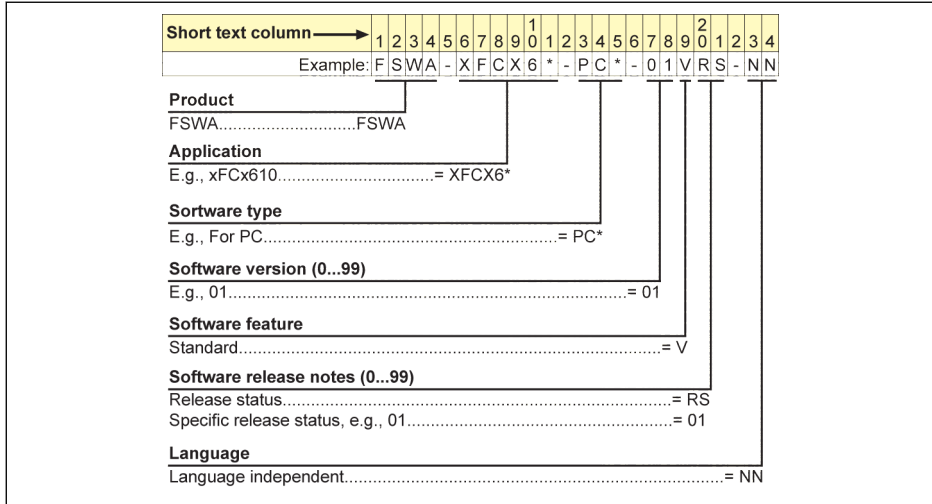

Fig. 19-6: Engineering software type coding

19.3 Appendix III: Parameter List

19.3.1 Terminology and Abbreviation in Parameter List

- **Code:** Function / parameter code, written in bx.xx, Cx.xx, Ex.xx, Ux.xx, dx.xx...
- **Name:** Parameter name
- **Default:** Factory default
- **Min.:** Minimum setting step
- **Attri.:** Parameter attribute
 - **Run:** Parameter setting can be modified when the converter is in run or stop status.
 - **Stop:** Parameter setting can only be modified when the converter is in stop status.
 - **Read:** Parameter setting is read-only and cannot be modified.
- **DOM:** Depends on model
- **[bx.xx], [Cx.xx], [Ex.xx], [Ux.xx], [dx.xx]...:** Function / parameter values

19.3.2 Group b: System Parameters

b0: Basic system parameters

Code	Name	Setting range	Default	Min.	Attri.
b0.00	Access authority setting	0: Basic parameters 1: Standard parameters 2: Advanced parameters 3: Start-up parameters 4: Modified parameters	0	–	Run
b0.10	Parameter initialization	0: Inactive 1: Restore to default settings 2: Clear error record	0	–	Stop
b0.11	Parameter replication	0: Inactive 1: Backup parameters to panel 2: Restore parameters from panel	0	–	Stop
b0.20	User password	0...65,535	0	1	Run
b0.21	Manufacturer password	0...65,535	0	1	Stop

19.3.3 Group C: Power Parameters

C0: Power control parameters

Code	Name	Setting range	Default	Min.	Attri.
C0.00	Control mode (EFC 5610 only)	0: V/f control 1: Sensorless vector control	0	-	Stop
C0.01	Normal / Heavy duty setting (EFC 3610 only)	0: ND (Normal duty) 1: HD (Heavy duty)	1	-	Stop
C0.05	Carrier frequency	1...15 kHz	ND: 4 HD: 6	1	Run
C0.06	Carrier frequency automatic adjustment	0: Inactive; 1: Active	0	-	Stop
C0.15	Braking start point	1P 200 VAC: 300...390 V	390	1	Stop
		3P 400 VAC: 600...785 V	770		
C0.16	Braking duty cycle	1...100 %	100	1	Stop
C0.17	Braking testing	0: Inactive; 1: Active	0	-	Stop
C0.25	Overvoltage prevention mode	0...2	0	-	Stop
C0.26	Stall overvoltage prevention level	1P 200 VAC: 300...390 V	390	1	Stop
		3P 400 VAC: 600...785 V	770		
C0.27	Stall overcurrent prevention level	20.0 %...[C2.42]	200.0	0.1	Stop
C0.28	Phase loss protection mode	0...3	3	-	Run
C0.29	Converter overload pre-warning level	20.0...200.0 %	110.0	0.1	Stop
C0.30	Converter overload pre-warning delay	0.0...20.0 s	2.0	0.1	Stop
C0.40	Power fault ride-through setting	0: Inactive 1: Output disable	0	-	Stop
C0.50	Fan control	0: Automatically controlled 1: Always on	0	-	Run
C0.51	Fan total running time	0...65,535 h	0	1	Read
C0.52	Fan maintenance time	0...65,535 h (0: Inactive)	0	1	Stop
C0.53	Fan total running time reset	0: Inactive; 1: Active Reset to '0' after action is executed	0	-	Run

Setting range of C0.25:

0: Both disabled

- 1: Stall overvoltage protection enabled, resistor braking disabled
- 2: Stall overvoltage protection disabled, resistor braking enabled

Setting range of C0.28:

- 0: Both input and output phase loss protection active
- 1: Only input phase loss protection active
- 2: Only output phase loss protection active
- 3: Both input and output phase loss protection inactive

C1: Motor and system parameters

Code	Name	Setting range	Default	Min.	Attri.
C1.00	Motor type	0: Asynchronous motor	0	–	Stop
C1.01	Motor parameter tuning	0: Inactive 1: Static auto-tuning 2: Rotational auto-tuning [Ⓢ]	0	–	Stop
C1.05	Motor rated power	0.1...1,000.0 kW	DOM	0.1	Stop
C1.06	Motor rated voltage	0...480 V	DOM	1	Stop
C1.07	Motor rated current	0.01...655.00 A	DOM	0.01	Stop
C1.08	Motor rated frequency	5.00...400.00 Hz	50.00	0.01	Stop
C1.09	Motor rated speed	1...30,000 rpm	DOM	1	Stop
C1.10	Motor rated power factor	0.00: Automatically identified 0.01...0.99: Power factor setting	0.00	0.01	Stop
C1.11	Motor poles [Ⓢ]	2...128	DOM	1	Stop
C1.12	Motor rated slip frequency	0.00...20.00 Hz	DOM	0.01	Run
C1.13	Motor inertia mantissa [Ⓢ]	1...5,000	DOM	1	Stop
C1.14	Motor inertia exponent [Ⓢ]	0...7	DOM	1	Stop
C1.20	Motor no-load current	0.00...[C1.07] A	DOM	0.01	Stop
C1.21	Stator resistance	0.00...50.00 Ω	DOM	0.01	Stop
C1.22	Rotor resistance	0.00...50.00 Ω	DOM	0.01	Stop
C1.23	Leakage inductance	0.00...200.00 mH	DOM	0.01	Stop
C1.24	Mutual inductance	0.0...3,000.0 mH	DOM	0.1	Stop
C1.69	Motor thermal model protection setting	0: Inactive 1: Active	1	–	Stop
C1.70	Motor overload pre-warning level	100.0...250.0 %	100.0	0.1	Run
C1.71	Motor overload pre-warning delay	0.0...20.0 s	2.0	0.1	Run
C1.72	Motor sensor type	0: PTC; 2: PT100	0	–	Stop
C1.73	Motor protection level	0.0...10.0	2.0	0.1	Stop
C1.74	Motor thermal protection time constant	0.0...400.0 min	DOM	0.1	Stop
C1.75	Low speed derating frequency	0.10...300.00 Hz	25.00	0.01	Run
C1.76	Zero speed load	25.0...100.0 %	25.0	0.1	Run



[Ⓢ]: ONLY for EFC 5610, and motor load must be decoupled before rotational auto-tuning.

C2: V/f control parameters

Code	Name	Setting range	Default	Min.	Attri.
C2.00	V/f curve mode	0: Linear mode 1: Square curve 2: User-defined curve	0	-	Stop
C2.01	V/f frequency 1	0.00...[C2.03] Hz	0.00	0.01	Stop
C2.02	V/f voltage 1	0.0...120.0 %	0.0	0.1	Stop
C2.03	V/f frequency 2	[C2.01]...[C2.05] Hz	0.00	0.01	Stop
C2.04	V/f voltage 2	0.0...120.0 %	0.0	0.1	Stop
C2.05	V/f frequency 3	[C2.03]...[E0.08] Hz	0.00	0.01	Stop
C2.06	V/f voltage 3	0.0...120.0 %	0.0	0.1	Stop
C2.07	Slip compensation factor	0...200 %	0	1	Run
C2.21	Torque boost mode	0.0 %: Automatic boost 0.1...20.0 %: Manual boost	0.0	0.1	Run
C2.22	Torque boost factor	0...320 %	50	1	Run
C2.23	Heavy load stabilization setting	0: Inactive 1: Active	1	-	Run
C2.24	Light load oscillation damping factor	0...5,000 %	0	1	Run
C2.25	Light load oscillation damping filter factor	10...2,000 %	100	1	Run
C2.40	Current limitation mode	0: Always inactive 1: Inactive at constant speed 2: Active at constant speed	0	-	Stop
C2.42	Current limitation level	[C0.27]...250 %	200	1	Stop
C2.43	Current limitation proportional factor	0.000...10.000	DOM	0.001	Stop
C2.44	Current limitation integral time	0.001...10.000	DOM	0.001	Stop

C3: Vector control parameters

Code	Name	Setting range	Default	Min.	Attri.
C3.00	Speed loop proportional gain	0.00...655.35	DOM	0.01	Run
C3.01	Speed loop integral time	0.01...655.35	DOM	0.01	Run
C3.05	Current loop proportional gain	0.1...1,000.0	DOM	0.1	Run
C3.06	Current loop integral time	0.01...655.35	DOM	0.01	Run
C3.20	Low speed torque limitation factor	1...200 %	100	1	Stop
C3.40	Torque control mode	0: Activated by X1...X5 input 1: Always active	0	1	Stop
C3.41	Torque control reference	0: AI1 1: AI2 2: Panel potentiometer	0	1	Stop
C3.42	Torque reference minimum value	0.0%...[C3.43]	0.0	0.1	Run
C3.43	Torque reference maximum value	[C3.42]...200.0 %	150.0	0.1	Run
C3.44	Torque positive limit	0.0...200.0 %	150.0	0.1	Run
C3.45	Torque negative limit	0.0...200.0 %	150.0	0.1	Run



All parameters in Group C3 are **ONLY** for EFC 5610.

19.3.4 Group E: Function Control Parameters

E0: Set point and control parameters

Code	Name	Setting range	Default	Min.	Attri.
E0.00	First frequency setting source	0...21	0	–	Stop
E0.01	First run command source	0...2	0	–	Stop
E0.02	Second frequency setting source	0...21	2	–	Stop
E0.03	Second run command source	0...2	1	–	Stop
E0.04	Frequency setting source combination	0...2	0	–	Stop
E0.06	Digital setting frequency saving mode	0...3	0	–	Stop
E0.07	Digital setting frequency	0.00...[E0.09] Hz	50.00	0.01	Run
E0.08	Maximum output frequency	50.00...400.00 Hz	50.00	0.01	Stop
E0.09	Output frequency high limit	[E0.10]...[E0.08] Hz	50.00	0.01	Run
E0.10	Output frequency low limit	0.00...[E0.09] Hz	0.00	0.01	Run
E0.15	Low speed running mode	0: Run with 0 Hz 1: Run with low limit frequency	0	–	Stop
E0.16	Low speed frequency hysteresis	0.00...[E0.10] Hz	0.00	0.01	Stop
E0.17	Direction control	0: Forward / Reverse 1: Forward only 2: Reverse only 3: Swap default direction	0	–	Stop
E0.18	Direction change dead time	0.0...60.0 s	1.0	0.1	Stop
E0.25	Acceleration / deceleration curve mode	0: Linear mode 1: S-curve	0	–	Stop
E0.26	Acceleration time	0.1...6,000.0 s	5.0	0.1	Run
E0.27	Deceleration time	0.1...6,000.0 s	5.0	0.1	Run
E0.28	S-curve starting phase factor	0.0...40.0 %	20.0	0.1	Stop
E0.29	S-curve stopping phase factor	0.0...40.0 %	20.0	0.1	Stop
E0.35	Start mode	0: Start directly 1: DC-braking before start 2: Start with speed capture 3: Automatic start / stop according to setting frequency	0	–	Stop
E0.36	Start frequency	0.00...50.00 Hz	0.05	0.01	Stop

Code	Name	Setting range	Default	Min.	Attri.
E0.37	Start frequency holding time	0.0...20.0 s	0.1	0.1	Stop
E0.38	Start DC-braking time	0.0...20.0 s (0.0: Inactive)	0.0	0.1	Stop
E0.39	Start DC-braking current	0.0...150.0 %	0.0	0.1	Stop
E0.41	Automatic start / stop frequency threshold	0.01...[E0.09] Hz	16.00	0.01	Stop
E0.45	Power loss restart	0: Inactive; 1: Active	0	-	Stop
E0.46	Power loss restart delay	0.0...10.0 s	1.0	0.1	Stop
E0.50	Stop mode	0: Decelerating stop 1: Freewheeling stop 2: Freewheeling with stop command, decelerating with direction change	0	-	Stop
E0.52	Stop DC-braking initial frequency	0.00...50.00 Hz	0.00	0.01	Stop
E0.53	Stop DC-braking time	0.0...20.0 s (0.0: Inactive)	0.0	0.1	Stop
E0.54	Stop DC-braking current	0.0...150.0 %	0.0	0.1	Stop
E0.55	Overexcitation braking factor	1.00...1.40	1.10	0.01	Run
E0.60	Jog frequency	0.00...[E0.08] Hz	5.00	0.01	Run
E0.61	Jog acceleration time	0.1...6,000.0 s	5.0	0.1	Run
E0.62	Jog deceleration time	0.1...6,000.0 s	5.0	0.1	Run
E0.70	Skip frequency 1	0.00...[E0.09] Hz	0.00	0.01	Stop
E0.71	Skip frequency 2	0.00...[E0.09] Hz	0.00	0.01	Stop
E0.72	Skip frequency 3	0.00...[E0.09] Hz	0.00	0.01	Stop
E0.73	Skip frequency range	0.00...30.00 Hz	0.00	0.01	Stop
E0.74	Skip window acceleration factor	1...100	1	1	Stop

Setting range of E0.00, E0.02:

- 0: Panel potentiometer
- 1: Panel button setting
- 2: AI1 analog input
- 3: AI2 analog input
- 10: X5 pulse input
- 11: Digital input Up / Down command
- 20: Communication
- 21: Multi-speed settings

Setting range of E0.01, E0.03:

0: Panel

1: Multi-function digital input

2: Communication

Setting range of E0.04:

0: No combination

1: First frequency setting + second frequency setting

2: First frequency setting - second frequency setting

Setting range of E0.06:

0: Not saved when powered off or stopped

1: Not saved when powered off; saved when stopped

2: Saved when powered off; not saved when stopped

3: Saved when powered off or stopped

E1: Input terminal parameters

Code	Name	Setting range	Default	Min.	Attri.
E1.00	X1 input	0...41	0	-	Stop
...	...				
E1.03	X4 input				
E1.04	X5 input	0...47	0	-	Stop
E1.15	2-wire / 3-wire running control	0...4	0	-	Stop
E1.16	Up / Down terminal change rate	0.10...100.00 Hz/s	1.00	0.01	Run
E1.17	Up / Down terminal initial frequency	0.00...[E0.09] Hz	0.00	0.01	Run
E1.25	Pulse input maximum frequency	0.0...50.0 Hz	50.0	0.1	Run
E1.26	Pulse input filter time	0.000...2.000 s	0.100	0.001	Run
E1.35	AI1 input mode	0: 0...20 mA	2	-	Run
E1.40	AI2 input mode	1: 4...20 mA 2: 0...10 V 3: 0...5 V 4: 2...10 V	1	-	Run
E1.38	AI1 gain	0.00...10.00	1.00	0.01	Run
E1.43	AI2 gain	0.00...10.00	1.00	0.01	Run
E1.60	Motor temperature sensor channel	0: Disabled 1: AI1 analog input 2: AI2 analog input	0	-	Stop
E1.61	Broken wire reaction mode	0: Inactive 1: Warning 2: Error	0	-	Stop
E1.68	Analog setting curve selection	0...7	0	-	Run
E1.69	Analog channel filter time	0.000...2.000 s	0.100	0.001	Run
E1.70	Input curve 1 minimum	0.0 %...[E1.72]	0.0	0.1	Run
E1.71	Input curve 1 minimum value	0.00...[E0.09] Hz	0.00	0.01	Run
E1.72	Input curve 1 maximum	[E1.70]...100.0 %	100.0	0.1	Run
E1.73	Input curve 1 maximum value	0.00...[E0.09] Hz	50.00	0.01	Run
E1.75	Input curve 2 minimum	0.0 %...[E1.77]	0.0	0.1	Run
E1.76	Input curve 2 minimum value	0.00...[E0.09] Hz	0.00	0.01	Run
E1.77	Input curve 2 maximum	[E1.75]...100.0 %	100.0	0.1	Run
E1.78	Input curve 2 maximum value	0.00...[E0.09] Hz	50.00	0.01	Run

Setting range of E1.00...E1.03 (0...41), E1.04 (0...47):

- 0: No function assigned
- 1: Multi-speed control input 1
- 2: Multi-speed control input 2
- 3: Multi-speed control input 3
- 4: Multi-speed control input 4
- 10: Acceleration / deceleration time 1 activation
- 11: Acceleration / deceleration time 2 activation
- 12: Acceleration / deceleration time 3 activation
- 15: Freewheeling stop activation
- 16: Stop DC-braking activation
- 20: Frequency Up command
- 21: Frequency Down command
- 22: Up / Down command reset
- 23: Torque / speed control switch
- 25: 3-wire running control
- 26: Simple PLC stop
- 27: Simple PLC pause
- 30: Second frequency setting source activation
- 31: Second run command source activation
- 32: Error signal N.O. contact input
- 33: Error signal N.C. contact input
- 34: Error reset signal
- 35: Forward running (FWD)
- 36: Reverse running (REV)
- 37: Forward jog; 38: Reverse jog
- 39: Counter input; 40: Counter reset
- 41: PID deactivation
- 47: Pulse input mode activation

Setting range of E1.15:

- 0: 2-wire forward / stop, reverse / stop
- 1: 2-wire forward / reverse, run / stop
- 2: 3-wire control mode 1
- 3: 3-wire control mode 2
- 4: Run / Stop

Setting range of E1.68:

- 0: Curve1 for AI1, curve1 for AI2, curve1 for pulse input
- 1: Curve2 for AI1, curve1 for AI2, curve1 for pulse input
- 2: Curve1 for AI1, curve2 for AI2, curve1 for pulse input
- 3: Curve2 for AI1, curve2 for AI2, curve1 for pulse input
- 4: Curve1 for AI1, curve1 for AI2, curve2 for pulse input
- 5: Curve2 for AI1, curve1 for AI2, curve2 for pulse input
- 6: Curve1 for AI1, curve2 for AI2, curve2 for pulse input
- 7: Curve2 for AI1, curve2 for AI2, curve2 for pulse input

E2: Output terminal parameters

Code	Name	Setting range	Default	Min.	Attri.
E2.01	DO1 output selection	0...20	1	–	Stop
E2.02	DO1 pulse output selection	0: Converter output frequency 1: Converter output voltage 2: Converter output current	0	–	Stop
E2.03	Pulse output maximum frequency	0.1...32.0 kHz	32.0	0.1	Run
E2.15	Relay1 output selection	0...20	1	–	Stop
E2.25	AO1 output mode	0: 0...10 V 1: 0...20 mA	0	–	Run
E2.26	AO1 output selection	0: Running frequency 1: Setting frequency 2: Output current 4: Output voltage 5: Output power 6: Analog input voltage 7: Analog input current 11: Motor temperature sensor power supply	0	–	Run
E2.27	AO1 gain setting	0.00...10.00	1.00	0.01	Run
E2.40	Converter rated voltage for analog output	1P 200...240 VAC	220	1	Stop
		3P 380...480 VAC	380		
E2.50	Output curve 1 minimum	0.0 %...[E2.52]	0.0	0.1	Run
E2.51	Output curve 1 minimum value	0.00...100.00 %	0.00	0.01	Run
E2.52	Output curve 1 maximum	[E2.50]...100.0 %	100.0	0.1	Run
E2.53	Output curve 1 maximum value	0.00...100.00 %	100.00	0.01	Run
E2.70	Frequency detection width	0.00...400.00 Hz	2.50	0.01	Run
E2.71	Frequency detection level FDT1	0.01...400.00 Hz	50.00	0.01	Run
E2.72	Frequency detection level FDT1 width	0.01...[E2.71] Hz	1.00	0.01	Run
E2.73	Frequency detection level FDT2	0.01...400.00 Hz	25.00	0.01	Run
E2.74	Frequency detection level FDT2 width	0.01...[E2.73] Hz	1.00	0.01	Run
E2.80	Counter middle value	0...[E2.81]	0	1	Run
E2.81	Counter target value	[E2.80]...9,999	0	1	Run

Setting range of E2.01 (0...19) and E2.15 (0...18):

- 0: Converter ready
- 1: Converter running
- 2: Converter DC-braking
- 3: Converter running at zero speed
- 4: Speed arrival
- 5: Frequency level detection signal (FDT1)
- 6: Frequency level detection signal (FDT2)
- 7: Simple PLC stage complete
- 8: Simple PLC cycle complete
- 10: Converter undervoltage
- 11: Converter overload pre-warning
- 12: Motor overload pre-warning
- 13: Converter stop by external error
- 14: Converter error
- 15: Converter OK
- 16: Target counter value arrival
- 17: Middle counter value arrival
- 18: PID reference engineering value arrival
- 19: Pulse output mode (only available with DO1 output selection)
- 20: Torque control mode

E3: Multi-speed and simple PLC parameters

Code	Name	Setting range	Default	Min.	Attri.
E3.00	Simple PLC running mode	0: Inactive 1: Stop after selected cycle 2: Continuously cycling 3: Run with last stage after selected cycle	0	-	Stop
E3.01	Simple PLC time multiplier	1...60	1	1	Stop
E3.02	Simple PLC cycle number	1...1,000	1	1	Stop
E3.10	Acceleration time 2	0.1...6,000.0 s	10.0	0.1	Run
E3.11	Deceleration time 2	0.1...6,000.0 s	10.0	0.1	Run
E3.12	Acceleration time 3	0.1...6,000.0 s	10.0	0.1	Run
E3.13	Deceleration time 3	0.1...6,000.0 s	10.0	0.1	Run
E3.14	Acceleration time 4	0.1...6,000.0 s	10.0	0.1	Run
E3.15	Deceleration time 4	0.1...6,000.0 s	10.0	0.1	Run
E3.16	Acceleration time 5	0.1...6,000.0 s	10.0	0.1	Run
E3.17	Deceleration time 5	0.1...6,000.0 s	10.0	0.1	Run
E3.18	Acceleration time 6	0.1...6,000.0 s	10.0	0.1	Run
E3.19	Deceleration time 6	0.1...6,000.0 s	10.0	0.1	Run
E3.20	Acceleration time 7	0.1...6,000.0 s	10.0	0.1	Run
E3.21	Deceleration time 7	0.1...6,000.0 s	10.0	0.1	Run
E3.22	Acceleration time 8	0.1...6,000.0 s	10.0	0.1	Run
E3.23	Deceleration time 8	0.1...6,000.0 s	10.0	0.1	Run
E3.40	Multi-speed frequency 1	0.00...[E0.09] Hz	0.00	0.01	Run
E3.41	Multi-speed frequency 2	0.00...[E0.09] Hz	0.00	0.01	Run
E3.42	Multi-speed frequency 3	0.00...[E0.09] Hz	0.00	0.01	Run
E3.43	Multi-speed frequency 4	0.00...[E0.09] Hz	0.00	0.01	Run
E3.44	Multi-speed frequency 5	0.00...[E0.09] Hz	0.00	0.01	Run
E3.45	Multi-speed frequency 6	0.00...[E0.09] Hz	0.00	0.01	Run
E3.46	Multi-speed frequency 7	0.00...[E0.09] Hz	0.00	0.01	Run
E3.47	Multi-speed frequency 8	0.00...[E0.09] Hz	0.00	0.01	Run
E3.48	Multi-speed frequency 9	0.00...[E0.09] Hz	0.00	0.01	Run
E3.49	Multi-speed frequency 10	0.00...[E0.09] Hz	0.00	0.01	Run
E3.50	Multi-speed frequency 11	0.00...[E0.09] Hz	0.00	0.01	Run
E3.51	Multi-speed frequency 12	0.00...[E0.09] Hz	0.00	0.01	Run
E3.52	Multi-speed frequency 13	0.00...[E0.09] Hz	0.00	0.01	Run

Code	Name	Setting range	Default	Min.	Attri.
E3.53	Multi-speed frequency 14	0.00...[E0.09] Hz	0.00	0.01	Run
E3.54	Multi-speed frequency 15	0.00...[E0.09] Hz	0.00	0.01	Run
E3.60	Stage 0 action		011	-	Stop
E3.62	Stage 1 action	011, 012, 013, 014, 015, 016, 017, 018, 021, 022, 023, 024, 025, 026, 027, 028, 031, 032, 033, 034, 035, 036, 037, 038, 041, 042, 043, 044, 045, 046, 047, 048, 051, 052, 053, 054, 055, 056, 057, 058, 061, 062, 063, 064, 065, 066, 067, 068, 071, 072, 073, 074, 075, 076, 077, 078, 081, 082, 083, 084, 085, 086, 087, 088, 111, 112, 113, 114, 115, 116, 117, 118, 121, 122, 123, 124, 125, 126, 127, 128, 131, 132, 133, 134, 135, 136, 137, 138, 141, 142, 143, 144, 145, 146, 147, 148, 151, 152, 153, 154, 155, 156, 157, 158, 161, 162, 163, 164, 165, 166, 167, 168, 171, 172, 173, 174, 175, 176, 177, 178, 181, 182, 183, 184, 185, 186, 187, 188	011	-	Stop
E3.64	Stage 2 action		011	-	Stop
E3.66	Stage 3 action		011	-	Stop
E3.68	Stage 4 action		011	-	Stop
E3.70	Stage 5 action		011	-	Stop
E3.72	Stage 6 action		011	-	Stop
E3.74	Stage 7 action		011	-	Stop
E3.76	Stage 8 action		011	-	Stop
E3.78	Stage 9 action		011	-	Stop
E3.80	Stage 10 action		011	-	Stop
E3.82	Stage 11 action		011	-	Stop
E3.84	Stage 12 action		011	-	Stop
E3.86	Stage 13 action		011	-	Stop
E3.88	Stage 14 action		011	-	Stop
E3.90	Stage 15 action		011	-	Stop
E3.61	Stage 0 running time	0.0...6,000.0 s	20.0	0.1	Stop
E3.63	Stage 1 running time	0.0...6,000.0 s	20.0	0.1	Stop
E3.65	Stage 2 running time	0.0...6,000.0 s	20.0	0.1	Stop
E3.67	Stage 3 running time	0.0...6,000.0 s	20.0	0.1	Stop
E3.69	Stage 4 running time	0.0...6,000.0 s	20.0	0.1	Stop
E3.71	Stage 5 running time	0.0...6,000.0 s	20.0	0.1	Stop
E3.73	Stage 6 running time	0.0...6,000.0 s	20.0	0.1	Stop
E3.75	Stage 7 running time	0.0...6,000.0 s	20.0	0.1	Stop
E3.77	Stage 8 running time	0.0...6,000.0 s	20.0	0.1	Stop
E3.79	Stage 9 running time	0.0...6,000.0 s	20.0	0.1	Stop
E3.81	Stage 10 running time	0.0...6,000.0 s	20.0	0.1	Stop
E3.83	Stage 11 running time	0.0...6,000.0 s	20.0	0.1	Stop
E3.85	Stage 12 running time	0.0...6,000.0 s	20.0	0.1	Stop
E3.87	Stage 13 running time	0.0...6,000.0 s	20.0	0.1	Stop
E3.89	Stage 14 running time	0.0...6,000.0 s	20.0	0.1	Stop
E3.91	Stage 15 running time	0.0...6,000.0 s	20.0	0.1	Stop

E4: PID control parameters

Code	Name	Setting range	Default	Min.	Attri.
E4.00	PID reference channel	0...9	0	-	Stop
E4.01	PID feedback channel	0: AI1 analog input 1: AI2 analog input 2: X5 pulse input	0	-	Stop
E4.02	PID reference / feedback factor	0.01...100.00	1.00	0.01	Run
E4.03	PID engineering analog reference	0.00...10.00	0.00	0.01	Run
E4.04	PID engineering speed reference	0...30,000 rpm	0	1	Run
E4.15	Proportional gain - P	0.000...10.000	1.500	0.001	Run
E4.16	Integral time - Ti	0.00...100.00 s (0.00: no integral)	0.00	0.01	Run
E4.17	Derivative time - Td	0.00...100.00 s (0.00: no derivative)	0.00	0.01	Run
E4.18	Sampling period - T	0.01...100.00 s	0.50	0.01	Run
E4.30	PID deadband	0.0...20.0 %	2.0	0.1	Run
E4.31	PID regulation mode	0, 1	0	-	Run
E4.32	PID engineering value detection width	0.01...100.00	1.00	0.01	Run

Setting range of E4.00:

- 0: No PID control
- 1: Panel potentiometer
- 2: Panel button setting
- 3: AI1 analog input
- 4: AI2 analog input
- 5: X5 pulse input
- 7: Communication
- 8: PID engineering analog reference [E4.03]
- 9: PID engineering speed reference [E4.04]

Setting range of E4.31:

- 0: Stop integral regulation when frequency arrives at upper / lower limit
- 1: Continue integral regulation when frequency arrives at upper / lower limit

E5: Extended function parameters

Code	Name	Setting range	Default	Min.	Attri.
E5.01	High resolution output current filter time	5...500 ms	40	1	Run
E5.02	User-defined speed scaling factor	0.01...100.00	1.00	0.01	Run
E5.05	Pump dry protection ratio	0.0%...[E5.08]	30.0	0.1	Run
E5.06	Pump dry protection delay	0.0...300.0 s (0.0: Inactive)	0.0	0.1	Run
E5.07	Pump dry protection delay at start-up	0.0...300.0 s	30.0	0.1	Run
E5.08	Pump leakage protection ratio	0.0...100.0%	50.0	0.1	Run
E5.09	Pump leakage protection delay	0.0...600.0 s (0.0: Inactive)	0.0	0.1	Run
E5.10	Pump leakage protection delay at start-up	0.0...600.0 s	60.0	0.1	Run
E5.15	Sleep level	0.00...[E0.09] Hz	0.00	0.01	Run
E5.16	Sleep delay	0.0...3,600.0 s	60.0	0.1	Run
E5.17	Sleep boost time	0.0...3,600.0 s	0.0	0.1	Run
E5.18	Sleep boost amplitude	0.0...100.0%	0.0	0.1	Run
E5.19	Wake up level	0.0...100.0%	0.0	0.1	Run
E5.20	Wake up delay	0.2...60.0 s	0.5	0.1	Run

E8: Standard communication parameters

Code	Name	Setting range	Default	Min.	Attri.
E8.00	Communication protocol	0: Modbus	0	–	Stop
E8.01	Communication error detection time	0.0...60.0 s (0.0: Inactive)	0.0	0.1	Stop
E8.02	Communication error protection mode	0: Freewheeling stop 1: Keep running	1	–	Stop
E8.10	Modbus baud rate	0: 1,200 bps; 1: 2,400 bps 2: 4,800 bps; 3: 9,600 bps 4: 19,200 bps; 5: 38,400 bps	3	–	Stop
E8.11	Modbus data format	0...3	0	–	Stop
E8.12	Modbus local address	1...247	1	1	Stop
E8.13	Modbus level / edge sensitivity selection	0: Level sensitive 1: Edge sensitive	1	–	Stop

Setting range of E8.11:

- 0: N, 8, 1 (1 start bit, 8 data bits, 1 stop bit, no parity)
 1: E, 8, 1 (1 start bit, 8 data bits, 1 stop bit, even parity)
 2: O, 8, 1 (1 start bit, 8 data bits, 1 stop bit, odd parity)
 3: N, 8, 2 (1 start bit, 8 data bits, 2 stop bits, no parity)

E9: Protection and error parameters

Code	Name	Setting range	Default	Min.	Attri.
E9.00	Automatic error reset attempts	0...3 (0: Inactive)	0	–	Stop
E9.01	Automatic error reset interval	2...60 s	10	1	Stop
E9.05	Last error type	–	–	–	Read
E9.06	Second last error type	–	–	–	Read
E9.07	Third last error type	–	–	–	Read
E9.10	Output frequency at last error	–	–	0.01	Read
E9.11	Setting frequency at last error	–	–	0.01	Read
E9.12	Output current at last error	–	–	0.1	Read
E9.13	Output voltage at last error	–	–	1	Read
E9.14	DC-bus voltage at last error	–	–	1	Read
E9.15	Power module temperature at last error	–	–	1	Read

Value range of E9.05...E9.07:

- 0: No error
- 1: OC-1, overcurrent at constant speed
- 2: OC-2, overcurrent during acceleration
- 3: OC-3, overcurrent during deceleration
- 4: OE-1, overvoltage at constant speed
- 5: OE-2, overvoltage during acceleration
- 6: OE-3, overvoltage during deceleration
- 7: OE-4, overvoltage during stop
- 8: UE-1, undervoltage during run
- 9: SC, current surge or short circuit
- 10: IPH.L, input phase loss
- 11: OPH.L, output phase loss
- 12: ESS-, soft start error
- 20: OL-1, converter overload
- 21: OH, converter over temperature
- 22: UH, converter under temperature
- 23: FF, fan failure
- 24: Pdr, pump dry
- 30: OL-2, motor overload
- 31: Ot, motor over temperature
- 32: t-Er, motor parameter tuning error
- 38: AibE, analog input broken wire detection
- 40: dir1, forward running lock error
- 41: dir2, reverse running lock error
- 42: E-St, terminal error signal
- 43: FFE-, firmware version mismatch
- 44: rS-, Modbus communication error
- 50: idE-, converter internal error
- 55: PbrE, parameter backup / restore error

19.3.5 Group U: Panel Parameters

U0: General panel parameters

Code	Name	Setting range	Default	Min.	Attri.
U0.00	Panel control direction	0: Forward 1: Reverse	0	–	Run
U0.01	Stop button mode	0: Active only for panel control 1: Valid for all control methods	1	–	Run

U1: Seven-segment panel parameters

Code	Name	Setting range	Default	Min.	Attri.
U1.00	Run monitoring display	0: Actual output frequency	0	–	Run
		1: Actual speed 2: Setting frequency 3: Setting speed 4: User-defined setting speed 5: User-defined output speed 10: Output voltage 11: Output current 12: Output power 13: DC-bus voltage 16: Output torque 17: Setting torque			
U1.10	Stop monitoring display	20: Power module temperature 21: Actual carrier frequency 23: Power stage running time 30: AI1 input value 31: AI2 input value 40: Digital input status1 45: Digital output status1 50: Pulse input frequency 70: PID reference engineering value 71: PID feedback engineering value 98: High resolution output current 99: Firmware version	2	–	Run

19.3.6 Group d0: Monitoring Parameters

Code	Name	Minimum unit
d0.00	Actual output frequency	0.01 Hz
d0.01	Actual speed	1 rpm
d0.02	Setting frequency	0.01 Hz
d0.03	Setting speed	1 rpm
d0.04	User-defined setting speed	0.1
d0.05	User-defined output speed	0.1
d0.10	Output voltage	1 V
d0.11	Output current	0.1 A
d0.12	Output power	0.1 kW
d0.13	DC-bus voltage	1 V
d0.16	Output torque	0.1 %
d0.17	Setting torque	0.1 %
d0.20	Power module temperature	1 °C
d0.21	Actual carrier frequency	1 kHz
d0.23	Power stage running time	1 h
d0.30	AI1 input value	0.1 V / 0.1 mA
d0.31	AI2 input value	0.1 V / 0.1 mA
d0.40	Digital input status1	–
d0.45	Digital output status1	–
d0.50	Pulse input frequency	0.1 kHz
d0.70	PID reference engineering value	0.1
d0.71	PID feedback engineering value	0.1
d0.98	High resolution output current	0.01 A
d0.99	Firmware version	0.01

19.4 Appendix IV: Certification

19.4.1 CE

Declaration of conformity

For Frequency Converters EFC x610, there are declarations of conformity which confirm that the devices comply with the applicable EN Standards and EC Directives. If required, you may ask our sales representative for the declarations of conformity.

EU directives	Standard
Low-Voltage Directive 2006/95/EC	EN 61800-5-1 (IEC 61800-5-1: 2007)
EMC Directive 2004/108/EC	EN 61800-3 (IEC 61800-3: 2004)

Tab. 19-1: EU directives and standards

CE label



Fig. 19-7: CE label

High-voltage test

According to standard EN 61800-5-1, all EFC x610 components are tested with high voltage.

19.4.2 UL

The frequency converters are listed by UL "Underwriters Laboratories Inc.". You can find the evidence of certification on the Internet under <http://www.ul.com> under "Certifications" by entering the file number or the "Company Name: Rexroth".

UL listing



Fig. 19-8: UL listing

UL standard

UL 508C

Company name

BOSCH REXROTH (XIAN) ELECTRIC DRIVES AND CONTROLS CO., LTD.

Category name

Power Conversion Equipment

File number

E328841

UL ratings

For using the components in the scope of UL, take the UL ratings of the individual component into account.

Make sure that the indicated short circuit rating SCCR is not exceeded (5000 Arms), e.g. by appropriate fuses in the mains supply of the supply unit.

Wiring material UL

In the scope of UL, use only copper conductors rated 75 °C or above.

Requirements for United States / Canadian installations (UL/cUL):

Suitable for use on a circuit capable of delivering not more than 5,000 rms Symmetrical Amperes, 480 VAC maximum, when protected by UL/cUL-certified Class J fuses only. Power cable use 75 °C or above copper wire. This equipment is capable of providing internal motor overload protection according to UL 508C.

For Canadian (cUL) installations the drive mains supply must be fitted with any external recommended suppressor with the following features:

- Surge-protective devices; device shall be a Listed Surge-protective device (Category code VZCA and VZCA7)
- Rated nominal voltage 480/277 VAC, 50/60 Hz, 3-phase
- Clamping voltage VPR = 2,000 V, IN = 3 kA min, MCOV = 508 VAC, SCCR = 5,000 A
- Suitable for Type 2 SPD application
- Clamping shall be provided between phases and also between phase and ground

Notes

Bosch Rexroth AG

Electric Drives and Controls

P.O. Box 13 57

97803 Lohr, Germany

Bgm.-Dr.-Nebel-Str. 2

97816 Lohr, Germany

Tel. +49 9352 40 5060

Fax +49 9352 18 4941

service.svc@boschrexroth.de

www.boschrexroth.com



R912005854