

## IRB 920T/IRB 920

### SCARA robot for high precision assembly



IRB 920T/IRB 920 SCARA robots offer a wide variety of models to fulfill various need for electronics manufacturing applications

Designed to meet the requirements of the electronics industry, the IRB 920T/IRB 920 provides the highest levels of speed, accuracy and repeatability for a range of assembly, picking and handling tasks.

With its class-leading speed and compact design, the IRB 920T/IRB 920 can be installed in a variety of locations to enable fast and cost-effective handling of loads up to 6kg, from single components through to assembled products.

#### Key Benefits

- **Class-leading speed:** Fourteen percent faster than its predecessor, the IRB 910SC, and with a cycle time of 0.31 seconds, the IRB 920T outperforms other SCARA robots in its class, reducing cycle times and enabling more products to be produced per hour.
- **Excellent repeatability:** The IRB 920T/IRB 920's excellent repeatability enables it to achieve the highest levels of manufacturing quality with minimal or zero wastage.
- **Lightweight design:** Weighing just 24kg, the IRB 920T/IRB 920 is 10 percent lighter than other SCARA robots in its class, eliminating the need for extra materials to support the robot, reducing cell design costs. Routing all cables internally to remove cable interference also enables a compact footprint, minimizing installation space requirements.

- **Increased connections:** Option of up to 20 I/O (Input/Output) connectors allows the use of more sophisticated grippers and end effectors for more complex applications.  
\*compared to IRB 910SC
- **Rich configurations:** A choice of 450, 550 and 650mm reach options meet the requirements for a range of different operations. An extended stroke of 300mm supports applications requiring additional vertical reach.
- **Larger diameter air hose:** The use of a larger diameter air hose provides additional power for vacuum suction, making it possible to handle multiple objects simultaneously.

#### Main applications

- Assembly
- Picking/Placing
- Material Handling

## Specification

Robot version	IRB 920T-6/0.45	IRB 920T-6/0.55	IRB 920T-6/0.65	IRB 920-6/0.45	IRB 920-6/0.55	IRB 920-6/0.65
Reach (m)	0.45	0.55	0.65	0.45	0.55	0.65
Payload (kg)				6		
Number of axes				4		
Protection	Standard IP30 <sup>1</sup> , Option IP54			Standard IP30		
Cleanroom	Option ISO5			N/A		
Mounting				Floor		
Controller				OmniCore E10, C30, C90XT		
Integrated signal and power supply				Up to 20 signals <sup>2</sup>		
Integrated air supply				4 air on outer arm (Max. 6 Bar) <sup>2</sup>		
Integrated ethernet				One 1000 Base-T ethernet port <sup>2</sup>		

<sup>1</sup> Ballscrew area: IP20

<sup>2</sup> Optional

## Performance

	IRB 920T-6/0.45	IRB 920T-6/0.55	IRB 920T-6/0.65	IRB 920-6/0.45	IRB 920-6/0.55	IRB 920-6/0.65
1 kg picking cycle 25 x 300 x 25 mm	0.35s	0.31s	0.34s	0.40s	0.41s	0.40s
<b>Performance (according to ISO 9283)</b>						
Pose repeatability, RP	0.01mm	0.02mm	0.02mm	0.01mm	0.02mm	0.01mm
Path repeatability, RT	0.03mm	0.03mm	0.03mm	0.02mm	0.03mm	0.03mm
Pose stabilization time within 0.1mm of the position PST	0.17s	0.17s	0.16s	0.10s	0.17s	0.18s

Given motion pattern with optimized setup

## Physical and movement

	IRB 920T-6/0.45	IRB 920T-6/0.55	IRB 920T-6/0.65	IRB 920-6/0.45	IRB 920-6/0.55	IRB 920-6/0.65
Robot Base	170x193mm					
Robot weight	22kg	23kg	24kg	22kg	23kg	24kg
<b>Working range</b>						
Axis 1 (rotation)	+150° to -150°					
Axis 2 (rotation)	+145° to -145°					
Axis 3 (Z)	-180mm to 0mm; -300mm to 0mm;					
Axis 4 (rotation)	+400° to -400°					
<b>Axis max. speed</b>						
Axis 1 (rotation)	396°/s, 420°/s (E10)			420°/s		
Axis 2 (rotation)	780°/s			701°/s		
Axis 3 (Z)	1.2m/s			1.1m/s		
Axis 4 (rotation)	2500°/s			2500°/s		

## IRB 920T/IRB 920, working range

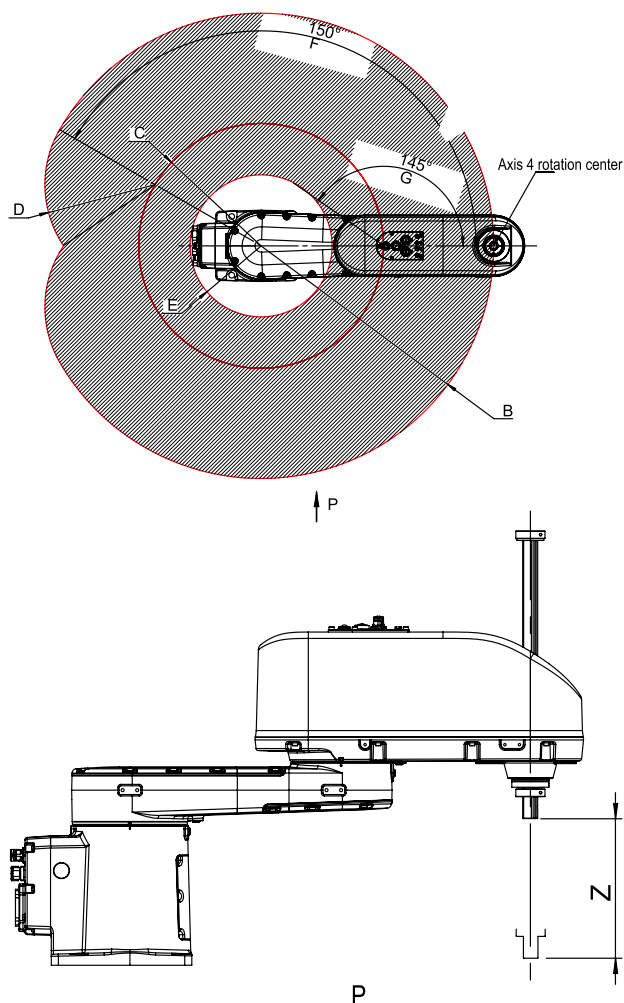

## Working range and dimension

	Z <sup>3</sup> (Axis 3)	B	C	D	E
<b>IRB 920T</b>					
0.45_0.18	180mm	450mm	190mm	260mm	150.9mm
0.45_0.3	300mm	450mm	190mm	260mm	150.9mm
0.55_0.18	180mm	550mm	290mm	260mm	167.8mm
0.55_0.3	300mm	550mm	290mm	260mm	167.8mm
0.65_0.18	180mm	650mm	390mm	260mm	231.5mm
0.65_0.3	300mm	650mm	390mm	260mm	231.5mm
<b>IRB 920</b>					
0.45_0.18	180mm	450mm	190mm	260mm	150.9mm
0.55_0.18	180mm	550mm	290mm	260mm	167.8mm
0.65_0.18	180mm	650mm	390mm	260mm	231.5mm

<sup>3</sup> The Z dimension varies due to option IP54/CR. Please check detail information from Product Specification.