

---

ROBOTICS

# Product specification

## IRB 6710



Trace back information:  
Workspace 26B version a6  
Checked in 2026-06-12  
Skribenta version 5.6.019

## **Product specification**

**IRB 6710-210/2.65**

**IRB 6710-200/2.95**

**IRB 6710-175/2.65 LID**

**IRB 6710-175/2.95 LID**

**OmniCore**

**Document ID: 3HAC085703-001**

**Revision: L**

The information in this manual is subject to change without notice and should not be construed as a commitment by ABB. ABB assumes no responsibility for any errors that may appear in this manual.

Except as may be expressly stated anywhere in this manual, nothing herein shall be construed as any kind of guarantee or warranty by ABB for losses, damage to persons or property, fitness for a specific purpose or the like.

In no event shall ABB be liable for incidental or consequential damages arising from use of this manual and products described herein.

This manual and parts thereof must not be reproduced or copied without ABB's written permission.

Keep for future reference.

Additional copies of this manual may be obtained from ABB.

Original instructions.

© Copyright 2023-2026 ABB. All rights reserved.  
Specifications subject to change without notice.

# Table of contents

Overview of this specification .....	7
<b>1 Description of IRB 6710</b> .....	<b>9</b>
1.1 About the IRB 6710 .....	9
1.2 About the IRB 6710 DressPack .....	13
1.3 Impacting robot lifetime .....	16
1.4 Applicable standards .....	22
1.5 Maintenance and troubleshooting .....	23
<b>2 Technical data for IRB 6710</b> .....	<b>25</b>
2.1 Technical data .....	25
2.1.1 Technical data .....	25
2.1.2 Airborne noise level .....	29
2.1.3 Power consumption .....	30
2.1.4 Working range .....	31
2.1.5 Robot motion .....	38
2.2 Fitting equipment on the robot (robot dimensions) .....	39
2.3 Mechanical data for installation .....	49
2.4 Installing a base plate .....	51
2.5 Working range alterations .....	59
2.5.1 Adjusting the working range .....	59
2.5.2 Installing movable mechanical stops on axis 1 (option 3323-1) .....	61
2.6 Calibration and references .....	63
2.6.1 Calibration methods .....	63
2.6.2 Synchronization marks and synchronization position for axes .....	65
2.6.3 Calibration movement directions for all axes .....	67
2.6.4 Fine calibration .....	68
2.6.5 Calibration tools for Axis Calibration .....	69
2.6.6 Absolute Accuracy calibration .....	70
2.7 Load diagrams .....	72
2.7.1 Introduction .....	72
2.7.2 Diagrams .....	74
2.7.3 Maximum load and moment of inertia for full and limited axis 5 (center line down) movement .....	82
2.7.4 Wrist torque .....	84
2.7.5 Maximum TCP acceleration .....	85
2.8 Performance according to ISO 9283 .....	86
2.9 Velocity .....	87
2.10 Robot stopping distances and times .....	88
2.10.1 Robot stopping distances according to ISO 10218-1 .....	88
2.10.2 Measuring stopping distance and time .....	92
2.10.3 IRB 6710-210/2.65 .....	94
2.10.4 IRB 6710-200/2.95 .....	102
2.10.5 IRB 6710-175/2.65 LID .....	110
2.10.6 IRB 6710-175/2.95 LID .....	118
<b>3 Specification of variants and options</b> .....	<b>127</b>
3.1 Introduction to variants and options .....	127
3.2 Manipulator .....	128
3.3 Floor cables .....	134
3.4 Application .....	135
3.4.1 Overview of DressPack options .....	135
3.4.2 DressPack for material handling .....	136
3.4.3 DressPack for spotwelding .....	142
3.4.4 Configuration result of DressPack options .....	148

## Table of contents

---

3.4.5	Connector kits manipulator .....	151
3.4.5.1	Base - Connector kits .....	151
3.4.5.2	Axis 3 - Connector kits .....	155
3.4.5.3	Axis 6 - Connector kits .....	159
3.4.6	Application floor cables .....	164
3.5	Warranty .....	166
<b>Index</b>		<b>167</b>

---

# Overview of this specification

## About this product specification

This product specification describes the performance of the manipulator or a complete family of manipulators in terms of:

- The structure and dimensional prints
- The fulfilment of standards, safety, and operating equipment
- The load diagrams, mounting or extra equipment, the motion, and the robot reach
- The specification of available variants and options

The specification covers the manipulator using the OmniCore controller.

## Usage

Product specifications are used to find data and performance about the product, for example to decide which product to buy. How to handle the product is described in the product manual.

The specification is intended for:

- Product managers and product personnel
- Sales and marketing personnel
- Order and customer service personnel
- Integrators and customers

## References

Documentation referred to in the product specification, is listed in the table below.

Document name	Document ID
<i>Product manual - IRB 6710</i>	<i>3HAC085695-001</i>
<i>Circuit diagram - IRB 6710/IRB 6720/IRB 6730/IRB 6740/IRB 6760/IRB 6730S/IRB 6750S</i>	<i>3HAC086333-001</i>
<i>Product manual - OmniCore V250XT Type B</i>	<i>3HAC087112-001</i>
<i>Product manual - OmniCore V400XT</i>	<i>3HAC081697-001</i>
<i>Technical reference manual - System parameters (RobotWare 7)</i>	<i>3HAC065041-001</i>
<i>Technical reference manual - System parameters (RobotWare 8)</i>	<i>3HAC098390-001</i>
<i>Application manual - Controller software OmniCore RobotWare 7</i>	<i>3HAC066554-001</i>
<i>Application manual - Controller software OmniCore RobotWare 8</i>	<i>3HAC098393-001</i>



### Tip

All documents can be found via ABB Robotics One, <https://one.robotics.abb.com/en/knowledge-hub>.

Continues on next page

## Revisions

Revision	Description
A	First edition.
B	Published in release 23C. The following updates are done in this revision: <ul style="list-style-type: none"> <li>• Corrected information about available options for forklift device.</li> <li>• Corrected information about available options for DressPack.</li> </ul>
C	Published in release 23D. The following updates are done in this revision: <ul style="list-style-type: none"> <li>• Tool flange dimensions updated.</li> <li>• Added support for OmniCore V400XT.</li> <li>• Corrected the content of the connector kit, <a href="#">Option 3331-1, Weld Proc 2-4 base on page 153</a>.</li> </ul>
D	Published in release 24A. The following updates are made in this revision: <ul style="list-style-type: none"> <li>• Corrected position descriptions for illustrations of DressPack connection plates at axis 3 interface and at the base.</li> </ul>
E	Published in release 24B. The following updates are made in this revision: <ul style="list-style-type: none"> <li>• Added motor cooling as option.</li> <li>• Removed servo connector information for material handling option.</li> <li>• Added DressPack options for EtherCAT.</li> <li>• Added resolver connection to customer connector plate on base.</li> <li>• Changed allowed capacity of the utility power on connector CP at the base.</li> <li>• Added images for DP connector kits.</li> </ul>
F	Published in release 24C. The following updates are made in this revision: <ul style="list-style-type: none"> <li>• Added image of end connectors at axis 6 for DressPack SW.</li> <li>• Added 22 m process cables.</li> </ul>
G	Published in release 24D. The following updates are made in this revision: <ul style="list-style-type: none"> <li>• Minor corrections.</li> </ul>
H	Published in release 25.2. The following updates are made in this revision: <ul style="list-style-type: none"> <li>• Added the section <a href="#">Impacting robot lifetime on page 16</a>.</li> <li>• Updated the installation (mounting) angle for the manipulator.</li> </ul>
J	Published in release 25.3. The following updates are made in this revision: <ul style="list-style-type: none"> <li>• Updated robot dimensions with manipulator base measurement.</li> <li>• Clarified the installation (mounting) angle for the manipulator.</li> <li>• Company name updated to reflect current legal entities.</li> <li>• Updated portal name from myABB to ABB Robotics One.</li> <li>• Cable glands and additional information added in the manipulator connector kits.</li> </ul>
K	Published in release 26.1. The following updates are done in this revision: <ul style="list-style-type: none"> <li>• Added diagram and made other minor updates to section <a href="#">Impacting robot lifetime</a> (previously called <a href="#">Maximizing robot lifetime</a>)</li> <li>• Company name updated to reflect current legal entities.</li> <li>• Added support for RobotWare 8.</li> </ul>
L	Published in release 26B. The following updates are done in this revision: <ul style="list-style-type: none"> <li>• Added drilling pattern for the MH3 gripping clamp at the wrist.</li> </ul>

# 1 Description of IRB 6710

## 1.1 About the IRB 6710

---

### General introduction

ABB is expanding its large size robot portfolio with IRB 6710, offering faster performance, more accurate, expanded mounting options, and advanced foundry protection than other competing robots in its class.

The IRB 6710 is available in four variants spanning various options for payload from 175 kg to 210 kg, reach from 2.65 m to 2.95 m.

---

### Intended use

IRB 6710 is ideal for use in material handling, machine tending, and high precision assembly applications in the Electric Vehicle (EV), automotive, and the general industries. For Electric Vehicles, robots can handle an array of tasks, including EV battery module picking and placing, high precision assembly and parts handling. For general industries, the robots can be used for a wide range of tasks in die casting, material removal, cleaning, spraying and general high precision applications.

See [Impacting robot lifetime on page 16](#).

*Continues on next page*

# 1 Description of IRB 6710

## 1.1 About the IRB 6710

*Continued*

### Available variants

The IRB 6710 is available in the following variants.

#### Variants with standard wrist

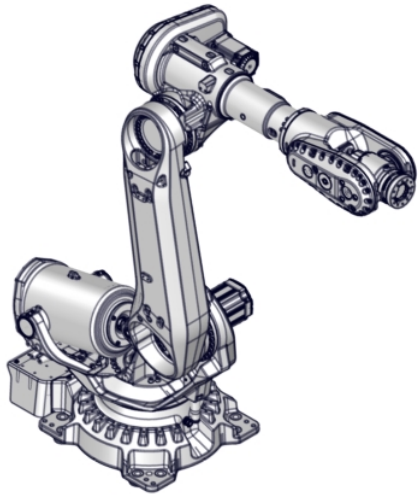
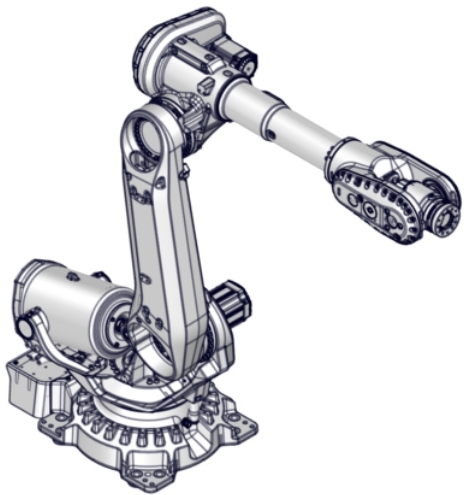
	 xx2200002091	 xx2200002092
Robot variant	IRB 6710-210/2.65	IRB 6710-200/2.95
Handling capacity	210 kg	200 kg
Reach	2.65 m	2.95 m

#### Variants with LeanID

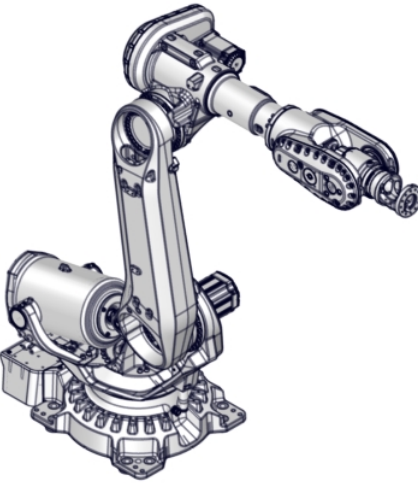
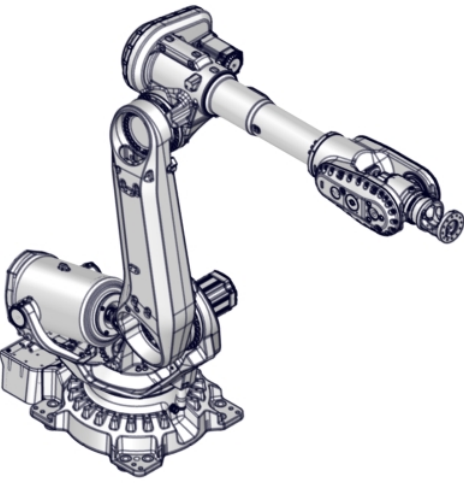
	 xx2200002093	 xx2200002094
Robot variant	IRB 6710-175/2.65 LID	IRB 6710-175/2.95 LID
Handling capacity	175 kg	175 kg
Reach	2.65 m	2.95 m

*Continues on next page*

### Robot axes

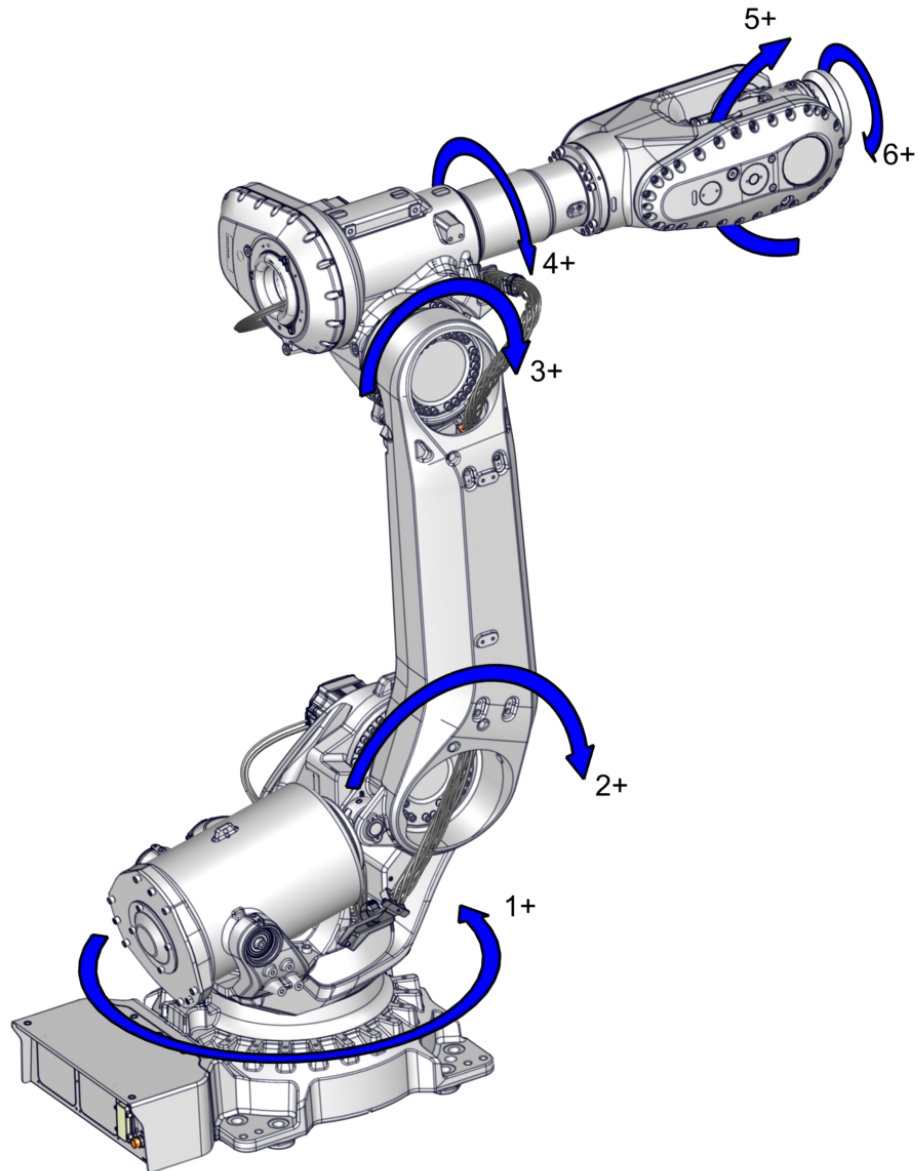

xx2200002089

### Control system

The robot is equipped with the OmniCore controller and robot control software, RobotWare. RobotWare supports every aspect of the robot system, such as motion control, development and execution of application programs, communication etc. See *Operating manual - OmniCore*.

We have added a range of software products - all falling under the umbrella designation of Active Safety - to protect not only personnel in the unlikely event of an accident, but also robot tools, peripheral equipment and the robot itself.

The IRB 6710 manipulator can be connected to the following robot controllers:

- OmniCore V250XT Type B

*Continues on next page*

# 1 Description of IRB 6710

---

## 1.1 About the IRB 6710

*Continued*

- OmniCore V400XT

---

### Safety

Safety standards valid for complete robot, manipulator and controller.

---

### Additional functionality

For additional functionality, the robot can be equipped with optional software for application support - for example communication features - network communication - and advanced functions such as multitasking, sensor control etc. For a complete description on optional software, see the product specification for the robot controller, listed in [References on page 7](#).

### 1.2 About the IRB 6710 DressPack

#### About the DressPack

The IRB 6710 can be equipped with the well-integrated cable and hose packages in the DressPack options. The DressPack is designed together with the manipulator to offer a complete solution. The DressPack is designed to fit a wide variety of applications, and are well integrated into the robot system to ensure long life and large working range.

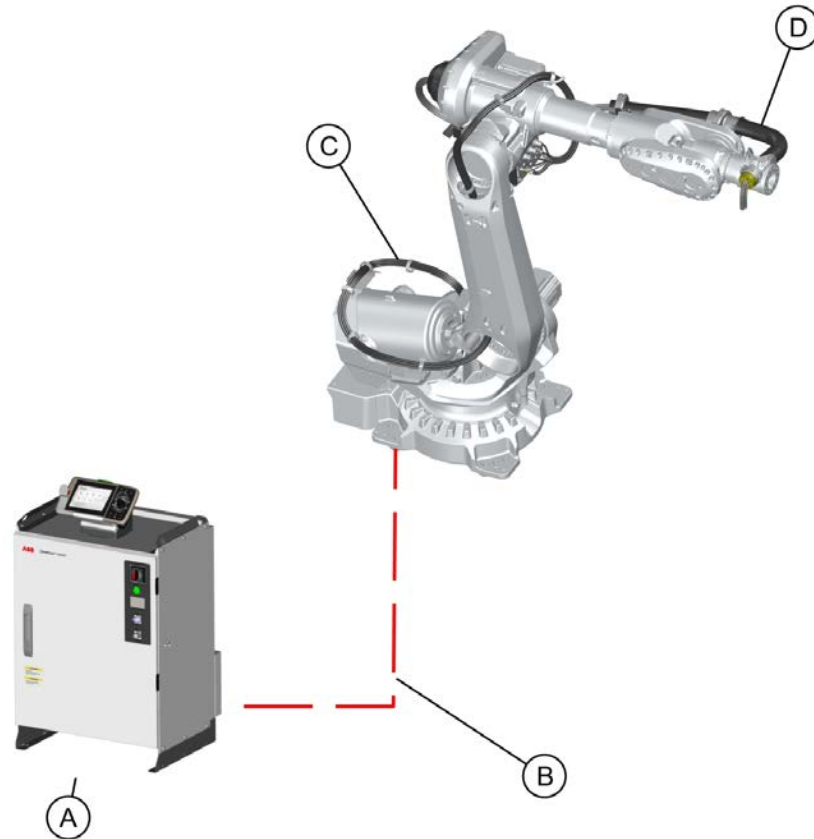

xx230000230

Pos	Description
A	Robot controller
B	DressPack, floor
C	DressPack, lower arm
D	DressPack, upper arm

*Continues on next page*

# 1 Description of IRB 6710

## 1.2 About the IRB 6710 DressPack

*Continued*

### Available DressPack for IRB 6710

To support the variety of complexity in the operation/wrist movements, there are different solutions available.

The lower arm DressPack (base - axis 3) has the same routing and design for all manipulator variants, but differs for material handling and spot welding. The DressPack for material handling (MH) is routed inside the manipulator lower arm while the DressPack for spot welding (SW) runs outside of the lower arm.

The upper arm DressPack options (axis 3 - 6) are available in different design solutions, *LeanID - MH*, *LeanID - SW* and *MH3*. The main difference between *LeanID* and *MH3* is that *LeanID* is guided across the axis 6 center of rotation by utilizing a process turning disc instead of the standard turning disc. This allows for a controlled and predictable motion pattern of the DressPack. The *MH3* DressPack is designed for less complex wrist movements and requires the integrator to manage the DressPack routing at axis 6.

The *LeanID* Empty Conduit is an empty casing without cabling.

Robot variant	DressPack variants	
	Base - axis 3	axis 3 - 6
IRB 6710-210/2.65	MH, SW	MH3
IRB 6710-200/2.95	MH, SW	MH3
IRB 6710-175/2.65 LID	MH, SW	LeanID - MH, LeanID - SW, LeanID Empty Conduit
IRB 6710-175/2.95 LID	MH, SW	LeanID - MH, LeanID - SW, LeanID Empty Conduit

*Continues on next page*

# 1 Description of IRB 6710

## 1.2 About the IRB 6710 DressPack

*Continued*

Illustration of DressPack designs

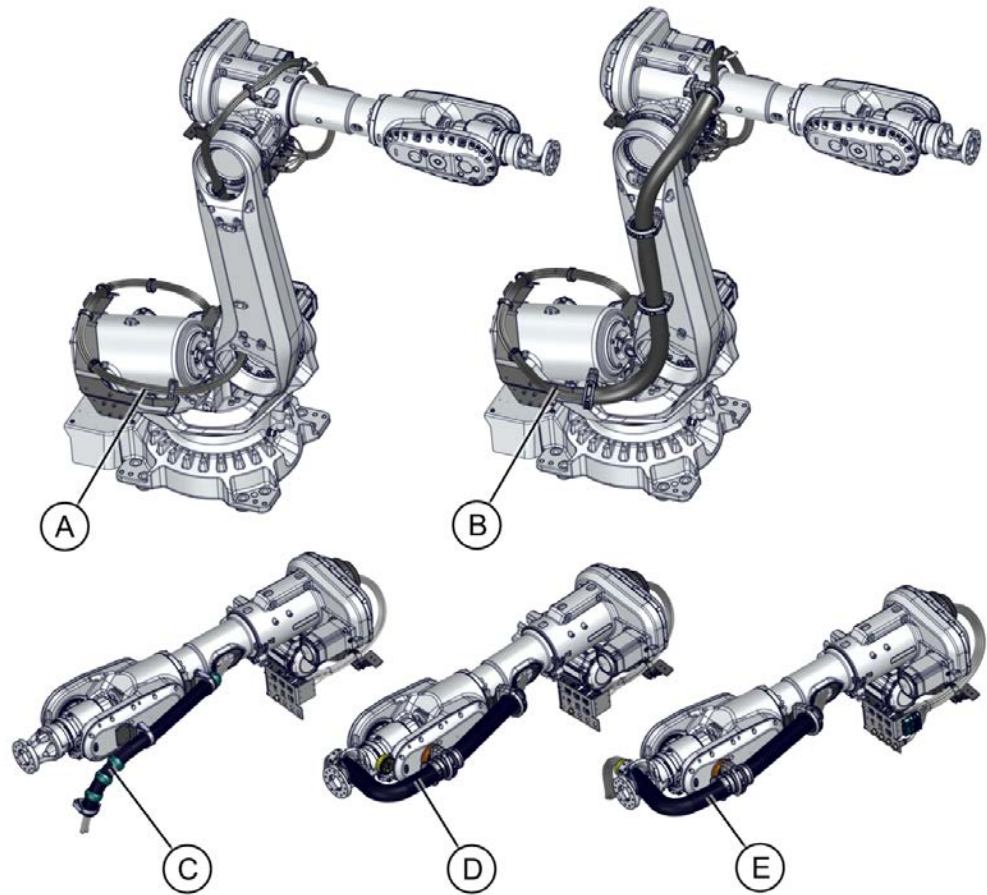

xx230000229

	Description	DressPack variant	Robot variant
A	DressPack base - axis 3	MH	IRB 6710-210/2.65 IRB 6710-200/2.95 IRB 6710-175/2.65 LID IRB 6710-175/2.95 LID
B	DressPack base - axis 3	SW	IRB 6710-210/2.65 IRB 6710-200/2.95 IRB 6710-175/2.65 LID IRB 6710-175/2.95 LID
C	DressPack axis 3 - 6	MH3	IRB 6710-210/2.65 IRB 6710-200/2.95
D	DressPack axis 3 - 6	LeanID - MH	IRB 6710-175/2.65 LID IRB 6710-175/2.95 LID
E	DressPack axis 3 - 6	LeanID - SW	IRB 6710-175/2.65 LID IRB 6710-175/2.95 LID
-	DressPack axis 3 - 6	LeanID Empty Conduit	IRB 6710-175/2.65 LID IRB 6710-175/2.95 LID

# 1 Description of IRB 6710

---

## 1.3 Impacting robot lifetime

### 1.3 Impacting robot lifetime

---

#### Introduction

The expected lifetime of a robot is an important factor when planning an installation. This information is aiming to help you to maximize the lifetime of your robot and avoid unnecessary downtime or repair.

The lifetime of a robot is influenced by the following, but not limited to, factors:

- [Robot type selection on page 16](#)
- [Duty factor on page 16](#)
- [Environmental conditions on page 17](#)
- [Application and usage on page 17](#)
- [Design limitations on page 19](#)
- [Maintenance on page 19](#)
- [Individual lifetime variability on page 19](#)
- [Extreme usage on page 19](#)

---

#### Robot type selection

Selecting the right robot for the application is generally done based on payload and reach criteria, but other factors can influence the selection, such as the duty factor. Selecting the most suitable variant is crucial to achieve the expected high performance, uptime, and lifetime. Always select a robot in accordance with the intended use, see [Intended use on page 9](#).

ABB robots are capable of high accelerations and speeds. It is generally recommended to use RobotStudio to find out if a robot model is suitable for a specific application and duty factor. RobotStudio is an excellent tool to help with the assessment of the duty factor and the selection of the most suitable robot variant.

In the case of intense use of robots, optional cooling fans may be required, and the expected component life of gearboxes and motors may be affected. Contact ABB for cooling fan solution.

This robot is not specifically designed for use in demanding applications with a very high duty factor. If used in such conditions, a significant reduction in lifetime is possible for all axes, depending on the cycle. See [Extreme usage on page 19](#).

When selecting the robot variant, consider using application-specific robot, and suitable protection type.



#### Note

Use the Mechanical Analysis add-in in RobotStudio (see details below) for help with the assessment, or get technical support from ABB.

---

#### Duty factor

Duty factor is the percentage of time the robot is moving divided by the total time, including movement and wait time during the complete robot work cycle. It is a

*Continues on next page*

measurement of how much the robot is being used. Gearbox lifetime is reduced more rapidly by a higher duty cycle than by a lower one. See [Extreme usage on page 19](#).



### Note

The duty factor impact on lifetime can be analyzed in the add-in *Mechanical Analysis* in RobotStudio (see details below) and *Service Information System* (SIS) data in the controller. Contact ABB to analyze the SIS data.

## Environmental conditions

Following factors within environmental conditions of the robot has an impact on the robot lifetime:

- Temperature:

The robot usage at high temperatures or extreme usage can lead to gearbox and motor cooling problems. Observe operating temperature limits stated in manipulator product manual. Extreme usage normally requires means of reduction of motor and gearbox oil heat.

The option to add a cooling fan to some of the axes, will allow the robot to run even with an extreme usage. See the description of the available options in section [Motor cooling on page 132](#).



### Note

The add-in *Mechanical Analysis* in RobotStudio (see details below) or technical support from ABB can provide recommendation on using fans.

- Exposure to chemicals might impact sealings, which can cause oil leakage.
- Vibrations caused by not following the foundation requirements might cause reduction of lifetime, for example for bearings. See [Requirements, foundation on page 27](#).
- Cleaning. Wrong cleaning can cause particles entering the sealings which can cause oil leakage. Proper cleaning is described in *Product manual - IRB 6710*.

## Application and usage

Following factors within robot application and usage has an impact on the robot lifetime:

- Payload definition and overload:

It is important to define the payload within specification and correctly defined tool data. See section [Load diagrams on page 72](#), and *Technical reference manual - RAPID Overview*.

The service routine for load identification, *LoadIdentify*, is available to support tool data definition. See *Operating manual - OmniCore*.

- Acceleration/deceleration:

*Continues on next page*

# 1 Description of IRB 6710

---

## 1.3 Impacting robot lifetime

*Continued*

The gearbox lifetime is reduced more rapidly by high accelerations/decelerations than by lower ones.



### Note

Smother movements bring reduced energy consumption.



### Note

Acceleration/deceleration can be modified with the instruction `AccSet`. See *Technical reference manual - RAPID Overview*.

Acceleration/deceleration is optimized by using automatic path planning functionality, either offline, or in RobotStudio, or using the online software.

- Limited movements:

If the range or the rotation angle for an axis is 10° or less, the expected life of the reduction gears may be reduced due to poor lubrication of internal parts or the internal parts being subject to a concentrated load. Add extra lubrication motion to the robot program or to maintenance schedule.



### Note

Use RobotStudio *Signal Analyzer* or get technical support from ABB. An event message will be displayed on the FlexPendant if a limited movement is detected (RobotWare 7.20 and higher).

- High forces applied externally to the manipulator:

Some applications or not correctly programmed paths apply external forces to the manipulator, which might reduce its lifetime. Example of external force: gripper under constraint when gripping a part or load sharing between multiple robots.

- Number of collisions:

Collisions, especially at high speed and/or with high loads reduce the lifetime of the gearboxes. Avoid collisions and set collision detection sensitivity to the appropriate level.



### Note

See the application manual for the controller software, section *Collision detection*, listed in [References on page 7](#).

- Number of emergency stops:

Emergency stops, especially at high speed and/or high loads reduce the lifetime of the gearboxes. Whenever permitted by risk assessment, set the robot stopping functions to stop category 1.

*Continues on next page*



### Note

See the product manual for the robot controller, listed in [References on page 7](#).

---

### Design limitations

See the section *Expected component life* in *Product manual - IRB 6710*.

---

### Maintenance

The maintenance and use of the robot will affect the performance and lifetime. For example:

- Preventive maintenance will optimize the lifetime of the robot. The recommended maintenance activities and intervals are described in *Product manual - IRB 6710*.
- Observance of lubricant types and maintenance periods recommended by ABB.
- Possible pollution of the lubricant by an external cause, for example, water in the oil caused by high humidity.
- Extreme usage, for example high duty factor or environmental factors, will affect the maintenance schedule, for example, shorter intervals for oil change.

Contact your local ABB office to get technical support from ABB.

---

### Individual lifetime variability

The lifetime varies with individual robots. For example, a cycle with a lower duty factor may fail earlier than one with a higher duty factor. But a cycle with a higher duty factor is more likely to fail earlier than a cycle with lower duty factor.

---

### Extreme usage

Examples of extreme usage in regard to movement: a stress index range that shows up as red (51) in the RobotStudio add-in *Mechanical Analysis*, press tending application, very severe palletizing applications, major use of axis 1, 2, or 3 movement.

The controller can issue a duty factor warning on the FlexPendant, if applicable. See the chapter *Troubleshooting* in *Product manual - IRB 6710*.

Extreme usage normally requires usage of cooling fans.

Extreme usage requires specific maintenance, for example, shorter interval for oil change. See *Maintenance schedule* in *Product manual - IRB 6710*.

*Continues on next page*

# 1 Description of IRB 6710

## 1.3 Impacting robot lifetime

Continued

### Summary

The diagram illustrates the relationship between robot run time and failure possibility.

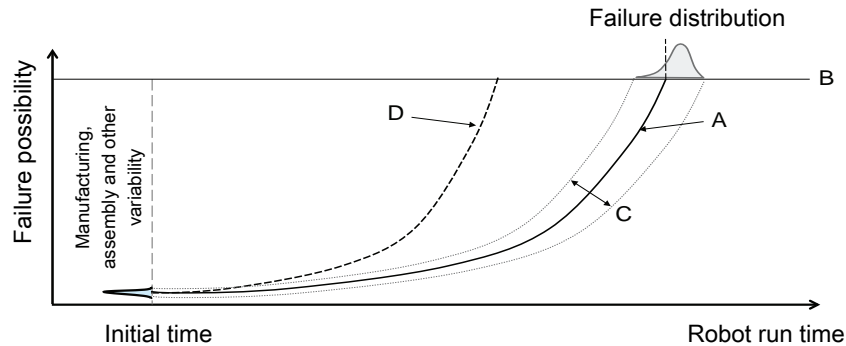

xx2500001942

A	Design lifetime
B	Failure threshold
C	Individual variability
D	Negatively affected lifetime

The curve (A) represents the design lifetime, showing how failure probability increases over time following a normal distribution pattern. The failure threshold (B) indicates the point at which component failure becomes likely.

Individual variability between robots is shown by the dotted lines (C), representing the natural variation in component life due to manufacturing, assembly, and other factors. This variability means that while most robots will follow the design lifetime curve, some individual units may experience earlier or later failures within the normal distribution.

As highlighted with the curve (D) in the diagram, robot lifetime can be negatively affected by not following best practices in the key areas discussed in this chapter:

- [Robot type selection on page 16](#)
- [Duty factor on page 16](#)
- [Environmental conditions on page 17](#)
- [Application and usage on page 17](#)
- [Maintenance on page 19](#)

By adhering to the recommendations outlined in each of these sections, users can maximize their robot's operational lifetime and ensure performance stays within the design lifetime curve, avoiding premature failure and unnecessary downtime.

Continues on next page

### Available tools

There are several tools available throughout the lifecycle of an ABB robot, from support with selecting the most suitable manipulator and optimizing its lifetime, to operation, maintenance, and repair:

ABB toolbox	Type	Product lifecycle		
		Sales, pre-study	Installation, commissioning	Operation, maintenance, repair
Product specification	Document	x	x	
Product manual	Document		x	x
Mechanical Analysis add-in	Add-in in RobotStudio	x	x	x
Service Information System (SIS) / Condition Based Maintenance (CBM)	RobotWare functionality / Customer service analysis		x	x
Connected Services	Hardware and Software		x	x
Automatic Path Planning	RobotStudio functionality and online software	x	x	(x)
Signal Analyzer / TuneMaster	RobotStudio functionality / Software	x	x	x
ABB support	Customer support	x	x	x

# 1 Description of IRB 6710

## 1.4 Applicable standards

### 1.4 Applicable standards

#### General

This product is designed according to the global product standard ISO 10218-1:2025, *Robots for industrial environments - Safety requirements - Part 1 Robots*, In case of deviation from ISO 10218-1:2025, these are listed in the declaration of incorporation. The declaration of incorporation is part of the delivery.

#### Robot standards

Standard	Description
ISO 9283	Manipulating industrial robots – Performance criteria and related test methods
ISO 9787	Robots and robotic devices – Coordinate systems and motion nomenclatures
ISO 9946	Manipulating industrial robots – Presentation of characteristics

#### Other standards used in design

Standard	Description
ISO 9283	Manipulating industrial robots - Performance criteria and related test methods
ISO 9787	Robots and robotic devices -- Coordinate systems and motion nomenclatures
ISO 9946	Manipulating industrial robots - Presentation of characteristics
IEC 61000-6-2	Electromagnetic compatibility (EMC) – Part 6-2: Generic standards – Immunity standard for industrial environments
IEC 61000-6-4	Electromagnetic compatibility (EMC) – Part 6-4: Generic standards – Emission standard for industrial environments
IEC 61326-3-1	Immunity requirements for safety-related systems and for equipment intended to perform safety-related functions (functional safety) – General industrial applications

#### Region specific standards

Standard	Description
UL 1740 (option) CSA Z434 (option)	Standards For Safety - Robots and Robotic Equipment Industrial robots and robot Systems - General safety requirements Valid for USA and Canada.

### 1.5 Maintenance and troubleshooting

---

#### General

The robot requires only minimum maintenance during operation. It has been designed to make it as easy to service as possible:

- Maintenance-free AC motors are used.
- Oil is used for the gearboxes.
- The cabling is routed for longevity, and in the unlikely event of a failure, its modular design makes it easy to change.

---

#### Maintenance

The maintenance intervals depend on the use of the robot. The required maintenance activities also depend on the selected options. For detailed information on maintenance procedures, see the maintenance section in *Product manual - IRB 6710*.

---

#### Troubleshooting

The robot has built-in communication that shows information on the FlexPendant. These messages facilitates troubleshooting and are an integral part of the control system. Troubleshooting procedures are describes in the product manual for the manipulator and the controller respectively.

**This page is intentionally left blank**

## 2 Technical data for IRB 6710

### 2.1 Technical data

#### 2.1.1 Technical data

##### Weight, robot

The table shows the weight of the robot.

Robot model	Nominal weight
IRB 6710-210/2.65	1,140 kg
IRB 6710-200/2.95	1,150 kg
IRB 6710-175/2.65 LID	1,200 kg
IRB 6710-175/2.95 LID	1,210 kg



##### Note

The weight does not include additional options, tools and other equipment fitted on the robot.

The weight includes the weight of the DressPack for LID variants.

##### Mounting positions

The table shows valid mounting positions and the installation (mounting) angle for the manipulator.

Mounting position	Installation angle
Floor mounted	0° <sup>i</sup>

<sup>i</sup> A tilt of up to 5° does not affect the payload or reach, but it can have a negative impact on performance and lifetime. The actual value must be set in the system parameters.



##### Note

The actual mounting angle must always be configured in the system parameters, otherwise the performance and lifetime is affected. See the product manual for details.

On robots running RobotWare 8, it is also possible to configure the mounting position on the FlexPendant, see the integrator's guide for the controller.

*Continues on next page*

## 2 Technical data for IRB 6710

### 2.1.1 Technical data

Continued

#### Loads on foundation, robot

The illustration shows the directions of the robots stress forces.

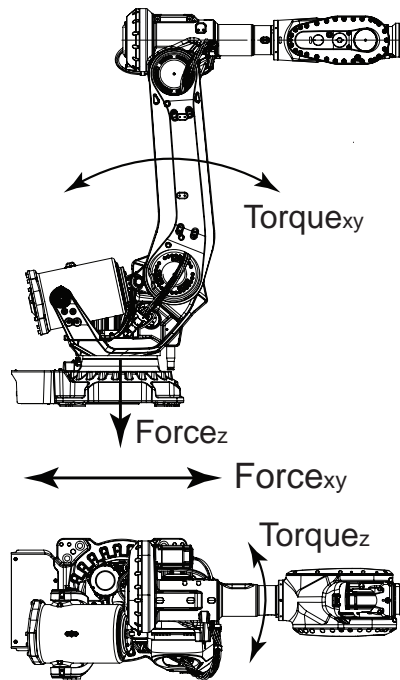

xx2200001958

The table shows the various forces and torques working on the robot during different kinds of operation.



#### Note

These forces and torques are extreme values that are rarely encountered during operation. The values also never reach their maximum at the same time!



#### WARNING

The robot installation is restricted to the mounting options given in following load table(s).

#### Floor mounted

Force	Endurance load (in operation)	Maximum load (emergency stop)
Force xy	±7.4 kN	±19.4 kN
Force z	14.1 ±4.2 kN	14.1 ±16.3 kN
Torque xy	±19.5 kNm	±35.8 kNm
Torque z	±5 kNm	±12.3 kNm

Continues on next page

**Requirements, foundation**

The table shows the requirements for the foundation where the weight of the installed robot is included:

Requirement	Value	Note
Flatness of foundation surface	0.3 mm	Flat foundations give better repeatability of the resolver calibration compared to original settings on delivery from ABB. The value for levelness aims at the circumstance of the anchoring points in the robot base. In order to compensate for an uneven surface, the robot can be recalibrated during installation. If resolver/encoder calibration is changed this will influence the absolute accuracy
Minimum resonance frequency	22 Hz  <b>Note</b> It may affect the manipulator lifetime to have a lower resonance frequency than recommended.	The value is recommended for optimal performance. Due to foundation stiffness, consider robot mass including equipment. <sup>i</sup> For information about compensating for foundation flexibility, see the description of <i>Motion Process Mode</i> in the manual that describes the controller software option, see <a href="#">References on page 7</a> .

<sup>i</sup> The minimum resonance frequency given should be interpreted as the frequency of the robot mass/inertia, robot assumed stiff, when a foundation translational/torsional elasticity is added, i.e., the stiffness of the pedestal where the robot is mounted. The minimum resonance frequency should not be interpreted as the resonance frequency of the building, floor etc. For example, if the equivalent mass of the floor is very high, it will not affect robot movement, even if the frequency is well below the stated frequency. The robot should be mounted as rigid as possibly to the floor.  
Disturbances from other machinery will affect the robot and the tool accuracy. The robot has resonance frequencies in the region 10 – 20 Hz and disturbances in this region will be amplified, although somewhat damped by the servo control. This might be a problem, depending on the requirements from the applications. If this is a problem, the robot needs to be isolated from the environment.

**Storage conditions, robot**

The table shows the allowed storage conditions for the robot:

Parameter	Value
Minimum ambient temperature	-25 °C
Maximum ambient temperature	55 °C
Maximum ambient temperature (less than 24 hrs)	70 °C
Maximum ambient humidity	95%

**Operating conditions, robot**

The table shows the allowed operating conditions for the robot:

Parameter	Value
Minimum ambient temperature	5 °C <sup>i</sup>
Maximum ambient temperature	50 °C
Maximum ambient humidity	95% at constant temperature

<sup>i</sup> At low environmental temperature < 10°C is, as with any other machine, a warm-up phase recommended to be run with the robot. Otherwise there is a risk that the robot stops or run with lower performance due to temperature dependent oil and grease viscosity.

*Continues on next page*

## 2 Technical data for IRB 6710

---

### 2.1.1 Technical data

*Continued*

---

#### Protection classes, robot

The table shows the available protection types of the robot, with the corresponding protection class.

Protection type	Protection class <sup>i</sup>
Manipulator, protection type Standard	IP67
Manipulator, protection type Foundry Plus 2	IP67

<sup>i</sup> According to IEC 60529.

---

#### Environmental information

The product complies with IEC 63000. *Technical documentation for the assessment of electrical and electronic products with respect to the restriction of hazardous substances.*

## 2.1.2 Airborne noise level

### Airborne noise level

Description	Note	Value
Airborne noise level	The sound pressure level outside the working space.	74 dB (A) Leq

The noise emission is measured at four points on a radius 1 m outside the robots maximum working range and at 1.5 m above the robot base level, while the manipulator follows a defined cycle according to VDMA 24608, at max performance and payload.

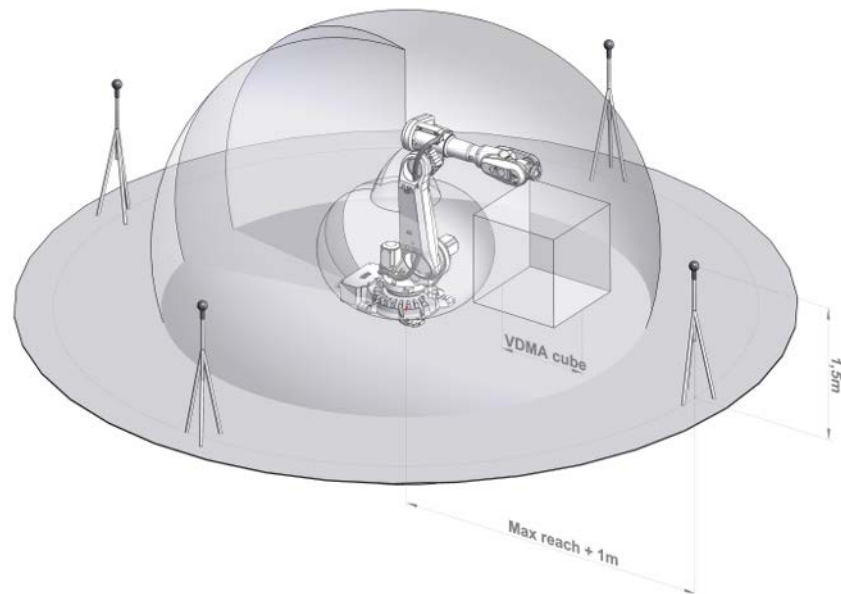

xx2100002505



#### Note

The noise emission from a robot, in an actual application, depends on the programmed path, payload, cycle time, mounting position, environment, etc.

## 2 Technical data for IRB 6710

### 2.1.3 Power consumption

### 2.1.3 Power consumption

#### Power consumption at max load

Variant <sup>i</sup>	ISO cube	Robot in calibration position	
	Power consumption at maximum velocity (kW)	Power consumption at brakes engaged (kW)	Power consumption at brakes disengaged (kW)
IRB 6710-210/2.65	2.5	0.17	0.70
IRB 6710-200/2.95	2.4	0.16	0.80

<sup>i</sup> LID manipulator variants are considered to have the same data as specified variants with the same reach.

#### ISO cube

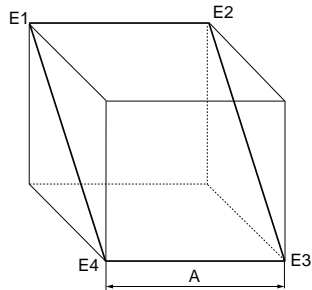

xx100000101

Pos	Description
A	1,000 mm



#### Note

If measuring the power consumption at the installation site, the returned power to the grid needs to be taken in to account.

2.1.4 Working range

Illustration, working range IRB 6710-210/2.65

This illustration shows the unrestricted working range of the robot.

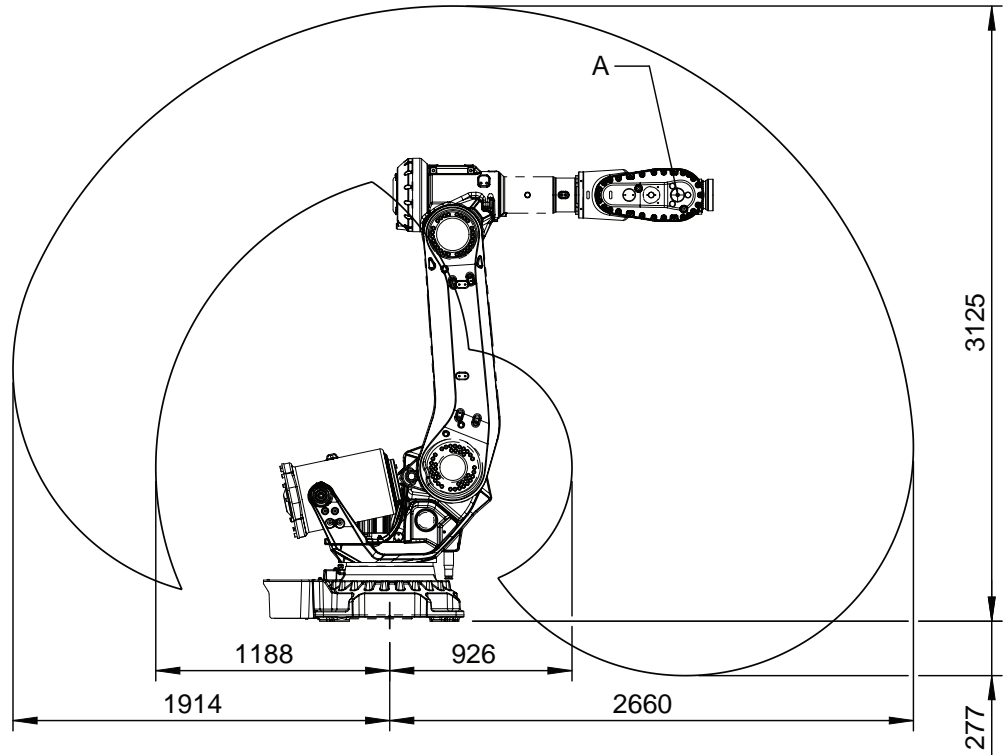

xx2200001961

A	Path intersect with axis-5 center
---	-----------------------------------

Continues on next page

## 2 Technical data for IRB 6710

### 2.1.4 Working range

Continued

#### Illustration, working range IRB 6710-200/2.95

This illustration shows the unrestricted working range of the robot.

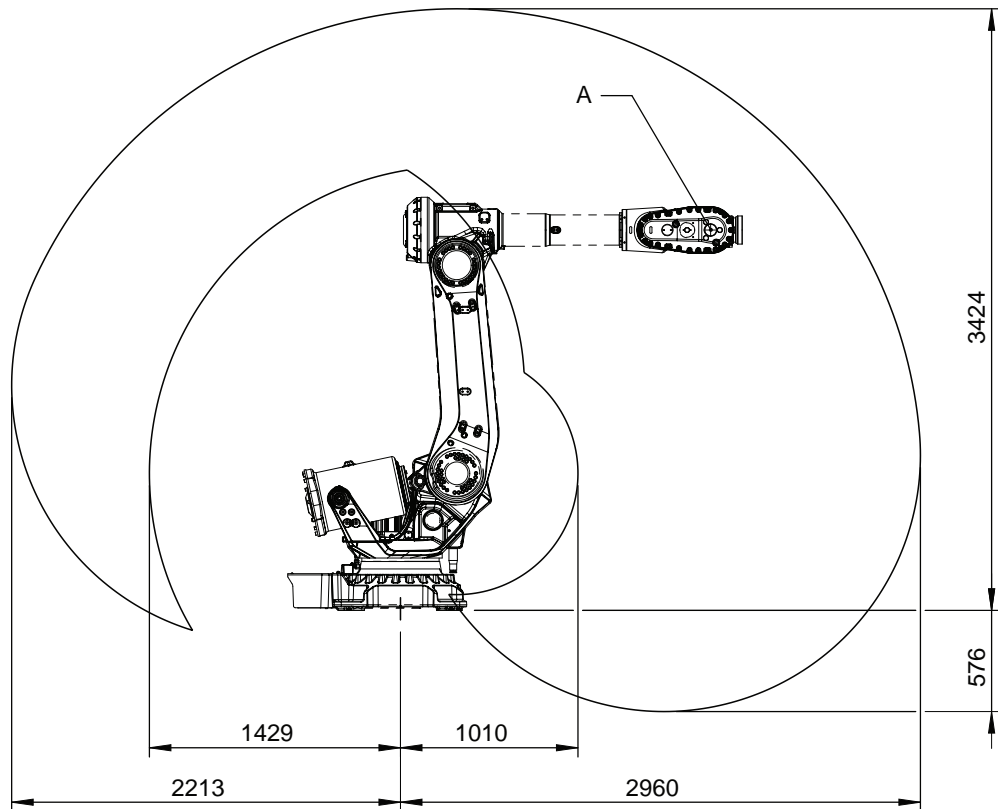

xx2200001962

A	Path intersect with axis-5 center
---	-----------------------------------

Continues on next page

**Illustration, working range IRB 6710-175/2.65 LID**

This illustration shows the unrestricted working range of the robot.

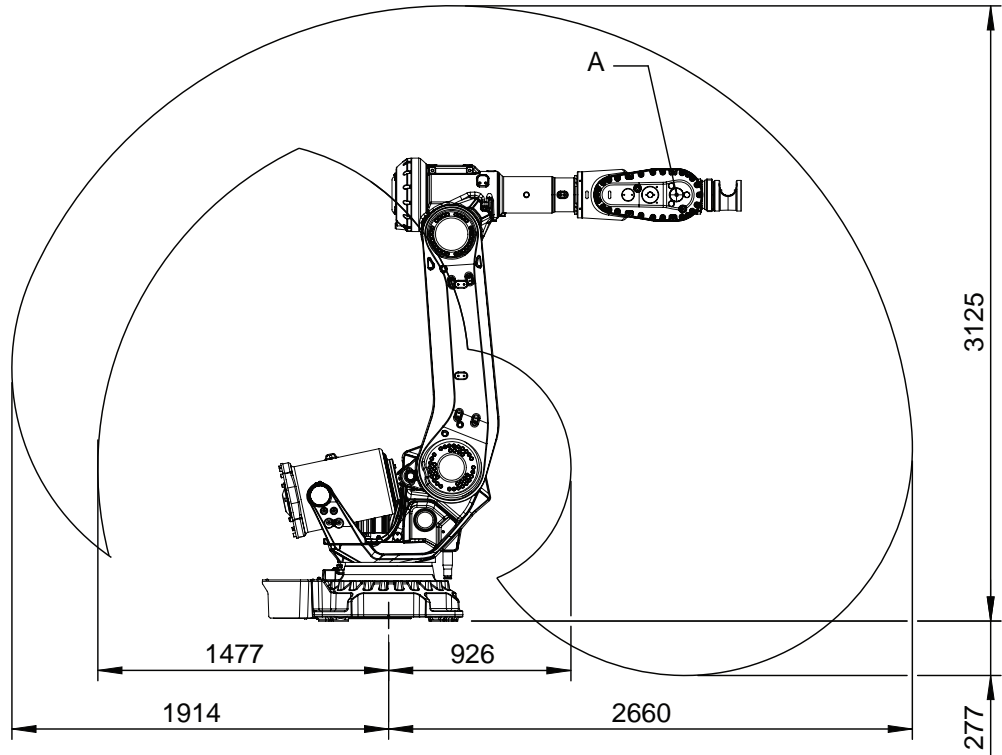

xx2200001963

A	Path intersect with axis-5 center
---	-----------------------------------

*Continues on next page*

## 2 Technical data for IRB 6710

### 2.1.4 Working range

*Continued*

#### Illustration, working range IRB 6710-175/2.95 LID

This illustration shows the unrestricted working range of the robot.

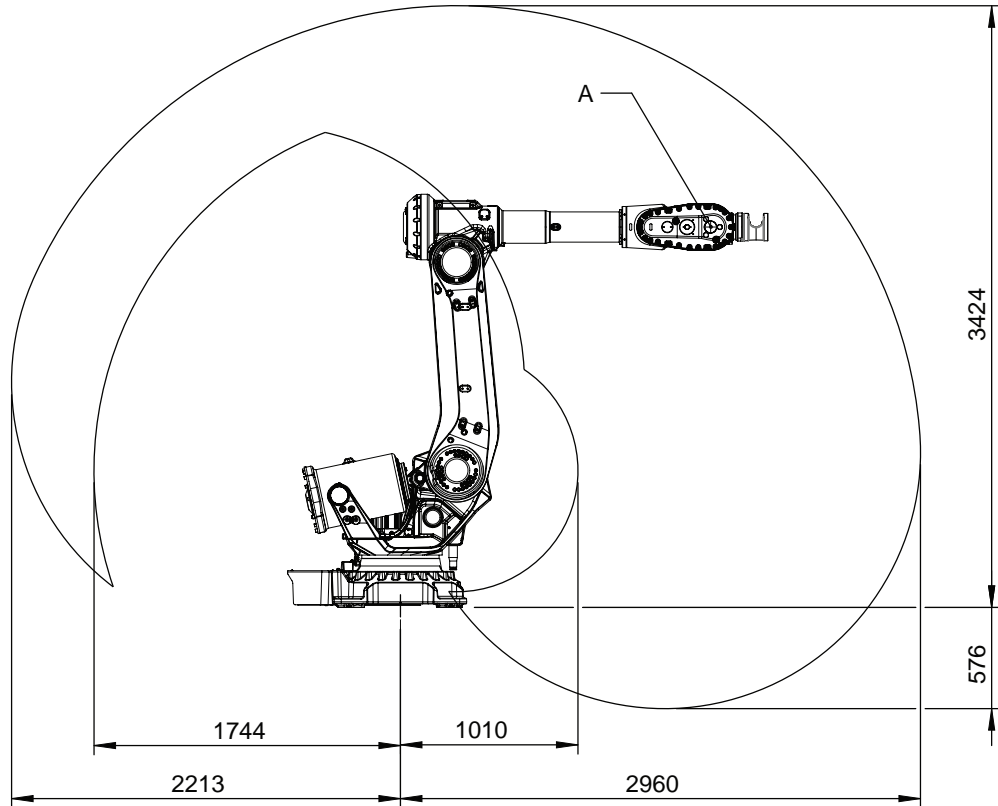

A	Path intersect with axis-5 center
---	-----------------------------------

*Continues on next page*

Top view of working range

IRB 6710-210/2.65, IRB 6710-175/2.65 LID

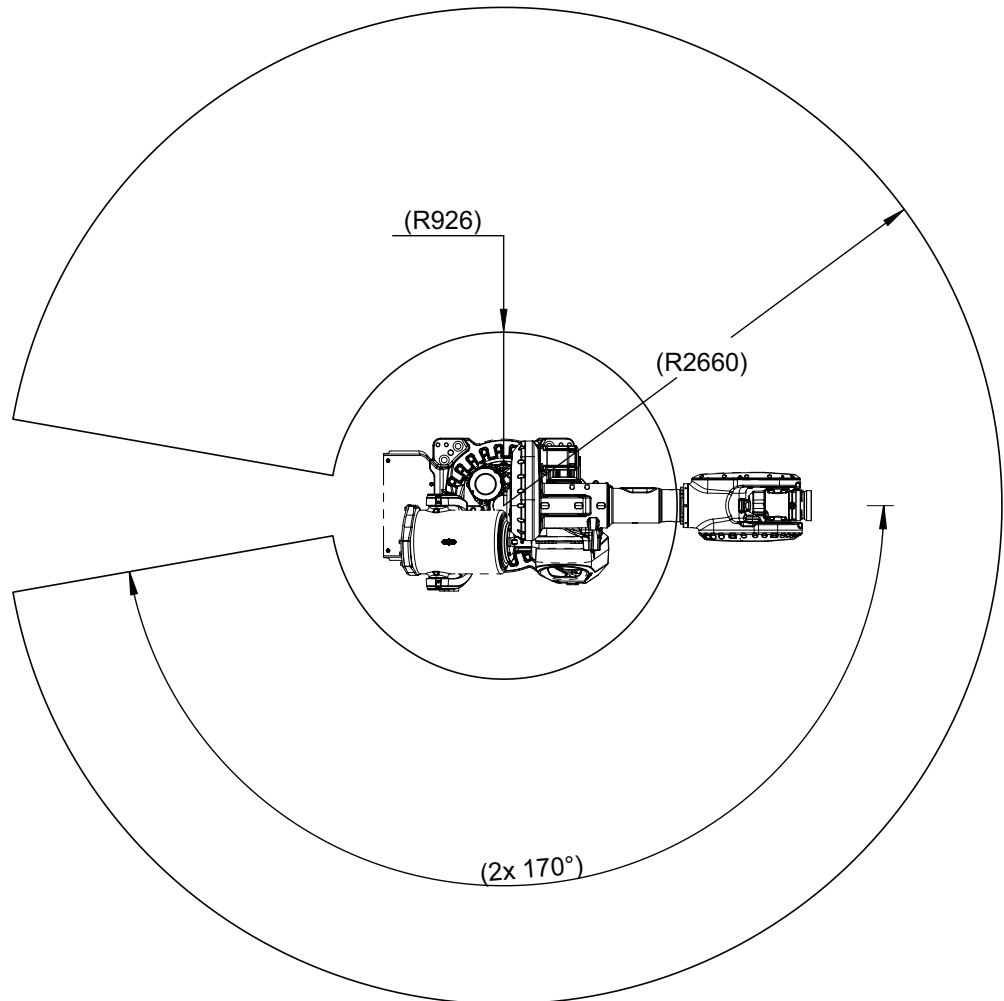

xx2200001985

Continues on next page

## 2 Technical data for IRB 6710

### 2.1.4 Working range

Continued

IRB 6710-200/2.95, IRB 6710-175/2.95 LID

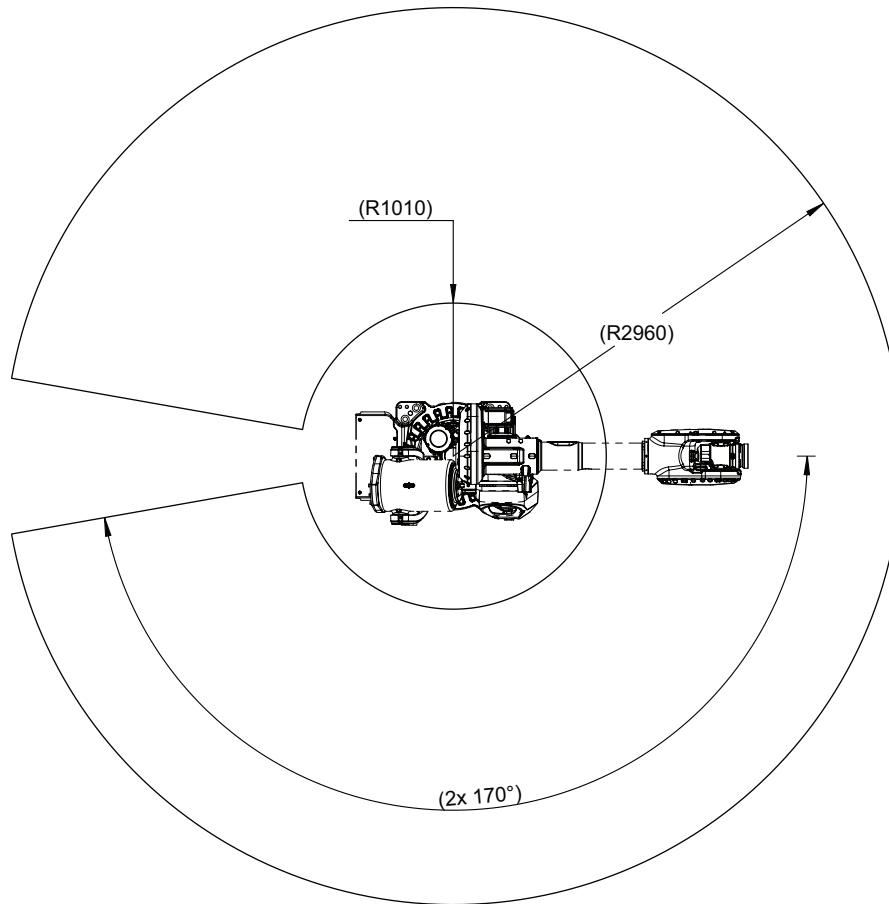

xx2200001986

### Working range

Axis	Working range	Note
Axis 1	$\pm 170^\circ$	
	$\pm 220^\circ$ <sup>i</sup>	The default working range for axis 1 can be extended as an option.
Axis 2	$-65^\circ/+85^\circ$	
Axis 3	$-180^\circ$ <sup>ii</sup> / $+70^\circ$	IRB 6710-210/2.65, IRB 6710-200/2.95
	$-160^\circ/+70^\circ$	IRB 6710-175/2.65 LID, IRB 6710-175/2.95 LID
Axis 4	$\pm 300^\circ$	
Axis 5	$\pm 130^\circ$	IRB 6710-210/2.65, IRB 6710-200/2.95
	$\pm 120^\circ$ <sup>iii</sup>	IRB 6710-175/2.65 LID, IRB 6710-175/2.95 LID
Axis 6	$\pm 360^\circ$	IRB 6710-210/2.65, IRB 6710-200/2.95
	$\pm 220^\circ$ <sup>iii</sup>	IRB 6710-175/2.65 LID, IRB 6710-175/2.95 LID

<sup>i</sup> Option Extended Working Range Axis 1 (3324-1)

Not valid with DressPack SW.

<sup>ii</sup>  $-160^\circ$  if lower arm DressPack is installed

<sup>iii</sup> Maximum combined movements reduced.

Continues on next page

See [Working range limitations, axis 5 and axis 6 for IRB 6710-175/2.65 LID, IRB 6710-175/2.95 LID \(option axis 3-6 \[3326-x\]\) on page 38](#).

### Working range limitation

The working range of axis 1 can be reduced by altering the parameter values. Installation of additional mechanical stops or safe supervision is recommended. See [Working range alterations on page 59](#).

## 2 Technical data for IRB 6710

### 2.1.5 Robot motion

### 2.1.5 Robot motion

#### Limitations of robot movements for LeanID

Robot variants with LeanID have restricted working range implemented in RobotWare. See [Working range on page 36](#).

#### Working range limitations, axis 5 and axis 6 for IRB 6710-175/2.65 LID, IRB 6710-175/2.95 LID (option axis 3-6 [3326-x])

The allowed working area for axis 6 related to axis 5 position is shown in the figure below.

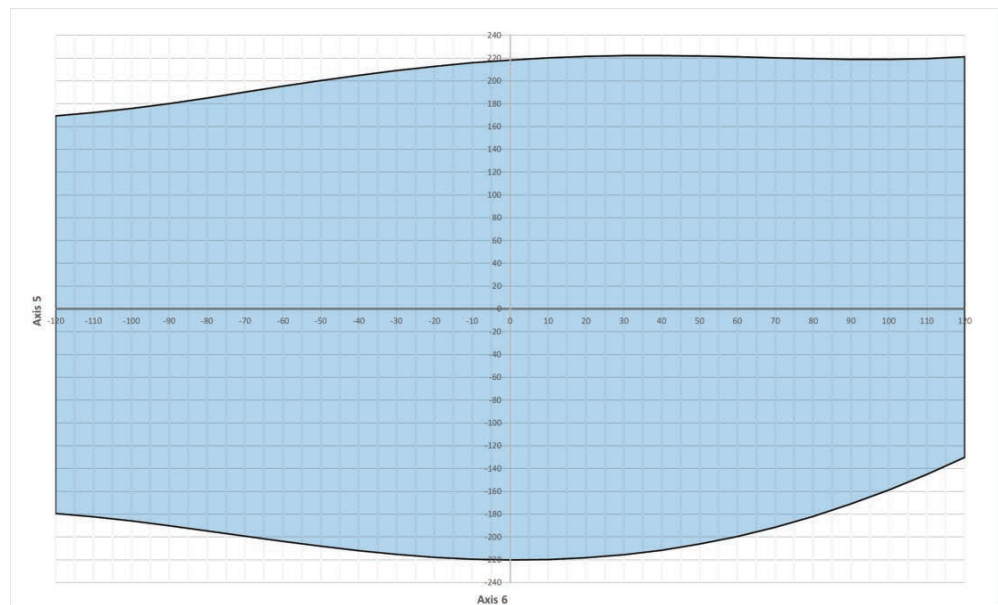

xx2300000253



#### Note

The working range for LeanID variants is controlled and protected by software.

2.2 Fitting equipment on the robot (robot dimensions)

Robot dimensions

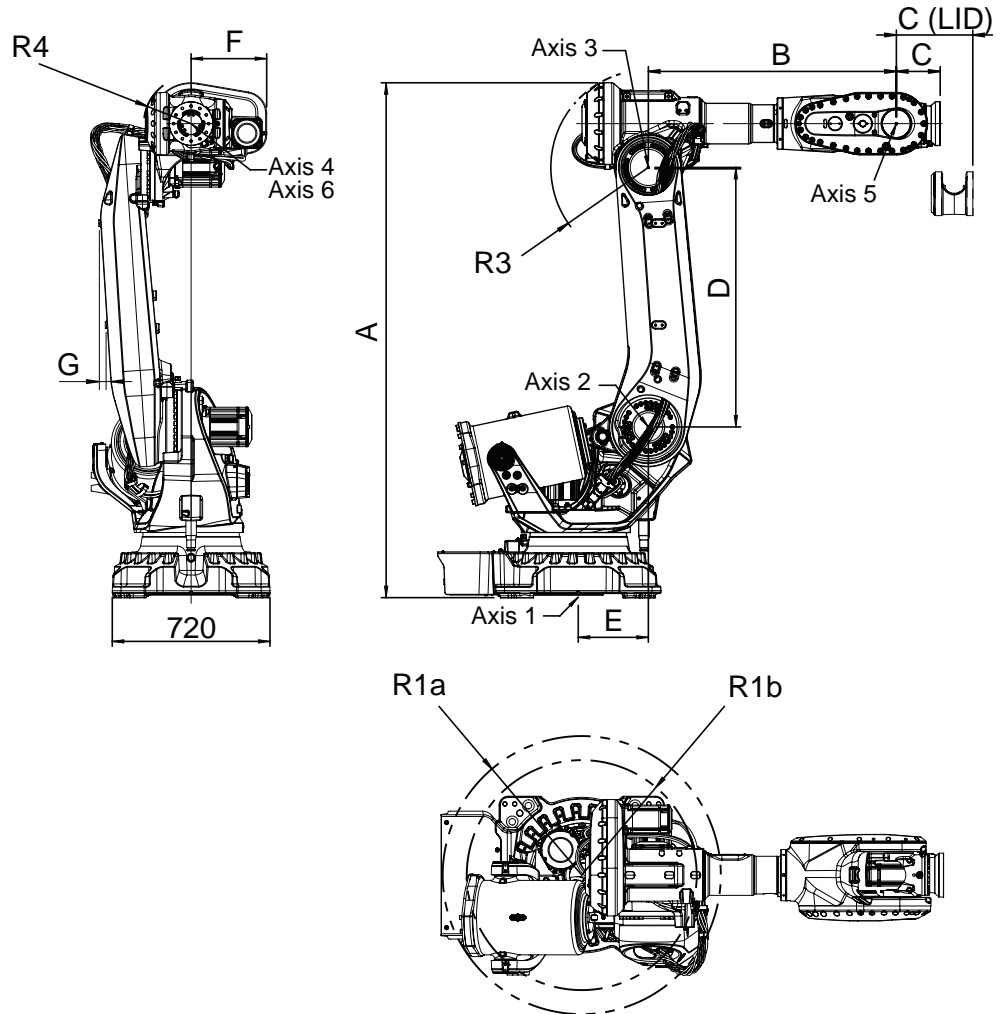

xx2200002031

R1a	Smallest circumscribed radius around axis 1 (back side)
R1b	Smallest circumscribed radius around axis 1 (front side)
R3	Smallest circumscribed radius around axis 3
R4	Smallest circumscribed radius around axis 4

Measurements

The measurements are given in mm.

Variant	A	B	C	D	E	F	G	R1a	R1b	R3	R4
IRB 6710-210/2.65	2,351.5	1,142.5	180	1,185	320	345	30	634	525	446	200
IRB 6710-200/2.95	2,351.5	1,445.5	180	1,185	320	345	30	634	525	446	200
IRB 6710-175/2.65 LID	2,351.5	1,142.5	346	1,185	320	345	30	634	525	446	200

Continues on next page

## 2 Technical data for IRB 6710

### 2.2 Fitting equipment on the robot (robot dimensions)

Continued

Variant	A	B	C	D	E	F	G	R1a	R1b	R3	R4
IRB 6710-175/2.95 LID	2,351.5	1,445.5	346	1,185	320	345	30	634	525	446	200

#### Extra load on the robot

Extra loads can be mounted on robot. Definitions of dimensions and masses are shown in the following figures. The robot is supplied with holes for fitting extra equipment.

Maximum allowed arm load depends on center of gravity of arm load and robot payload.

#### Frame

The table and figure shows allowed extra load on the frame.

	Description
Permitted extra load on frame	$J_H = 100 \text{ kgm}^2$
Recommended position (see the following figure)	$J_H = J_{H0} + M4 \times R^2$ where: <ul style="list-style-type: none"> <li>• <math>J_{H0}</math> is the moment of inertia of the equipment</li> <li>• <math>R</math> is the radius (m) from the center of axis 1</li> <li>• <math>M4</math> is the total mass (kg) of the equipment including bracket and harness (<math>\leq 250 \text{ kg}</math>)</li> </ul>

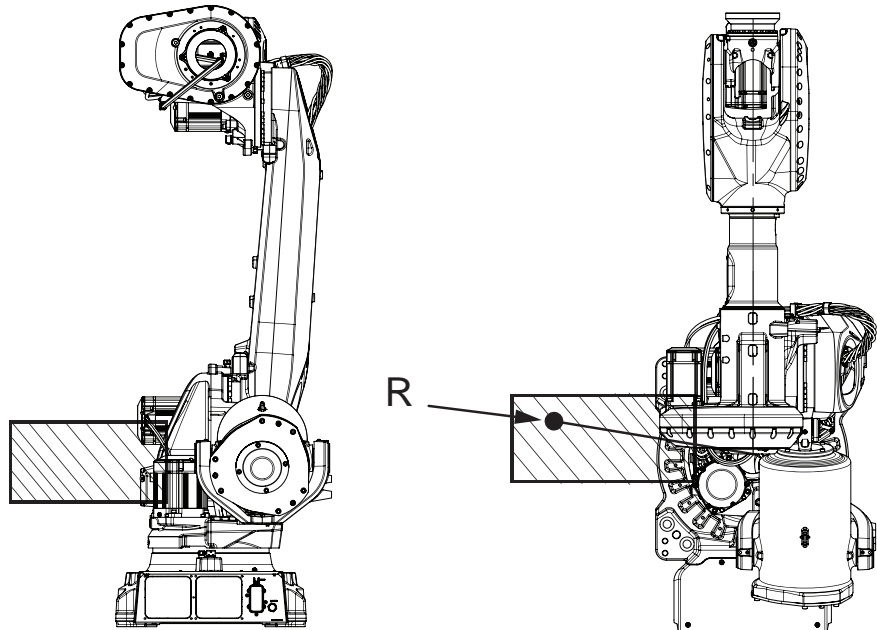

xx2300000346

#### Upper arm

The figure shows the position for a nominal extra load of 50 kg on the upper arm housing on a standard robot. For more precise calculations of allowed extra load

Continues on next page

up to maximum 200 kg in combination with the reduced payload, use RobotStudio add-in RobotLoad or contact ABB.

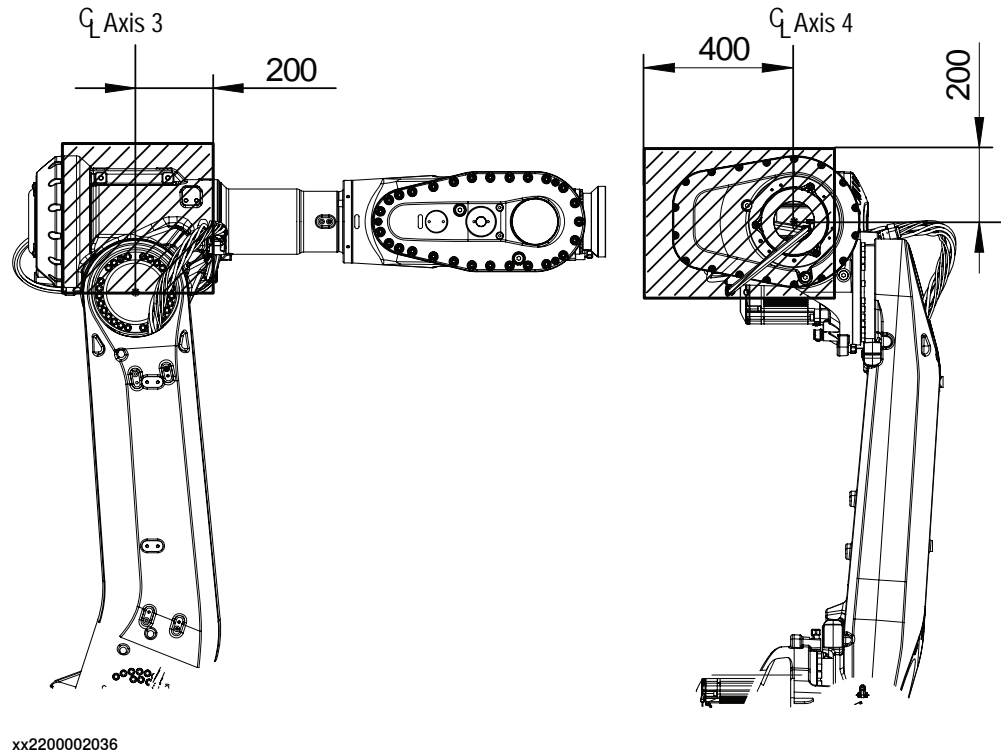

#### Attachment holes for fitting extra equipment

The robot is supplied with holes for fitting extra equipment.

*Continues on next page*

## 2 Technical data for IRB 6710

### 2.2 Fitting equipment on the robot (robot dimensions)

Continued

#### Upper arm

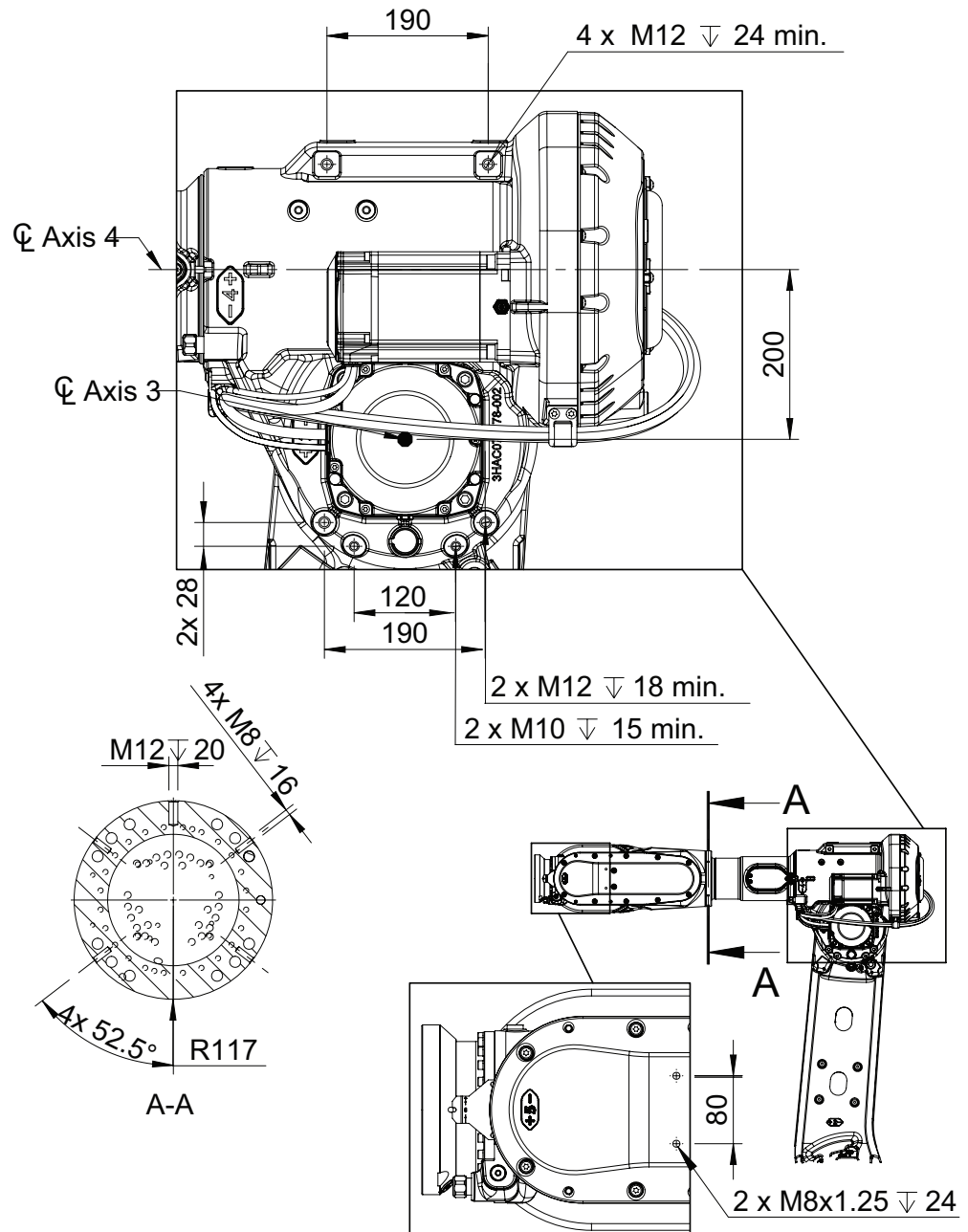

xx2200002039

Continues on next page

## 2 Technical data for IRB 6710

### 2.2 Fitting equipment on the robot (robot dimensions)

Continued

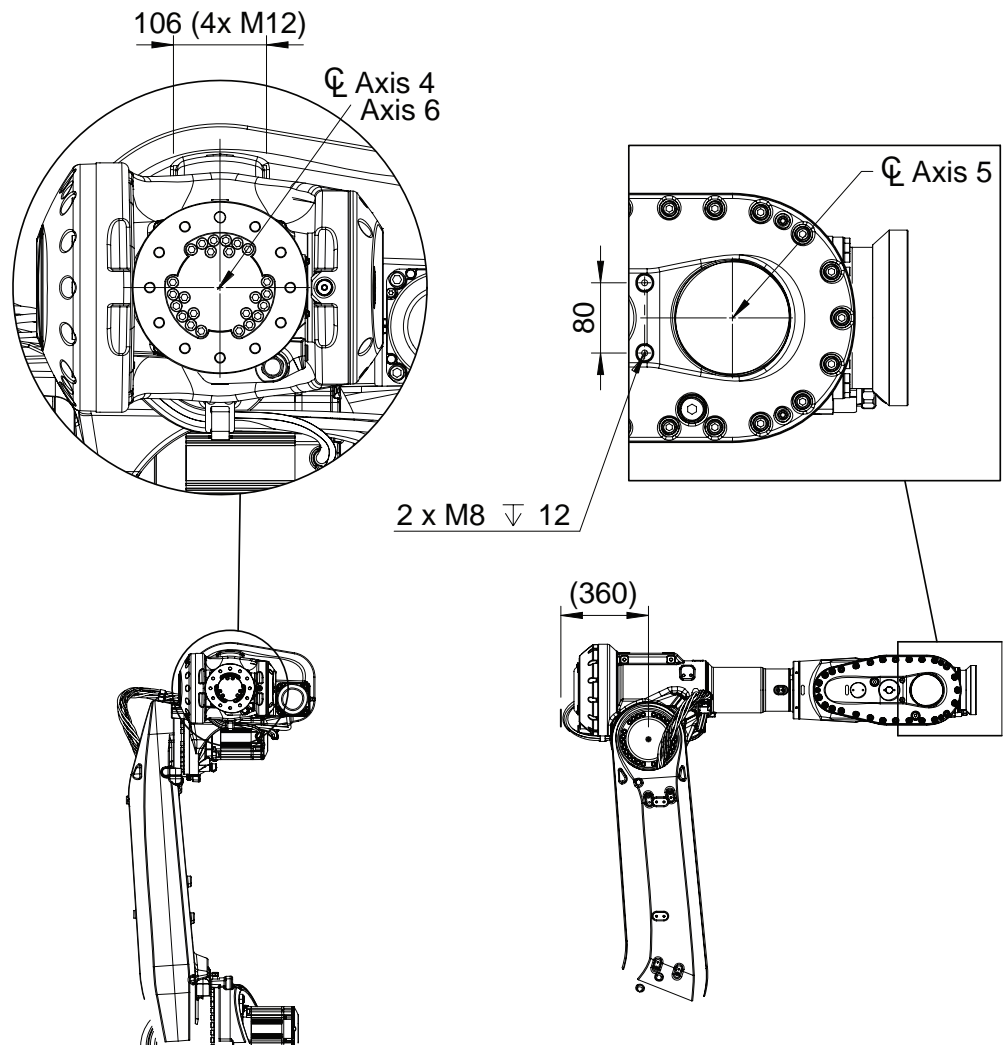

xx2200002040

Continues on next page

## 2 Technical data for IRB 6710

### 2.2 Fitting equipment on the robot (robot dimensions)

Continued

Lower arm

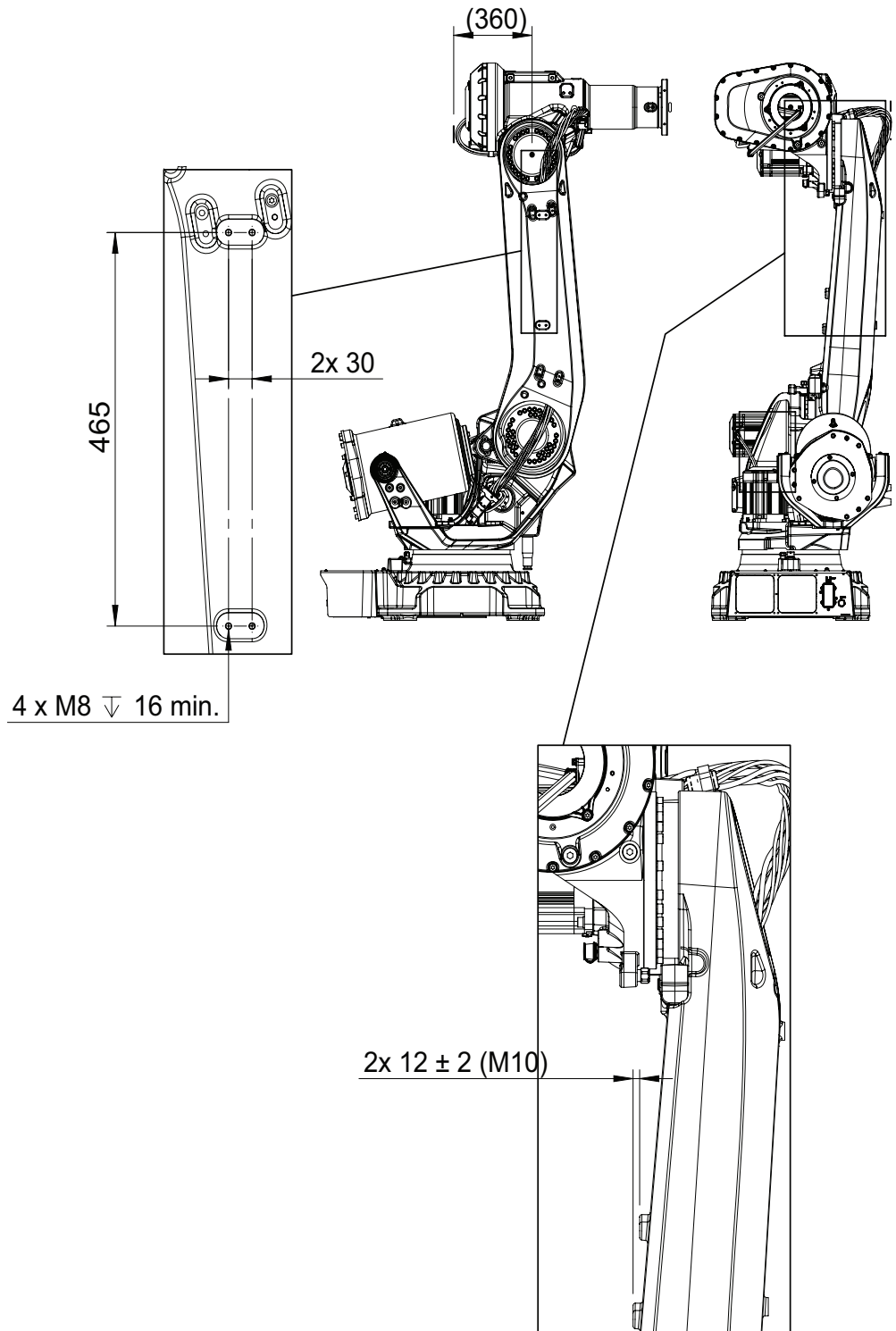

xx2200002055

Continues on next page

## 2 Technical data for IRB 6710

### 2.2 Fitting equipment on the robot (robot dimensions)

*Continued*

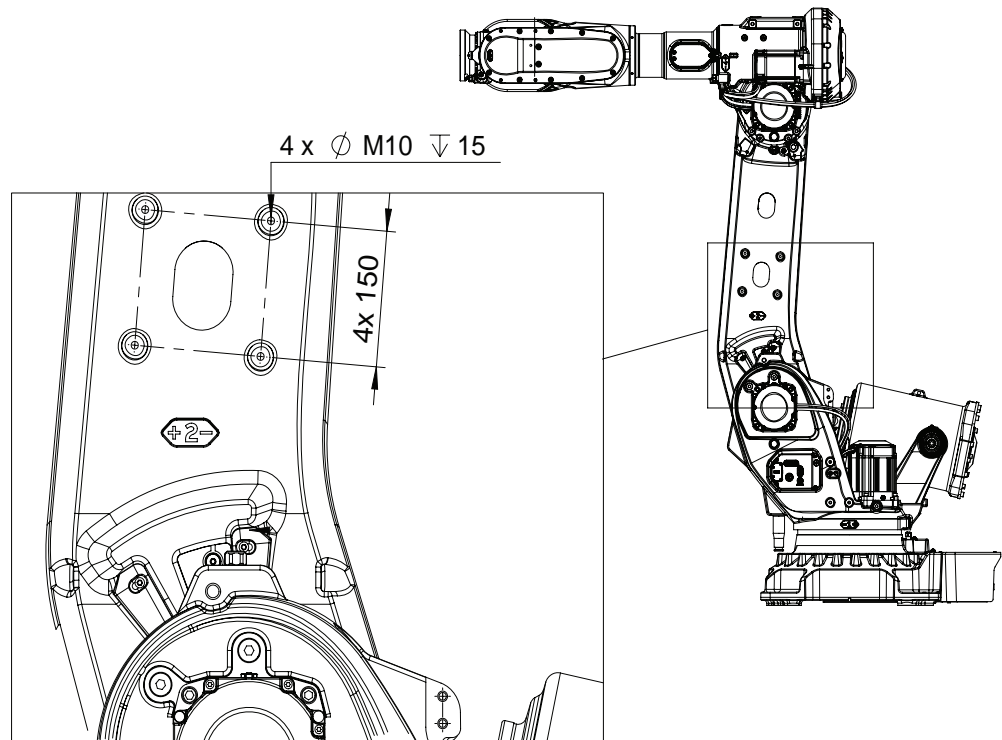

xx2200002056

*Continues on next page*

## 2 Technical data for IRB 6710

### 2.2 Fitting equipment on the robot (robot dimensions)

Continued

#### Frame

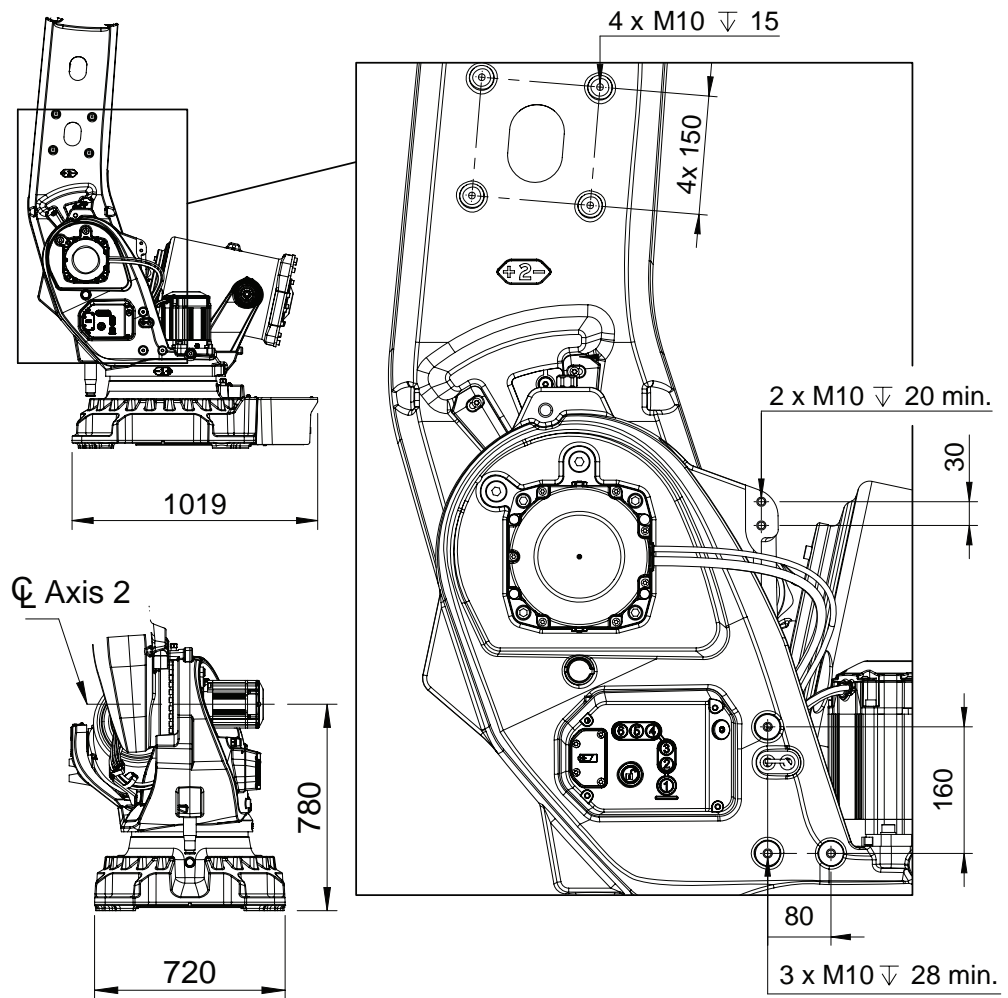

xx2200002057

Continues on next page

Tool flange dimensions

Robot variant	Tool flange dimension
IRB 6710-210/2.65 IRB 6710-200/2.95	<p> <math>\varnothing 10 \text{ H7} \nabla 12</math>  <math>\varnothing 0.04 \text{ A}</math>  <math>11 \times \text{M10} \nabla 18</math>  <math>\varnothing 0.2 \text{ A B}</math>  <math>12 \times 30^\circ</math>  <math>\varnothing 80 \text{ H7}</math>  <math>\varnothing 125</math>  <math>1 \times 45^\circ</math>  <math>160 \text{ h8}</math>  <math>8 \text{ min. } (\varnothing 80 \text{ H7})</math>  <math>1 \times 45^\circ</math>  <math>\text{A}</math>  <math>\text{B}</math>  <small>xx2200002060</small> </p>
IRB 6710-175/2.65 LID IRB 6710-175/2.95 LID	<p> <math>\varnothing 10 \text{ H7} \nabla 15</math>  <math>\varnothing 0.07 \text{ A}</math>  <math>11 \times \text{M10} \nabla 16</math>  <math>\varnothing 0.2 \text{ A B}</math>  <math>12 \times 30^\circ</math>  <math>\varnothing 125</math>  <math>\varnothing 80 \text{ H7}</math>  <math>\varnothing 0.02 \text{ A}</math>  <math>8 \text{ min. } (\varnothing 80 \text{ H7})</math>  <math>1 \times 45^\circ</math>  <math>160 \text{ h8}</math>  <math>1 \times 45^\circ</math>  <math>\text{A}</math>  <math>\text{B}</math>  <small>xx2300000940</small> </p>

Fastener quality

When fitting tools on the tool flange, only use screws with quality 12.9. For other

Continues on next page

## 2 Technical data for IRB 6710

---

### 2.2 Fitting equipment on the robot (robot dimensions)

*Continued*

equipment use suitable screws and tightening torque for your application.

## 2.3 Mechanical data for installation

### Detailed installation instructions

All detailed installation instructions are found in *Product manual - IRB 6710*.

### Attachment screws

The table below specifies the type of securing screws and washers to be used for securing the robot to the base plate/steel structure foundation.

Suitable screws	M24 x 100
Quantity	8 pcs
Quality	8.8
Suitable washer	4 mm flat washer
Guide pins	Locating pin: 3HAC051645-001 (2 pcs) Locating pins are required if mounting the manipulator to a track motion or to a base plate. Locating pins are also required for robots with option Absolute Accuracy. For more information, see <a href="#">Base plate, locating pins on page 55</a> .
Tightening torque	550 Nm (screws lubricated with Molykote 1000) 600-725 Nm, typical 650 Nm (screws none or lightly lubricated)
Screw tightening yield point utilization factor (v) (according to VDI2230)	90% (v=0.9)
Level surface requirements	0.3 mm <sup>i</sup>

<sup>i</sup> See [Requirements, foundation on page 27](#).

*Continues on next page*

## 2 Technical data for IRB 6710

### 2.3 Mechanical data for installation

Continued

#### Hole configuration, base

This illustration shows the hole configuration used when securing the robot.

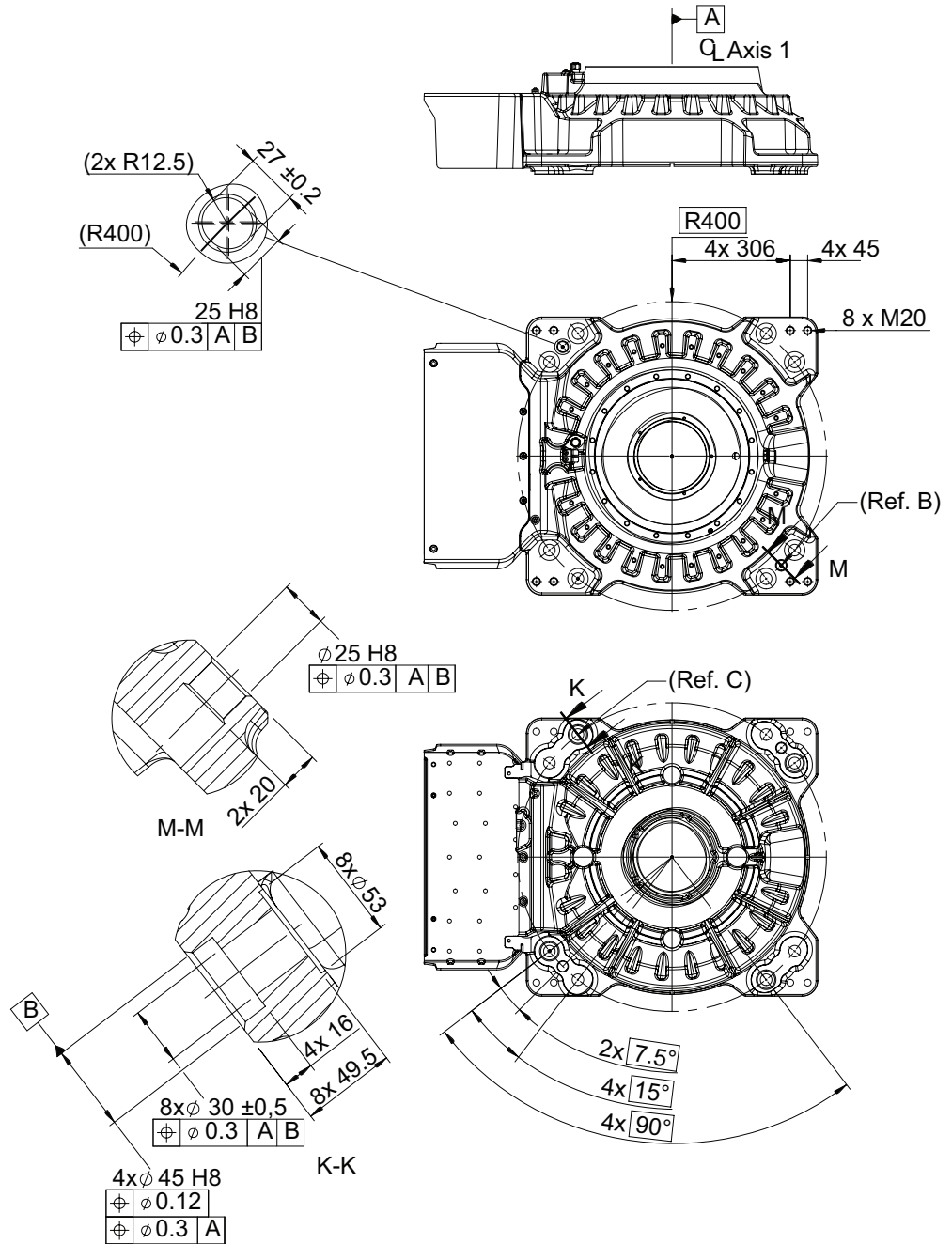

xx2200001840

## 2.4 Installing a base plate

### Advantages of using a base plate

Instead of installing the robot directly on the floor, a base plate can be manufactured and used as an adapter between the floor and the robot base. This list specifies some of the advantages of using a base plate:

- to ensure a plain surface with a high precision of the robot base hole configuration
- to simplify adjustment of levelness by machined surfaces or by using shims
- to distribute the press force from the robot to a larger foot print
- to compensate poor floor quality that might not be suitable for fastening the robot base directly onto. The base plate has a greater number of fastening points to the foundation and makes a larger footprint, which reduces the load on each fastening point.
- to reduce surface pressure on the foundation contact points, which minimizes the risk of wearing down an uneven surface and thereby causing changes in the robot fastening tightening torque
- to be able to prepare the installation site before robot delivery
- to increase the precision between the positions of an installed robot and other equipment



#### Note

Do not use a base plate for installation of an inverted robot.

*Continues on next page*

## 2 Technical data for IRB 6710

### 2.4 Installing a base plate

Continued

#### Base plate drawing

The following figure shows the dimensions for a base plate (dimensions in mm).

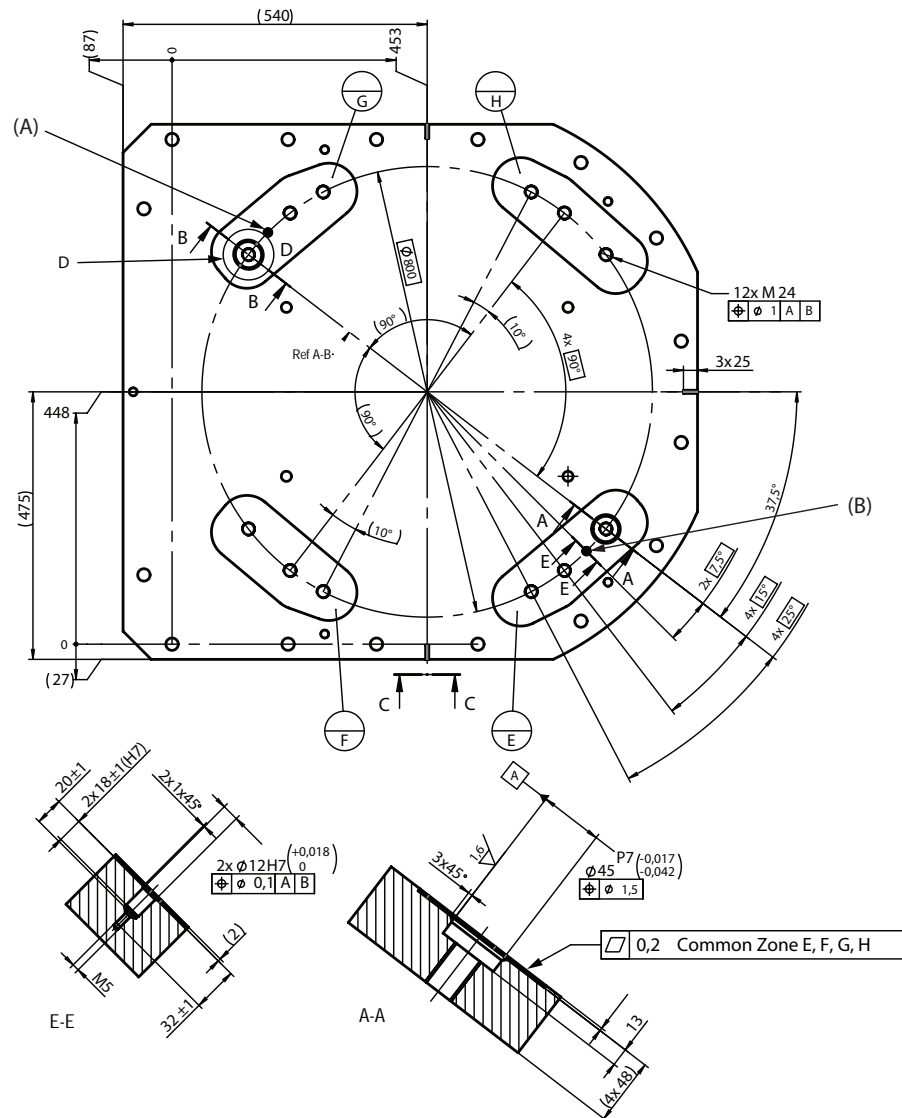

xx1500000246

Pos	Description
A, B	Hole for locating pins, see <a href="#">Base plate, locating pins on page 55</a>
E, F, G, H	Common tolerance zone (accuracy all over the base plate from one contact surface to the other)

Continues on next page

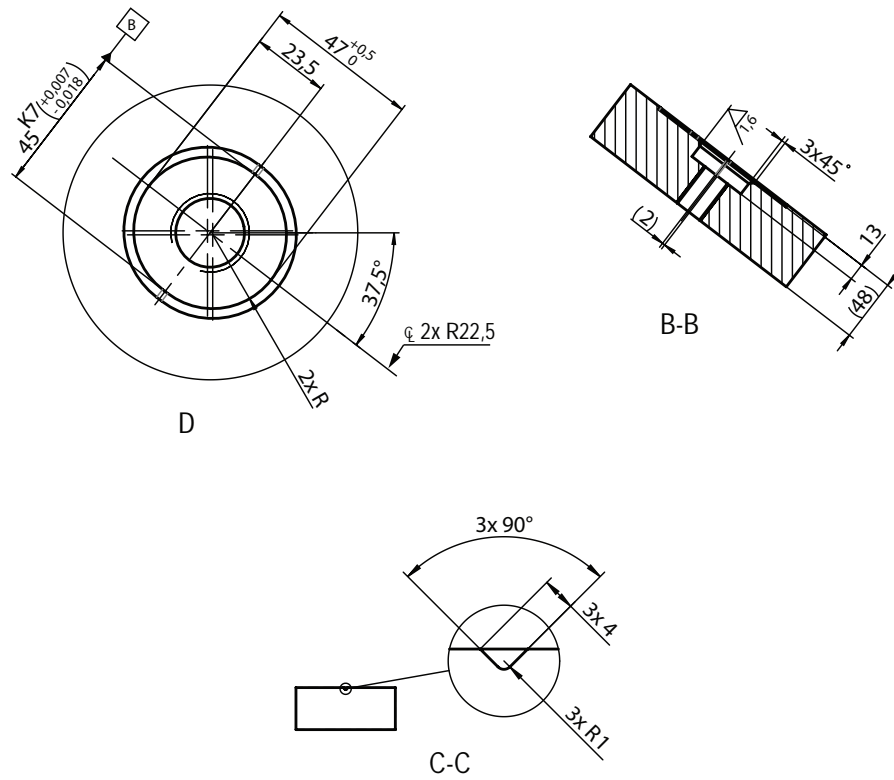

xx1500000247

## 2 Technical data for IRB 6710

### 2.4 Installing a base plate

Continued

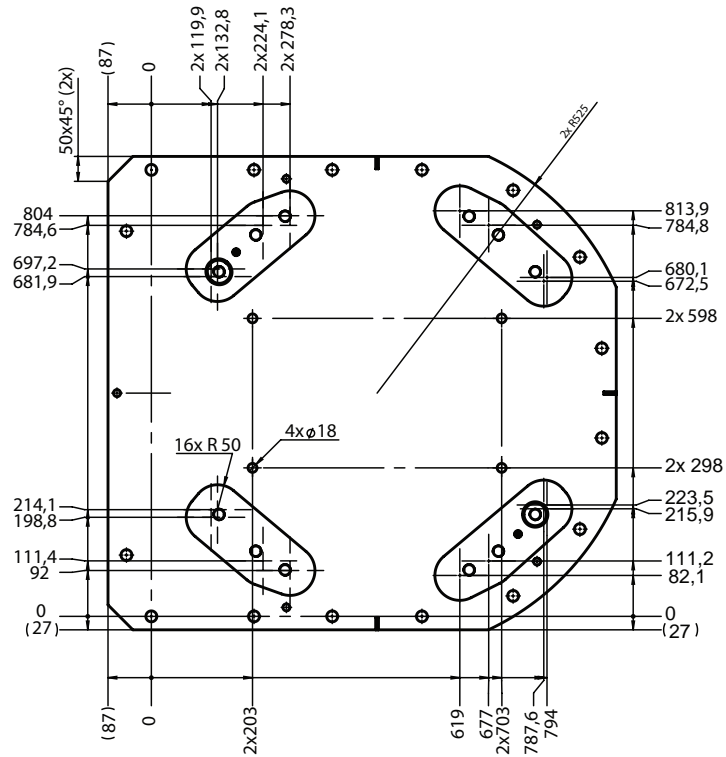
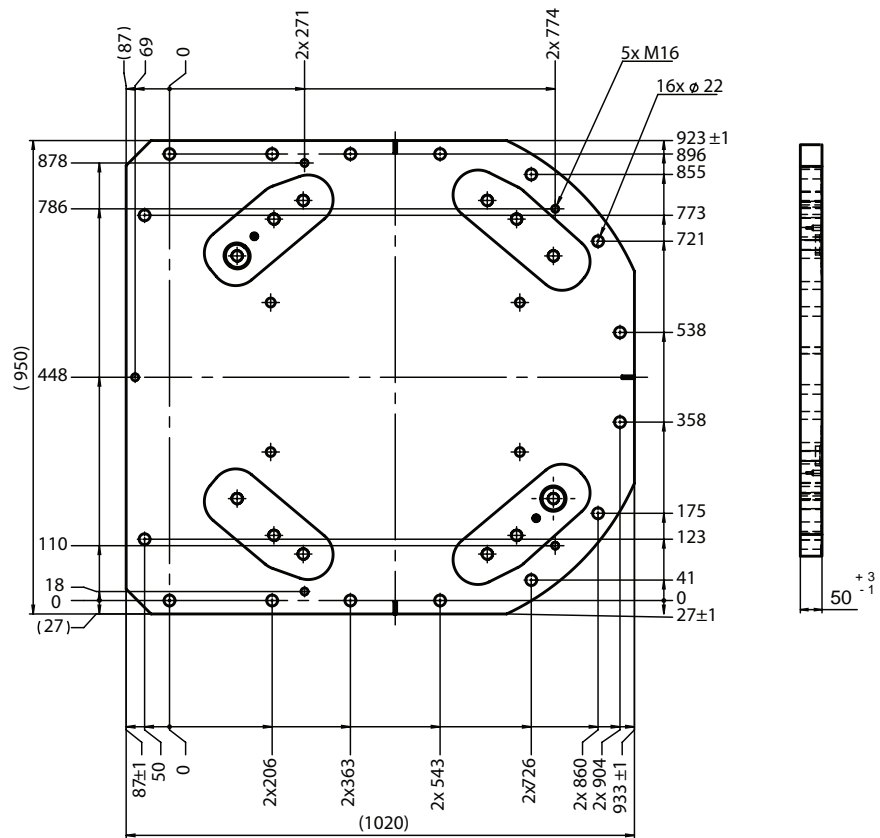

xx1500000249

Continues on next page

**Base plate, orienting grooves and leveling bolts**

The illustration below shows the orienting grooves and attachment holes for leveling bolts in the base plate.

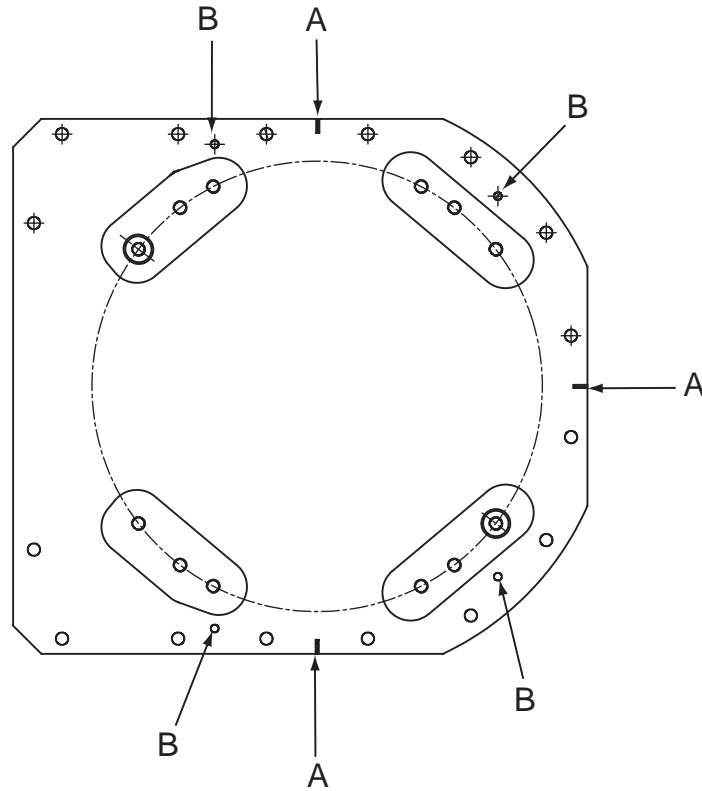

xx150000312

A	Orienting grooves (3 pcs)
B	Levelling bolts, attachment holes (4 pcs)

**Base plate, locating pins**

Locating pins are the recommended positioning components and especially required for robots with option Absolute Accuracy.

*Continues on next page*

## 2 Technical data for IRB 6710

### 2.4 Installing a base plate

*Continued*

#### Assembly of locating pins

The figure below shows the locating pins installed in the base plate.

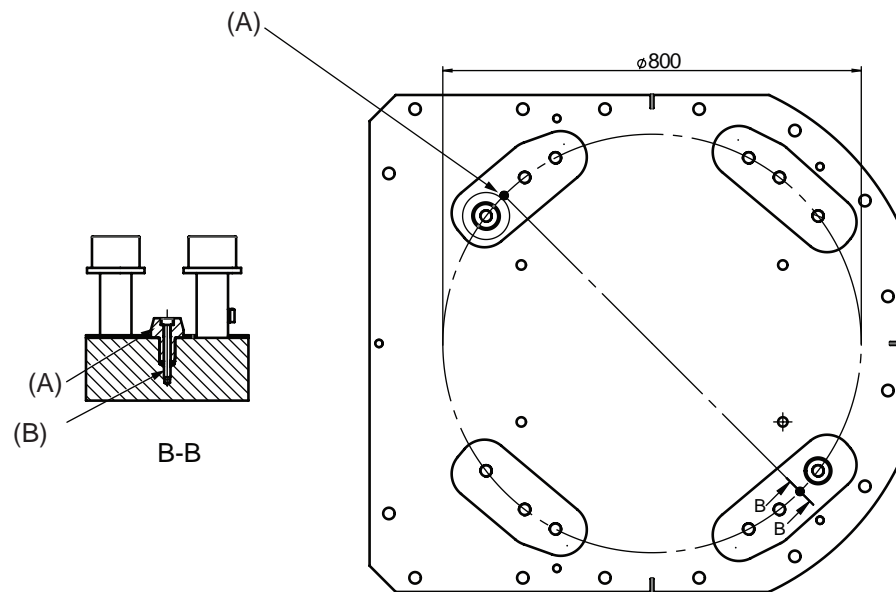

xx1500000250

Pos	Description
A	Locating pin: 3HAC051645-001 (2 pcs)
B	M5 x 40. Tightening torque 6 Nm. (x2)

*Continues on next page*

Dimension of locating pins (guide pins)

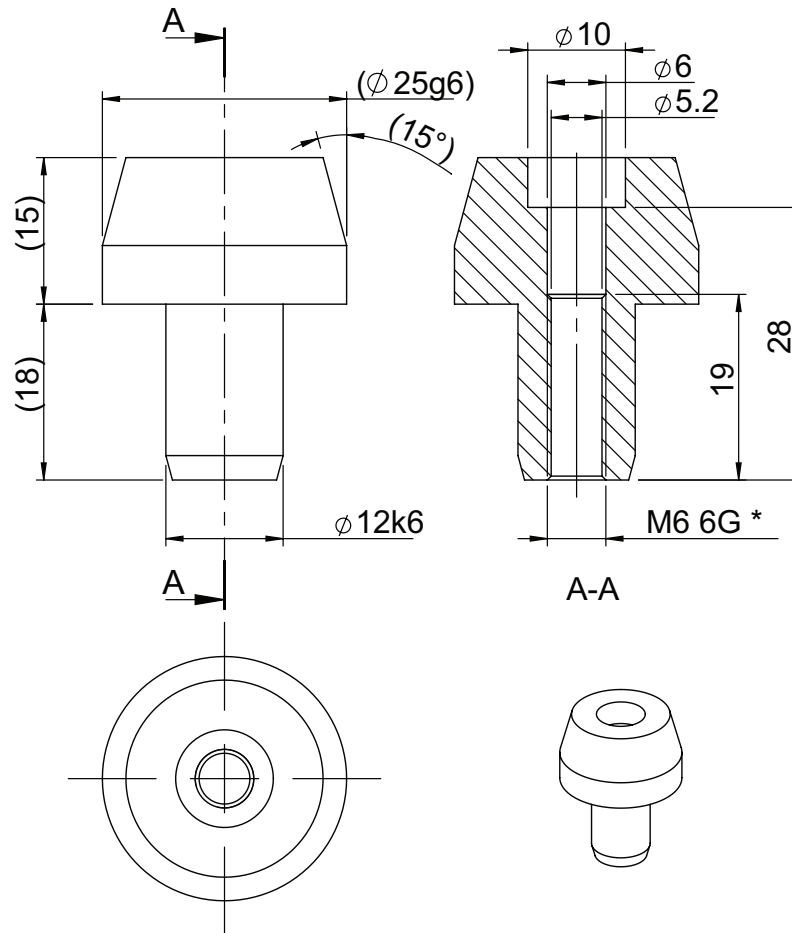

XX1500000248

Pos	Description
-	Cylindrical guide pin (Requires attachment screws, see <a href="#">Assembly of locating pins on page 56.</a> )
*	Threaded M6 hole that can be used for removal of the locating pin, for example with a slide hammer.

Base plate, guide sleeve holes

Guide sleeves are not recommended for robots with option Absolute Accuracy.  
The illustration below shows the guide sleeve holes in the base plate.

Continues on next page

## 2 Technical data for IRB 6710

### 2.4 Installing a base plate

*Continued*

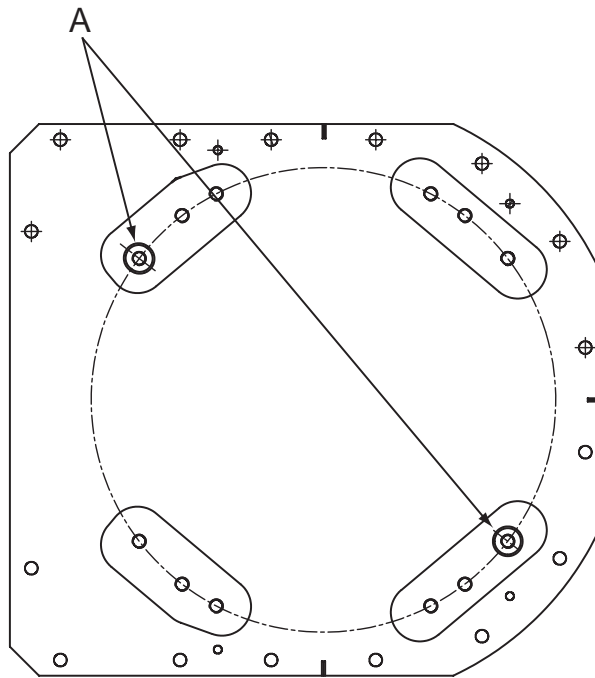

xx0300000045

A	Guide sleeve holes (2 pcs)
---	----------------------------

## 2.5 Working range alterations

### 2.5.1 Adjusting the working range

#### Reasons for adjusting the manipulator working range

The working range of each manipulator axis is configured in the software. If there is a risk that the manipulator may collide with other objects at installation site, its working space should be limited. The manipulator must always be able to move freely within its entire working space.



#### Note

If safe supervision is used, then use the robot stopping distance and time data to determine the requirements on restricted space. See the product specification for the manipulator.

#### Working range configurations

The parameter values for the axes working range can be altered within the allowed working range and according to available options for the robot, either to limit or to extend a default working range. Allowed working ranges and available options for each manipulator axis are specified in [Working range on page 36](#).

#### Mechanical stops on the manipulator

Mechanical stops are and can be installed on the manipulator as limiting devices to ensure that the manipulator axis does not exceed the working range values set in the software parameters.



#### Note

The mechanical stops are only installed as safety precaution to physically stop the robot from exceeding the working range set. A collision with a mechanical stop always requires actions for repair and troubleshooting.

Axis	Fixed mechanical stop <sup>i</sup>	Movable mechanical stop <sup>ii</sup>
Axis 1	yes	yes The working range can be reduced by altering the parameter values. Installation of additional mechanical stops is recommended. The working range can be extended (option 3324-1) by altering the parameter values and removing the movable mechanical stop pin.
Axis 2	yes	no
Axis 3	yes	no
Axis 4	no	no
Axis 5	yes	no

*Continues on next page*

## 2 Technical data for IRB 6710

---

### 2.5.1 Adjusting the working range

*Continued*

Axis	Fixed mechanical stop <sup>i</sup>	Movable mechanical stop <sup>ii</sup>
Axis 6	no	no

<sup>i</sup> Part of the casting or fixed on the casting and can not /should not be removed.

<sup>ii</sup> Can be installed in one or more than one position, to ensure a reduced working range, or be removed to allow extended working range.

2.5.2 Installing movable mechanical stops on axis 1 (option 3323-1)

Reduction of the axis-1 working range

The working range of axis 1 is limited by system parameter configuration. To reduce the working range from default range, first adjust the parameter values and then install additional mechanical stops as a safety measure.

The movable mechanical stops reduce the working range according to the table.

Graduation of limited working range	Reduction of working range
15°	from ±5° and ±125° in both directions

Illustration, reduced working range

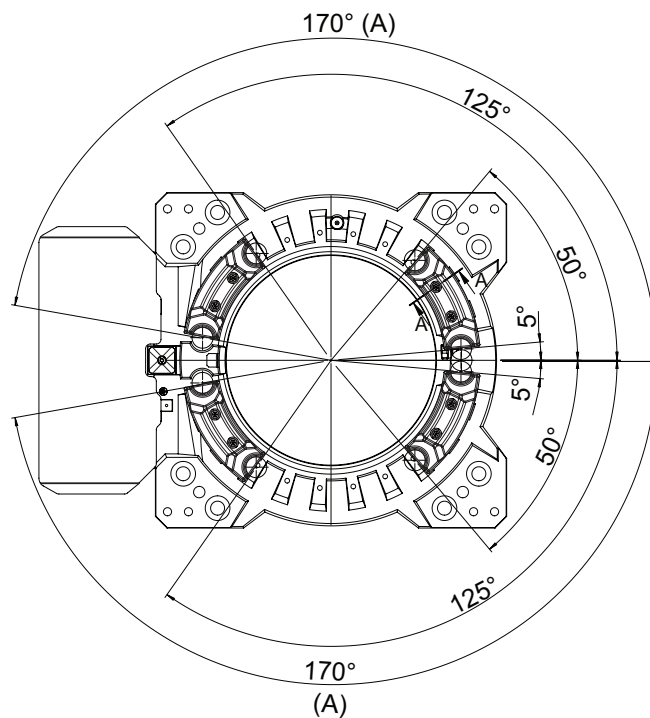

xx210000973

A	Standard working range without limitations
---	--



**WARNING**

If the mechanical stop pin is deformed after a hard collision, it must be replaced! Deformed movable stops and/or additional stops as well as deformed attachment screws must also be replaced after a hard collision.

*Continues on next page*

## 2 Technical data for IRB 6710

### 2.5.2 Installing movable mechanical stops on axis 1 (option 3323-1)

Continued

#### Location of the mechanical stops

The mechanical stops are located as shown in the figure.

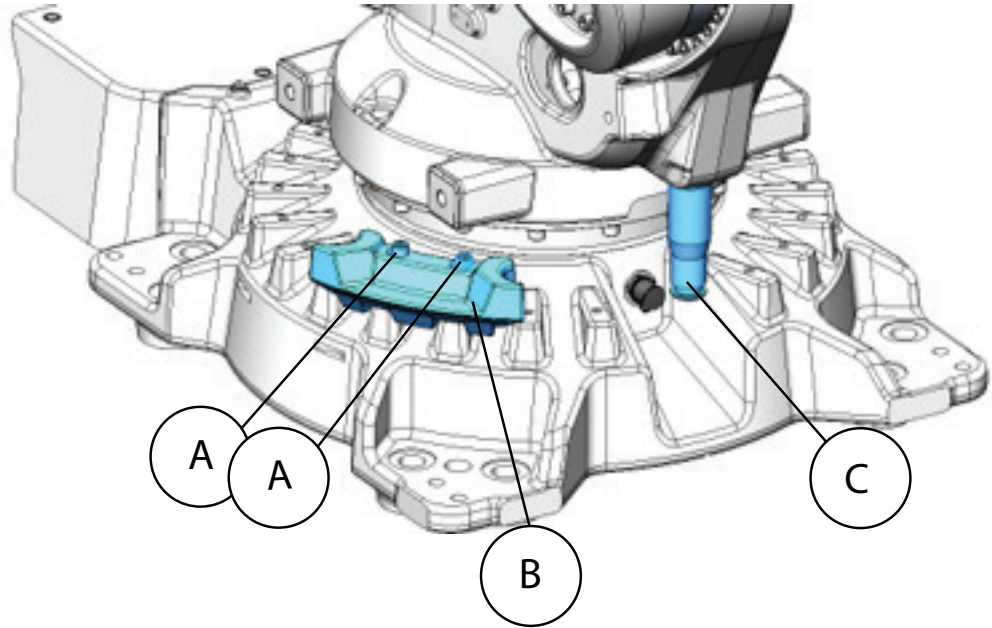

xx2100002647

A <sup>i</sup>	Attachment screws M12x70 quality 12.9 and washers DIN 125 (2 pcs per additional mechanical stop); Tightening torque 60 Nm
B	Movable mechanical stop
C	Mechanical stop pin axis-1

<sup>i</sup> There is a need to drill and make threaded M12 holes in base.  
Use the movable mechanical stop or the dents in the casting as a guide to drill.

#### Installing the movable mechanical stops

See the product manual for installation procedure.

## 2.6 Calibration and references

### 2.6.1 Calibration methods

#### Overview

This section specifies the different types of calibration and the calibration methods that are supplied by ABB.

More information is available in the product manual.

#### Types of calibration

Type of calibration	Description	Calibration method
Standard calibration	The calibrated robot is positioned at calibration position. Standard calibration data is found on the SMB (serial measurement board) or EIB in the robot.	Axis Calibration
Absolute accuracy calibration (optional)	Based on standard calibration, and besides positioning the robot at synchronization position, the Absolute accuracy calibration also compensates for: <ul style="list-style-type: none"> <li>• Mechanical tolerances in the robot structure</li> <li>• Deflection due to load</li> </ul> <p>Absolute accuracy calibration focuses on positioning accuracy in the Cartesian coordinate system for the robot.</p> <p>Absolute accuracy calibration data is found on the serial measurement board (SMB) or other robot memory.</p> <p>A robot calibrated with Absolute accuracy has the option information printed on its name plate (OmniCore).</p> <p>To regain 100% Absolute accuracy performance, the robot must be recalibrated for absolute accuracy after repair or maintenance that affects the mechanical structure.</p>	CalibWare
Optimization	Optimization of TCP reorientation performance. The purpose is to improve reorientation accuracy for continuous processes like welding and gluing. Wrist optimization will update standard calibration data for axes 4 and 5.   <b>Note</b> For advanced users, it is also possible to do the wrist optimization using the RAPID instruction <code>WristOpt</code> , see <i>Technical reference manual - RAPID Instructions, Functions and Data types</i> . This instruction is only available for OmniCore robots.	Wrist Optimization

*Continues on next page*

## 2 Technical data for IRB 6710

---

### 2.6.1 Calibration methods

*Continued*

---

#### Brief description of calibration methods

##### Axis Calibration method

Axis Calibration is a standard calibration method for calibration of IRB 6710. It is the recommended method in order to achieve proper performance.

The following routines are available for the Axis Calibration method:

- Fine calibration
- Update revolution counters
- Reference calibration

The calibration equipment for Axis Calibration is delivered as a toolkit.

The actual instructions of how to perform the calibration procedure and what to do at each step is given on the FlexPendant. You will be guided through the calibration procedure, step by step.

##### Wrist Optimization method

Wrist Optimization is a method for improving reorientation accuracy for continuous processes like welding and gluing and is a complement to the standard calibration method.

The actual instructions of how to perform the wrist optimization procedure is given on the FlexPendant.

##### CalibWare - Absolute Accuracy calibration

The CalibWare tool guides through the calibration process and calculates new compensation parameters. This is further detailed in the *Application manual - CalibWare Field*.

If a service operation is done to a robot with the option Absolute Accuracy, a new absolute accuracy calibration is required in order to establish full performance. For most cases after replacements that do not include taking apart the robot structure, standard calibration is sufficient.

The Absolute Accuracy option varies according to the robot mounting position. This is printed on the robot name plate for each robot. The robot must be in the correct mounting position when it is recalibrated for absolute accuracy.

## 2.6.2 Synchronization marks and synchronization position for axes

### Introduction

This section shows the position of the synchronization marks and the synchronization position for each axis.

### Synchronization marks, IRB 6710, IRB 6720, IRB 6730, IRB 6740

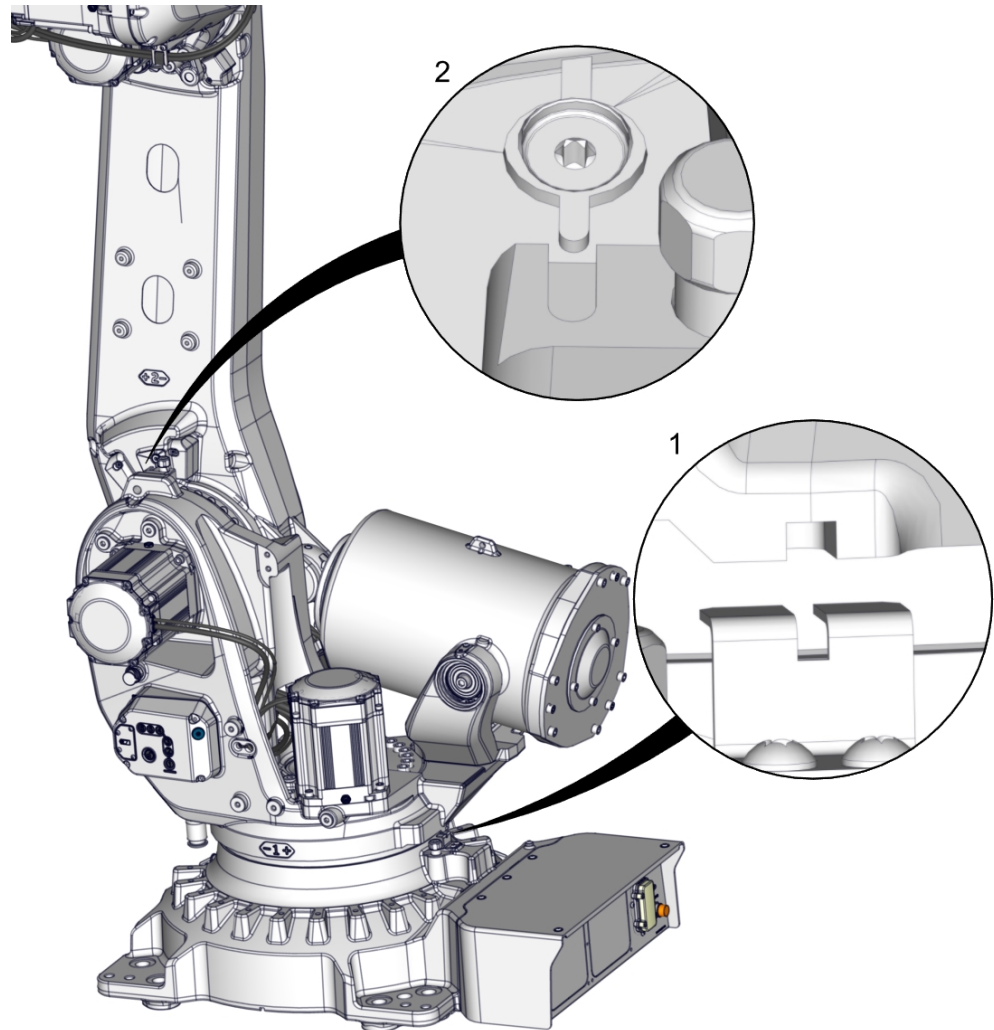

xx2200002087

*Continues on next page*

## 2 Technical data for IRB 6710

### 2.6.2 Synchronization marks and synchronization position for axes

Continued

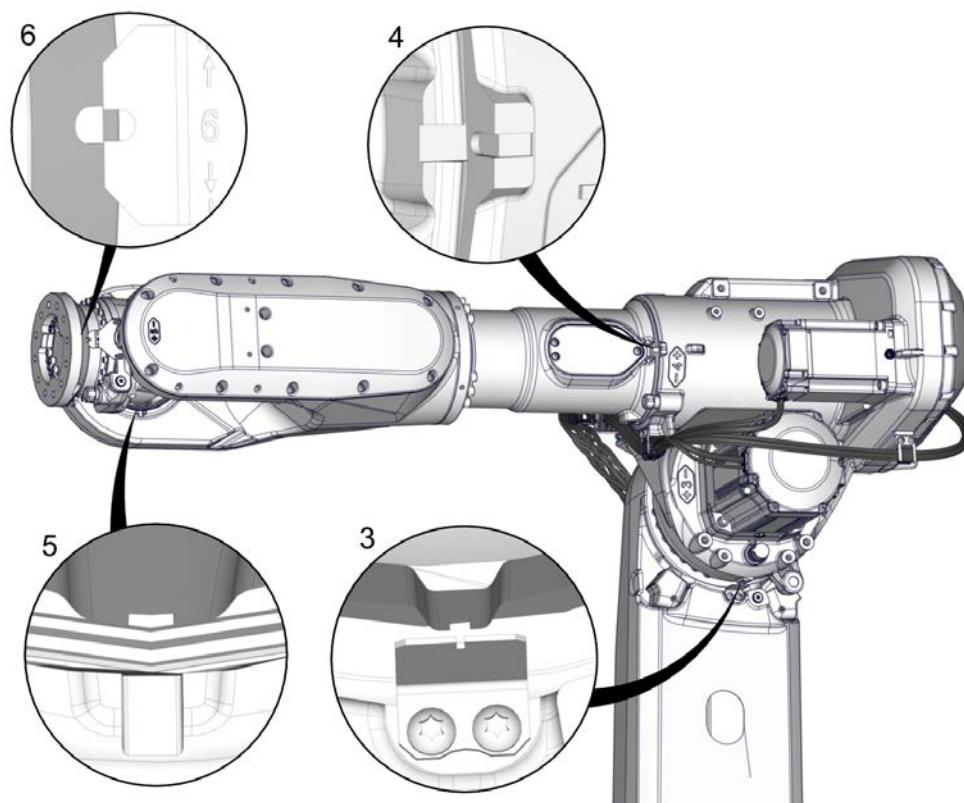

xx2200002088

### 2.6.3 Calibration movement directions for all axes

#### Overview

When calibrating, the axis must consistently be run towards the calibration position in the same direction in order to avoid position errors caused by backlash in gears and so on. Positive directions are shown in the graphic below.

Calibration service routines will handle the calibration movements automatically and these might be different from the positive directions shown below.

#### Manual movement directions

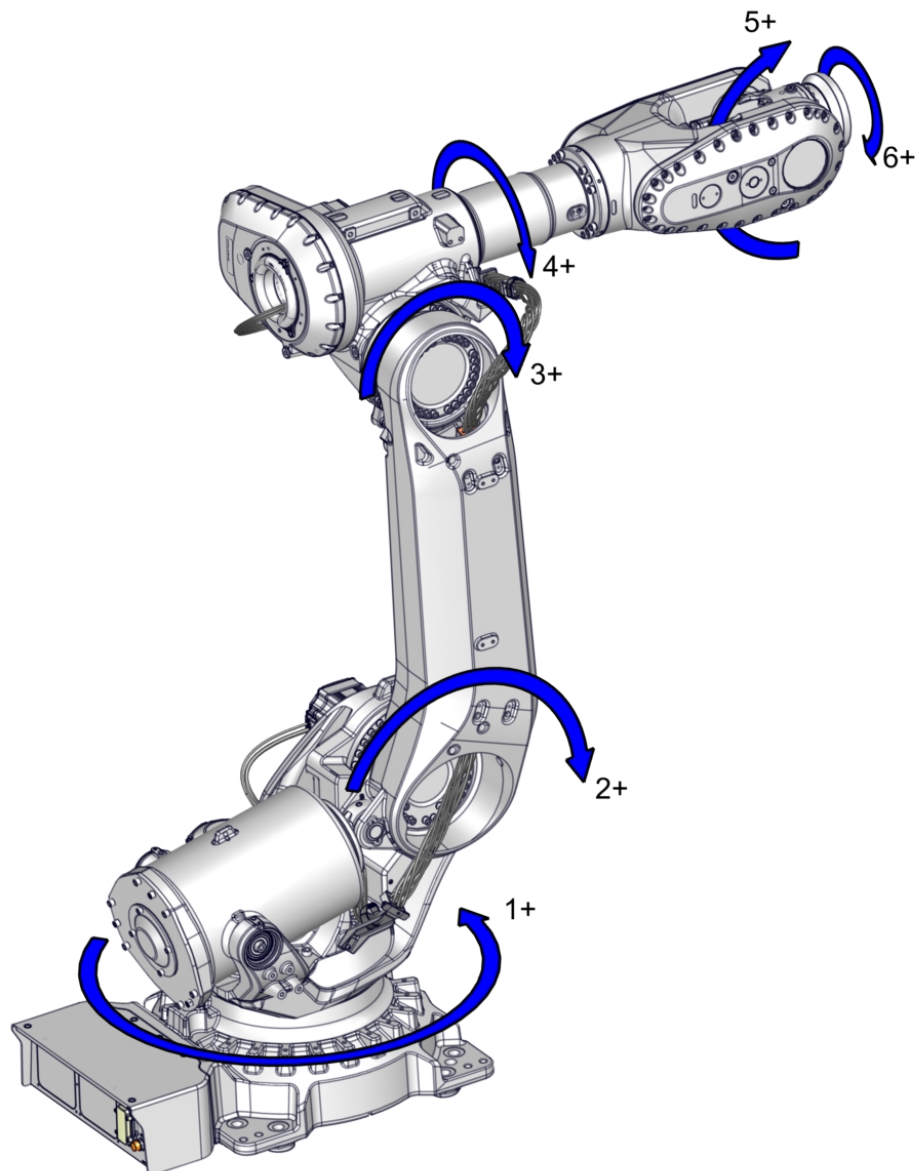

xx2200002089

## 2 Technical data for IRB 6710

### 2.6.4 Fine calibration

### 2.6.4 Fine calibration

#### Recommended method

Fine calibration for the IRB 6710 is done with the Axis Calibration method.

#### Installation locations for the calibration tools

The figure shows the locations for the fixed calibration pins and/or bushings on each axis. Installed calibration tools are not shown.

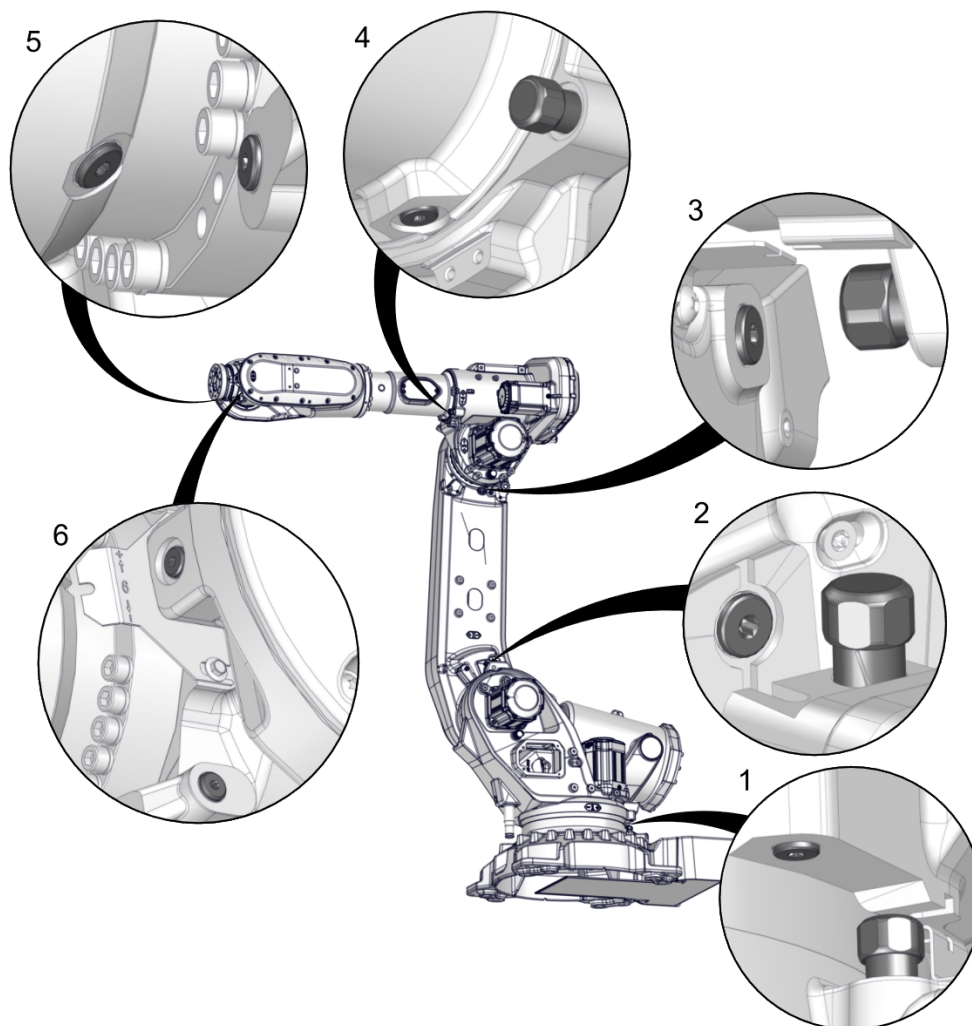

xx2300000257

More information about the Axis Calibration method is found in the product manual for the manipulator.

2.6.5 Calibration tools for Axis Calibration

Calibration tools



**WARNING**

If any part is missing or damaged, the tool must be replaced immediately.

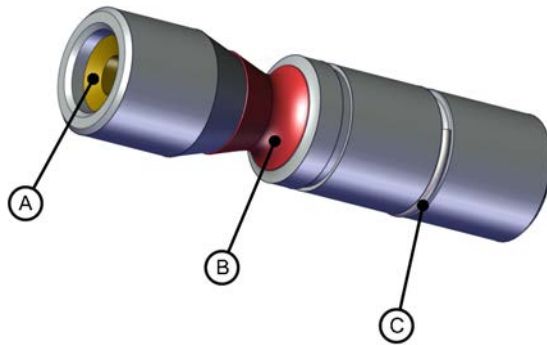

xx1500001914

A	Tube insert
B	Plastic protection
C	Steel spring ring

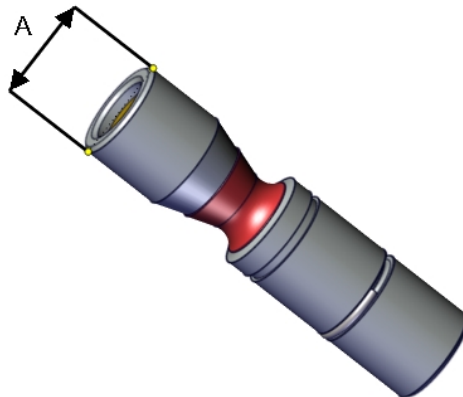

xx1500000951

A	Outer diameter
---	----------------

If including the calibration tool in a local periodic check system, the following measures should be checked.

- Outer diameter within  $\varnothing 12g4$  mm,  $\varnothing 8g4$  mm or  $\varnothing 6g5$  mm (depending on calibration tool size).
- Straightness within 0.005 mm.

#### 2.6.6 Absolute Accuracy calibration

---

##### Purpose

*Absolute Accuracy* is a calibration concept that improves TCP accuracy. The difference between an ideal robot and a real robot can be several millimeters, resulting from mechanical tolerances and deflection in the robot structure. *Absolute Accuracy* compensates for these differences.

Here are some examples of when this accuracy is important:

- Exchangeability of robots
- Offline programming with no or minimum touch-up
- Online programming with accurate movement and reorientation of tool
- Programming with accurate offset movement in relation to eg. vision system or offset programming
- Re-use of programs between applications

The option *Absolute Accuracy* is integrated in the controller algorithms and does not need external equipment or calculation.



##### Note

The performance data is applicable to the corresponding RobotWare version of the individual robot.

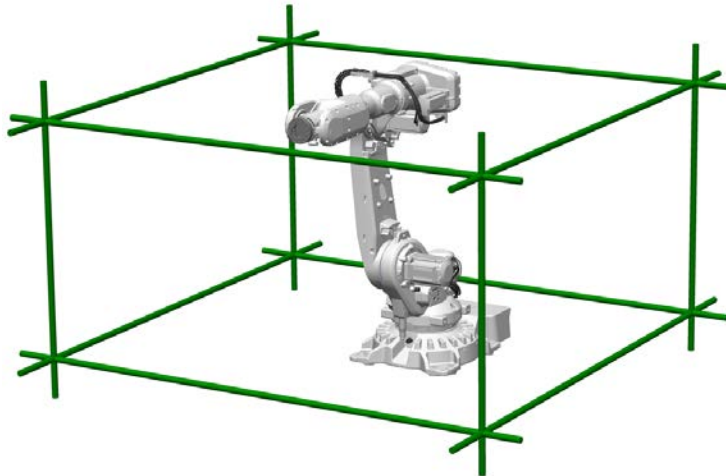

xx2100002472

---

##### What is included

Every *Absolute Accuracy* robot is delivered with:

- compensation parameters saved on the robot's serial measurement board
- a birth certificate representing the *Absolute Accuracy* measurement protocol for the calibration and verification sequence.

A robot with *Absolute Accuracy* calibration has a label with this information on the manipulator.

*Continues on next page*

Absolute Accuracy supports floor mounted installations. Compensation parameters saved in the robot's serial measurement board differ depending on which Absolute Accuracy option is selected.

---

#### **RAPID instructions**

There are no RAPID instructions included in this option.

## 2 Technical data for IRB 6710

### 2.7.1 Introduction

## 2.7 Load diagrams

### 2.7.1 Introduction



#### WARNING

It is very important to always define correct actual load data and correct payload of the robot. Incorrect definitions of load data can result in overloading of the robot.

If incorrect load data and/or loads are outside load diagram is used the following parts can be damaged due to overload:

- motors
- gearboxes
- mechanical structure
- controller drive system



#### WARNING

In the robot system the service routine LoadIdentify is available, which allows the user to make an automatic definition of the tool and load, to determine correct load parameters.

See *Operating manual - OmniCore*, for detailed information.



#### WARNING

Robots running with incorrect load data and/or with loads outside diagram, will not be covered by robot warranty.

### Nominal payload inertia and extra load

The load diagram for each robot variant includes a nominal payload inertia ( $J_0$ ), as specified in the table.

Robot variant	Nominal payload inertia, $J_0$	Extra load
IRB 6710-210/2.65 IRB 6710-200/2.95	15 kgm <sup>2</sup>	50 kg
IRB 6710-175/2.65 LID IRB 6710-175/2.95 LID	15 kgm <sup>2</sup>	LeanID SW

At different moment of inertia the load diagram will be changed.

### Control of load case by "RobotLoad"

To verify a specific load case, use the RobotStudio add-in RobotLoad.

*Continues on next page*

The result from RobotLoad is only valid within the maximum loads and tilt angles. There is no warning if the maximum permitted arm load is exceeded. For over-load cases and special applications, contact ABB for further analysis.

## 2 Technical data for IRB 6710

### 2.7.2 Diagrams

### 2.7.2 Diagrams

#### Diagrams of IRB 6710-210/2.65

Arm load for upper arm: 50 kg.

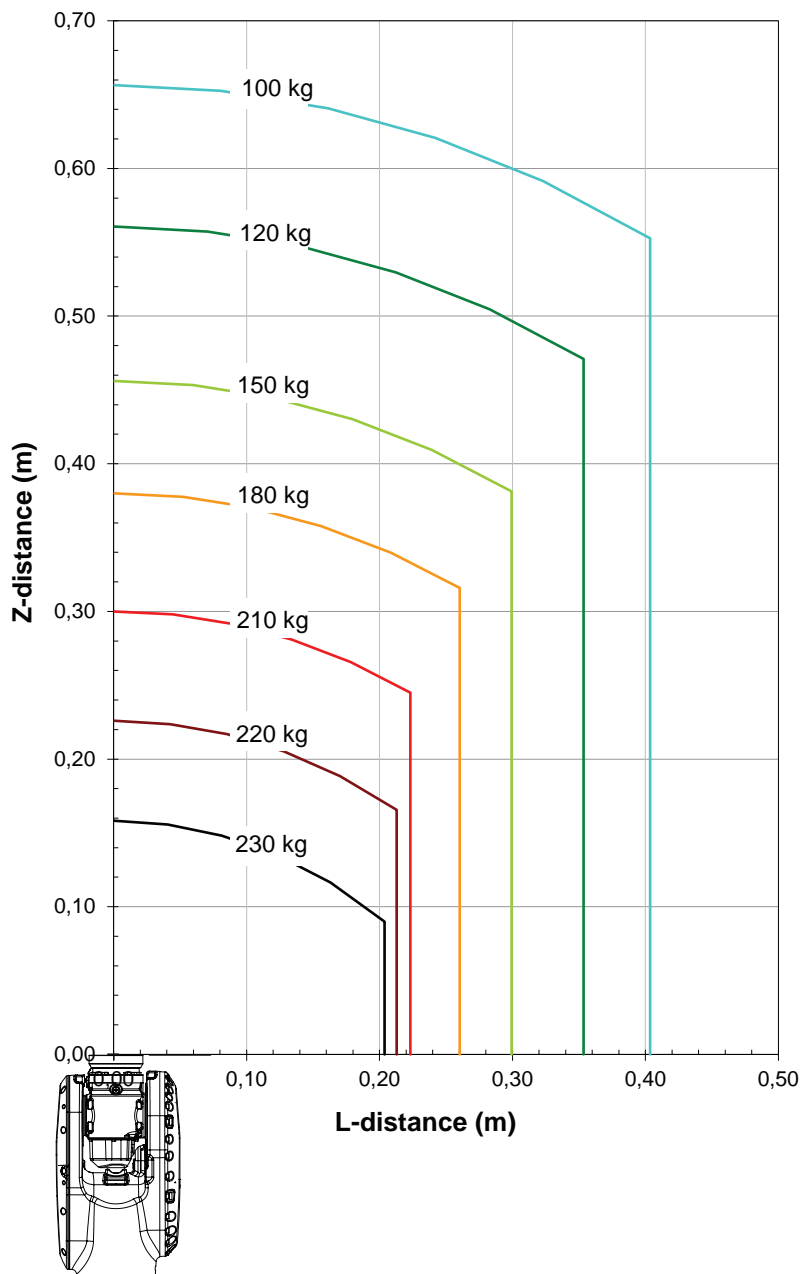

xx2200002154

Continues on next page

Diagrams of IRB 6710-210/2.65"Vertical Wrist" ( $\pm 10^\circ$ )

Arm load for upper arm: 50 kg.

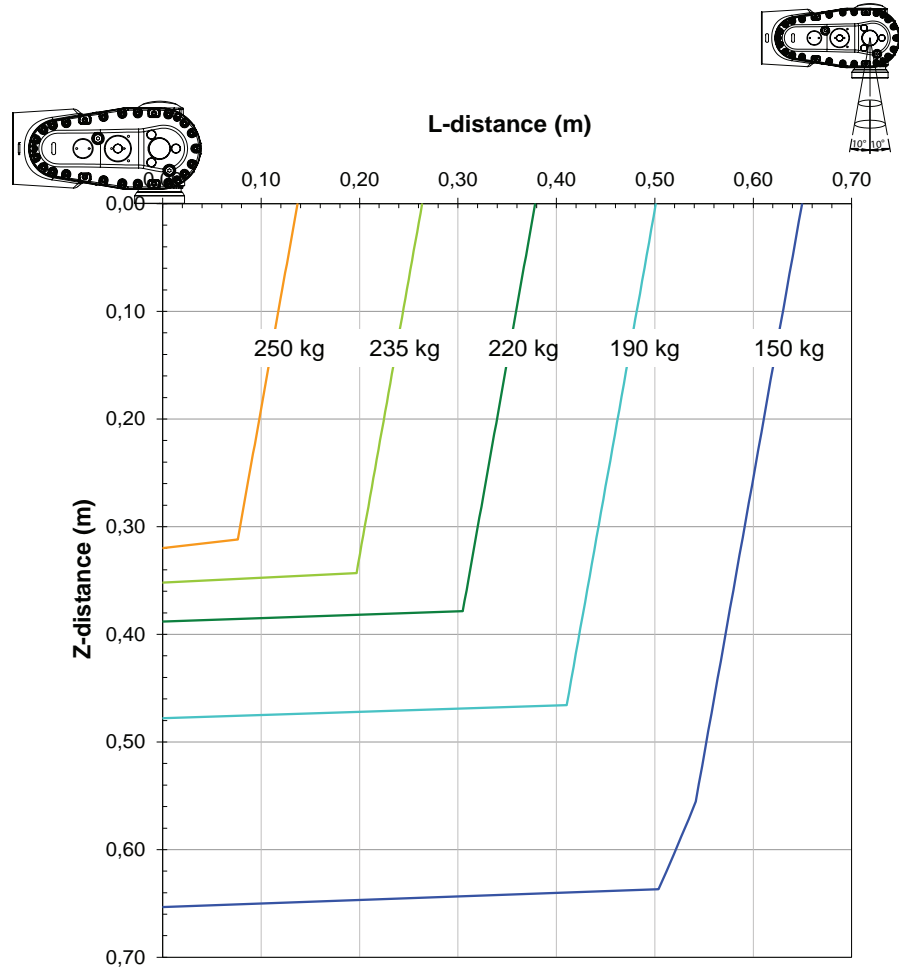

xx2200002155

For wrist down ( $0^\circ$  deviation from the vertical line).

	Description
Max load	290 kg
Z <sub>max</sub>	0.251 m
L <sub>max</sub>	0.058 m

Continues on next page

## 2 Technical data for IRB 6710

### 2.7.2 Diagrams

Continued

#### Diagrams of IRB 6710-200/2.95

Arm load for upper arm: 50 kg.

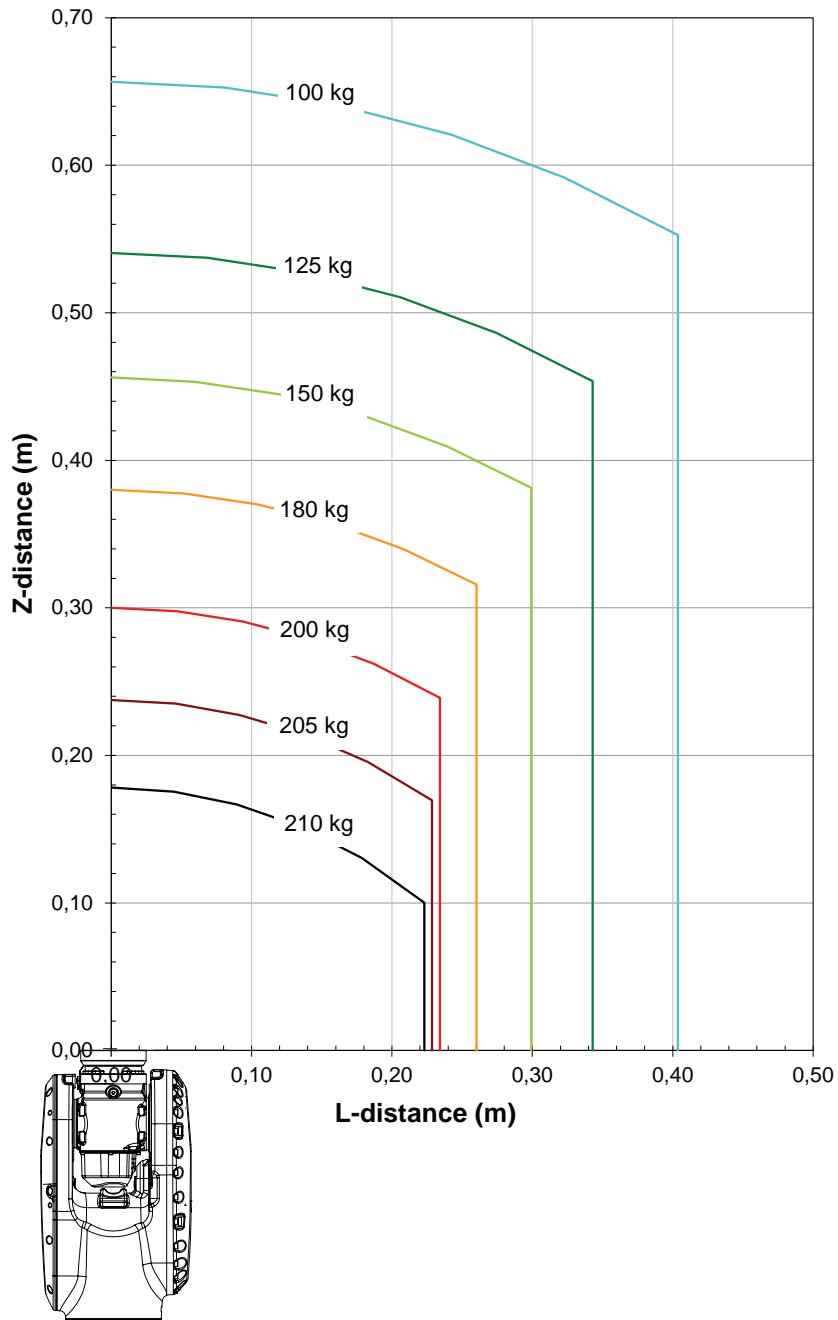

xx2200002156

Continues on next page

Diagrams of IRB 6710-200/2.95"Vertical Wrist" ( $\pm 10^\circ$ )

Arm load for upper arm: 50 kg.

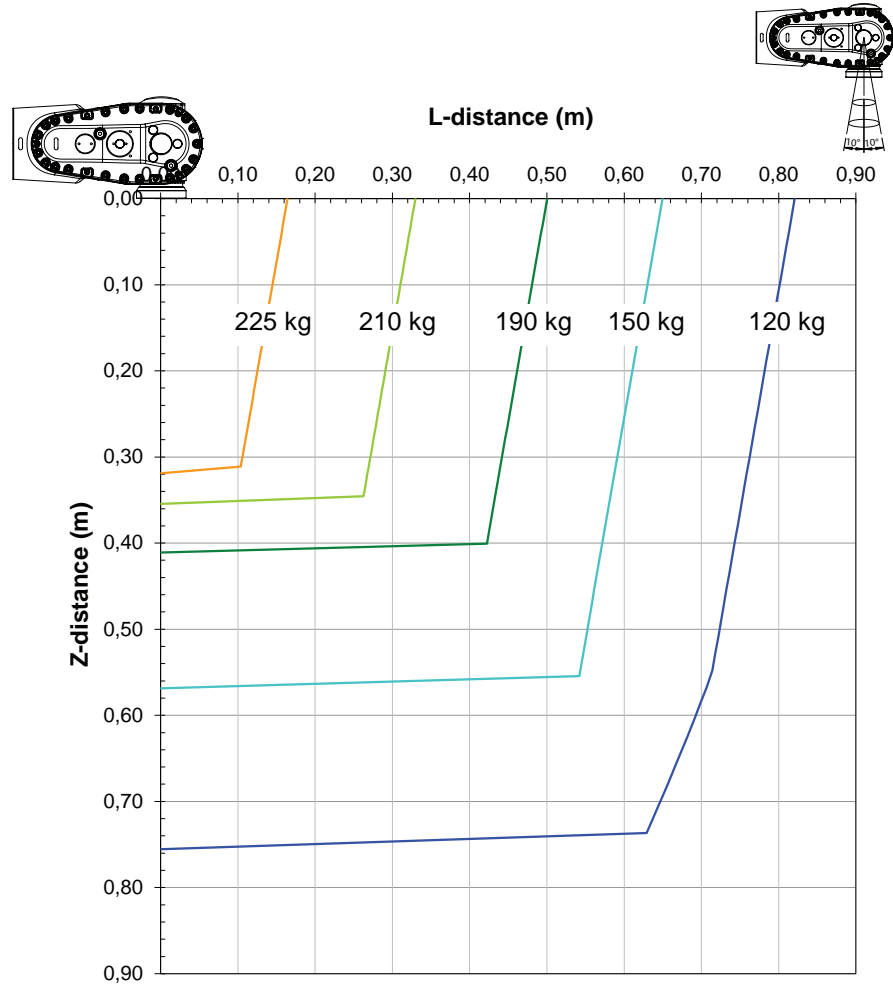

xx2200002157

For wrist down ( $0^\circ$  deviation from the vertical line).

	Description
Max load	260 kg
Z <sub>max</sub>	0.252 m
L <sub>max</sub>	0.063 m

Continues on next page

## 2 Technical data for IRB 6710

### 2.7.2 Diagrams

Continued

#### Diagrams of IRB 6710-175/2.65 LID

With option [3326-x]. Arm load: LeanID SW.

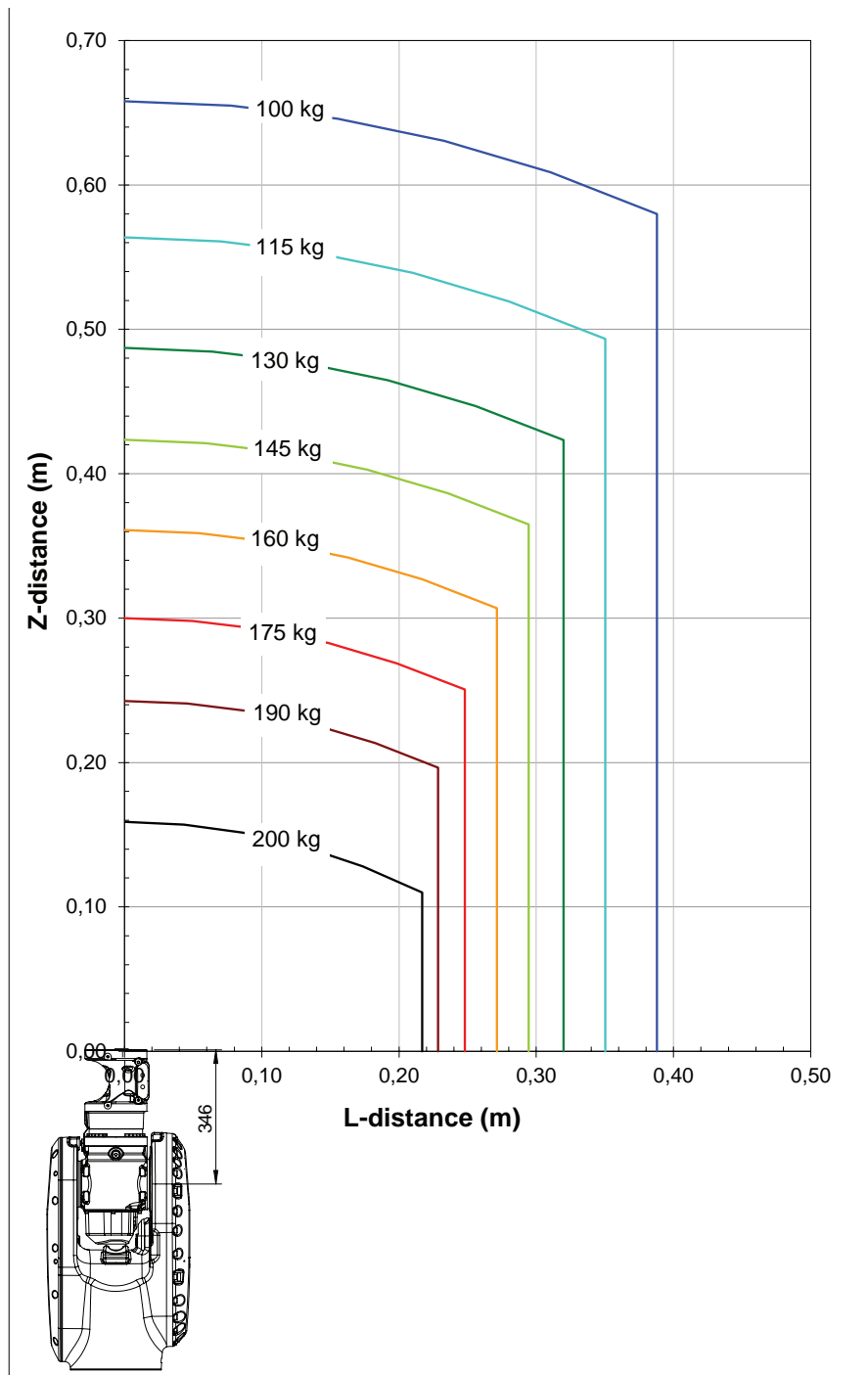

xx2200002158

Continues on next page

Diagrams of IRB 6710-175/2.65 LID ("Vertical Wrist" ( $\pm 10^\circ$ ))  
With option [3326-x]. Arm load: LeanID SW.

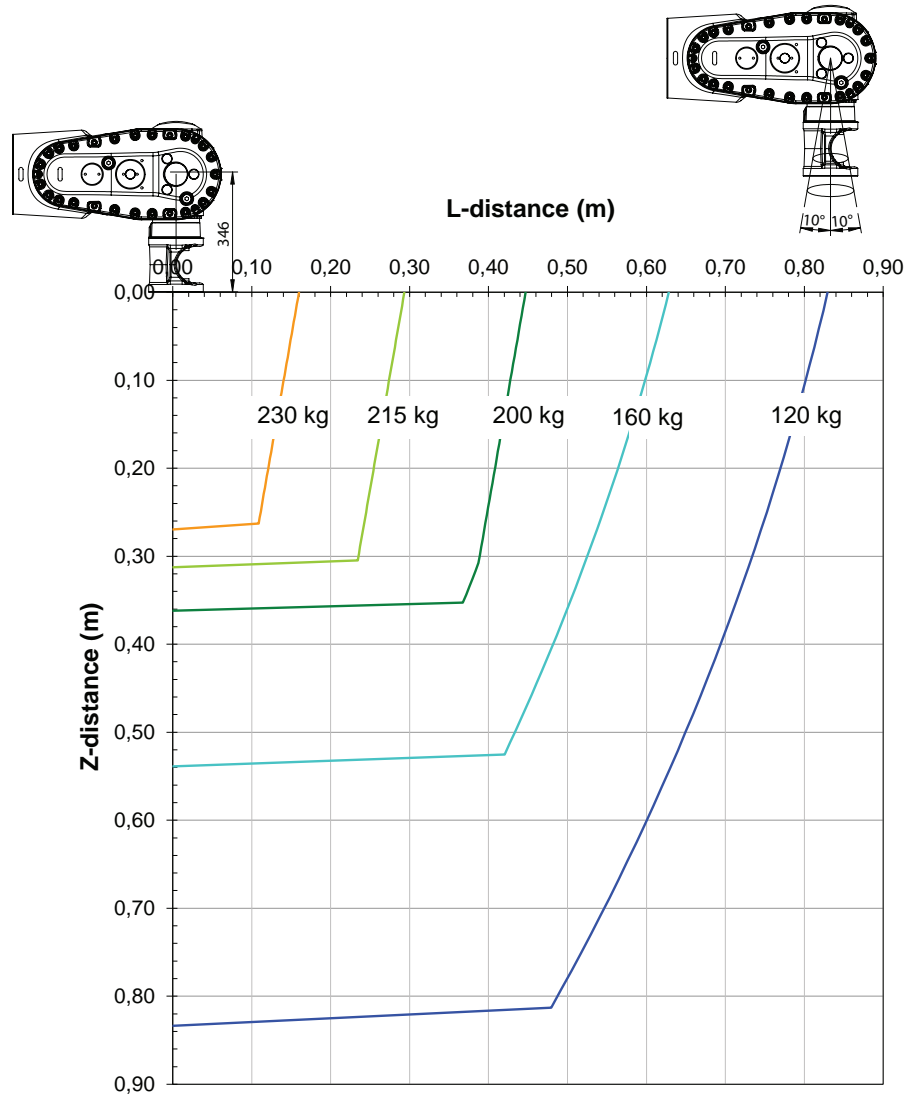

xx2200002159

For wrist down ( $0^\circ$  deviation from the vertical line).

	Description
Max load	250 kg
Z <sub>max</sub>	0.22 m
L <sub>max</sub>	0.064 m

Continues on next page

## 2 Technical data for IRB 6710

### 2.7.2 Diagrams

Continued

#### Diagrams of IRB 6710-175/2.95 LID

With option [3326-x]. Arm load: LeanID SW.

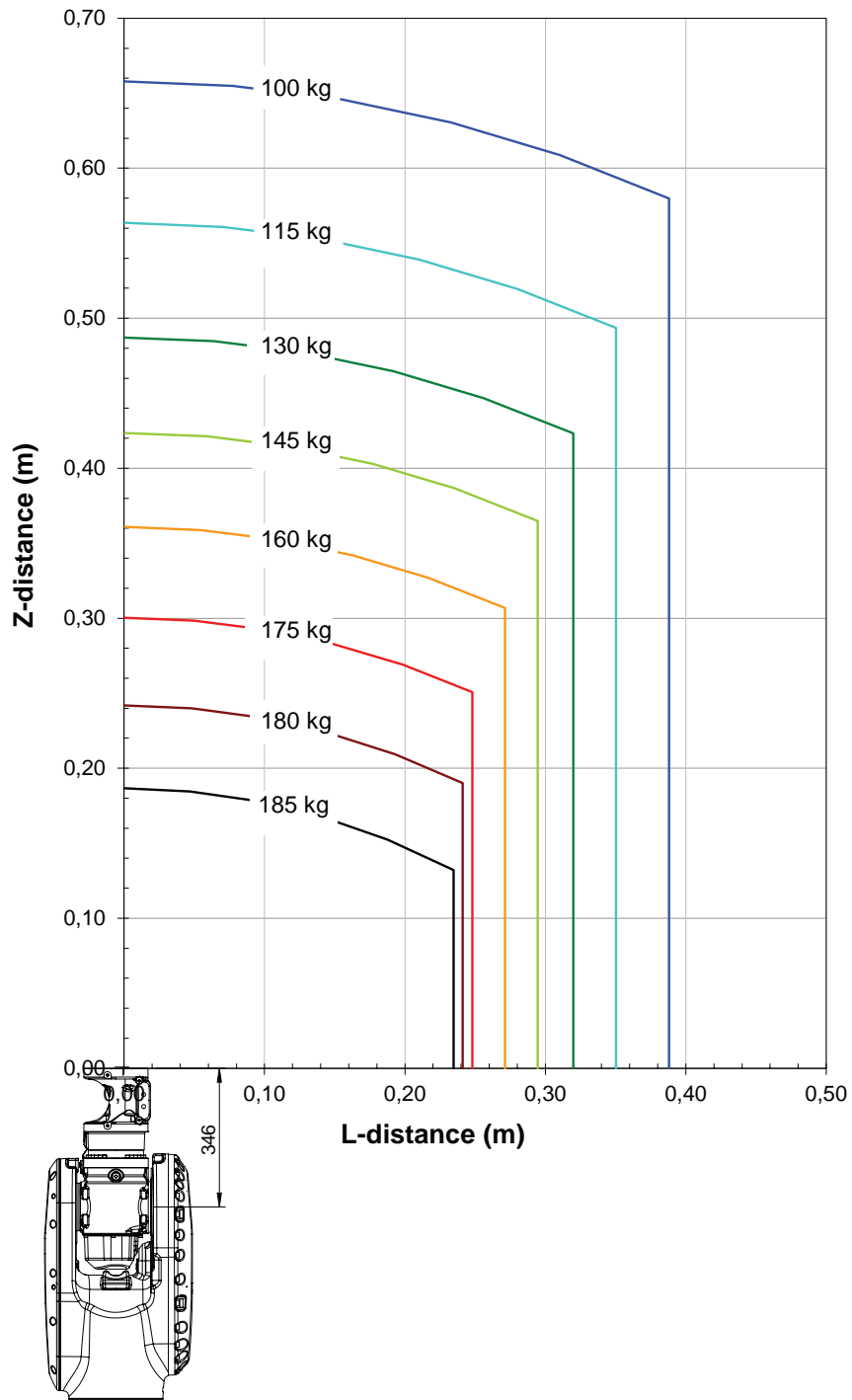

xx2200002160

Continues on next page

Diagrams of IRB 6710-175/2.95 LID ("Vertical Wrist" ( $\pm 10^\circ$ ))  
With option [3326-x]. Arm load: LeanID SW.

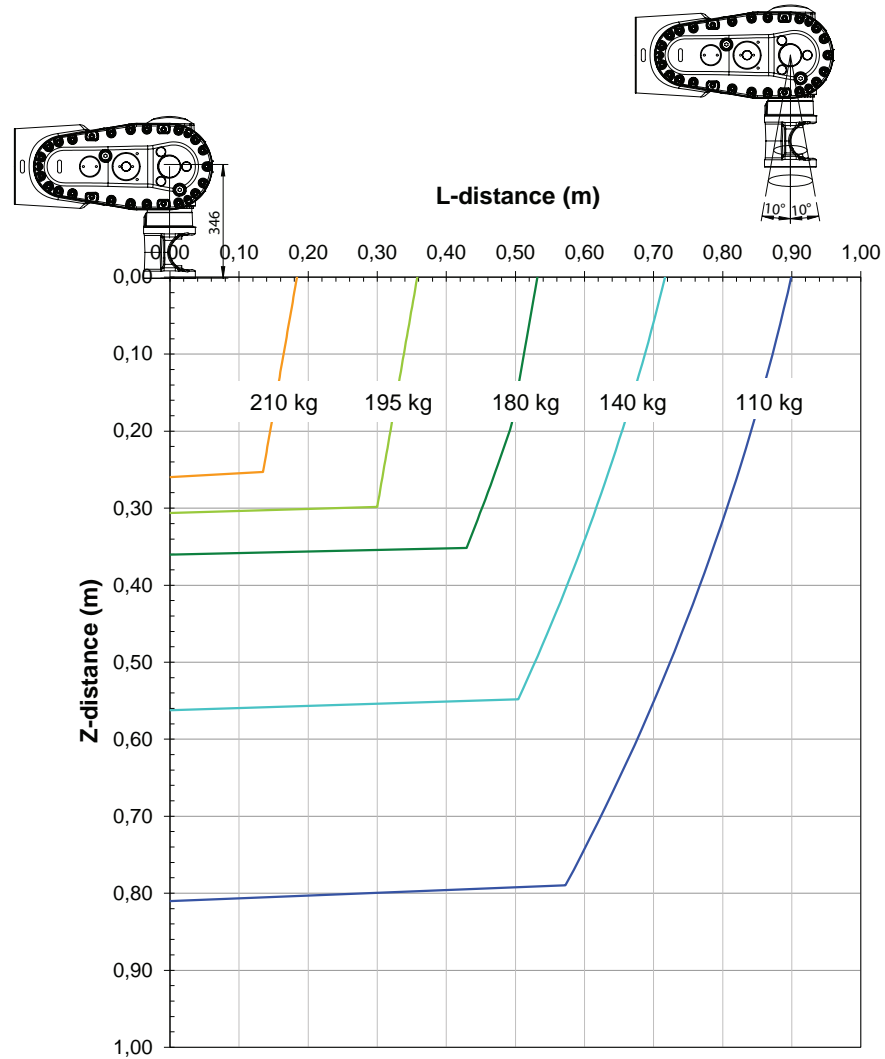

xx2200002161

For wrist down ( $0^\circ$  deviation from the vertical line).

	Description
Max load	230 kg
Z <sub>max</sub>	0.207 m
L <sub>max</sub>	0.047 m

Continues on next page

## 2 Technical data for IRB 6710

### 2.7.3 Maximum load and moment of inertia for full and limited axis 5 (center line down) movement Continued

### 2.7.3 Maximum load and moment of inertia for full and limited axis 5 (center line down) movement



#### Note

Total load given as: mass in kg, center of gravity (Z and L) in meters and moment of inertia ( $J_{0x}$ ,  $J_{0y}$ ,  $J_{0z}$ ) in  $\text{kgm}^2$ .  $L = \sqrt{X^2 + Y^2}$ , see the following figure.

#### Full movement of axis 5 ( $\pm 130^\circ$ )

Robot variant	Maximum load and moment of inertia	
	Axis 5	Axis 6
IRB 6710-210/2.65	$J_{a5} = \text{Load} \times (Z + 0.18)^2 + \max(J_{0x}, J_{0y}) \leq 195 \text{ kgm}^2$	$J_{a6} = \text{Load} \times L^2 + J_{0z} \leq 145 \text{ kgm}^2$
IRB 6710-200/2.95	$J_{a5} = \text{Load} \times (Z + 0.18)^2 + \max(J_{0x}, J_{0y}) \leq 195 \text{ kgm}^2$	$J_{a6} = \text{Load} \times L^2 + J_{0z} \leq 145 \text{ kgm}^2$
IRB 6710-175/2.65 LID	$J_{a5} = \text{Load} \times (Z + 0.346)^2 + \max(J_{0x}, J_{0y}) \leq 195 \text{ kgm}^2$	$J_{a6} = \text{Load} \times L^2 + J_{0z} \leq 145 \text{ kgm}^2$
IRB 6710-175/2.95 LID	$J_{a5} = \text{Load} \times (Z + 0.346)^2 + \max(J_{0x}, J_{0y}) \leq 195 \text{ kgm}^2$	$J_{a6} = \text{Load} \times L^2 + J_{0z} \leq 145 \text{ kgm}^2$

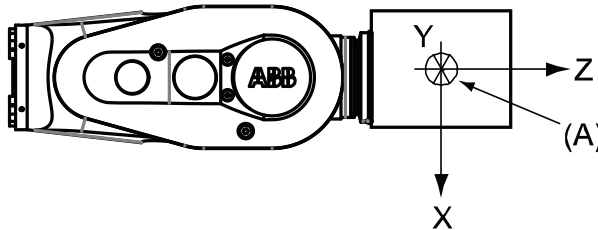

xx1400002028

	Description
A	Center of gravity
	Description
$J_{0x}$ , $J_{0y}$ , $J_{0z}$	Max. moment of inertia around the X, Y and Z axes at center of gravity.

Continues on next page

2.7.3 Maximum load and moment of inertia for full and limited axis 5 (center line down) movement  
Continued

Limited axis 5, center line down

Robot variant	Maximum load and moment of inertia	
	Axis 5	Axis 6
IRB 6710-210/2.65	$J_{a5} = \text{Load} \times (Z + 0.18)^2 + \max(J_{0x}, J_{0y}) \leq 215 \text{ kgm}^2$	$J_{a6} = \text{Load} \times L^2 + J_{0z} \leq 195 \text{ kgm}^2$
IRB 6710-200/2.95	$J_{a5} = \text{Load} \times (Z + 0.18)^2 + \max(J_{0x}, J_{0y}) \leq 215 \text{ kgm}^2$	$J_{a6} = \text{Load} \times L^2 + J_{0z} \leq 195 \text{ kgm}^2$
IRB 6710-175/2.65 LID	$J_{a5} = \text{Load} \times (Z + 0.346)^2 + \max(J_{0x}, J_{0y}) \leq 215 \text{ kgm}^2$	$J_{a6} = \text{Load} \times L^2 + J_{0z} \leq 195 \text{ kgm}^2$
IRB 6710-175/2.95 LID	$J_{a5} = \text{Load} \times (Z + 0.346)^2 + \max(J_{0x}, J_{0y}) \leq 215 \text{ kgm}^2$	$J_{a6} = \text{Load} \times L^2 + J_{0z} \leq 195 \text{ kgm}^2$

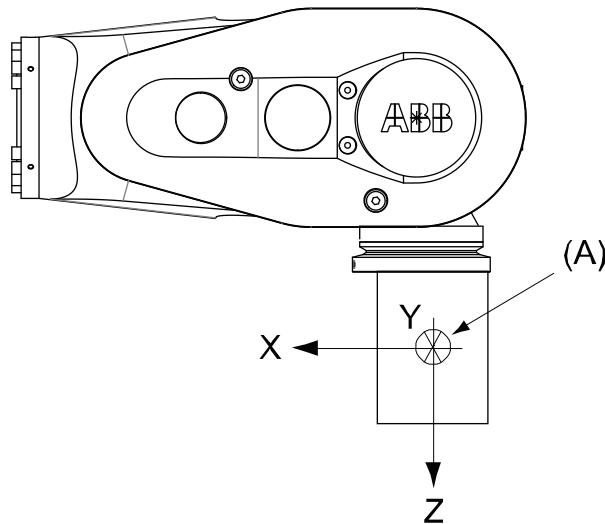

xx140002029

	Description
A	Center of gravity
	Description
$J_{0x}, J_{0y}, J_{0z}$	Max. moment of inertia around the X, Y and Z axes at center of gravity.

## 2 Technical data for IRB 6710

---

### 2.7.4 Wrist torque

### 2.7.4 Wrist torque



#### Note

The wrist torque values are for reference only, and should not be used for calculating permitted load offset (position of center of gravity) within the load diagram, since those also are limited by main axes torques as well as dynamic loads. Furthermore, arm loads will influence the permitted load diagram. To find the absolute limits of the load diagram, use the RobotStudio add-in RobotLoad.

---

### Permissible torque

The table below shows the maximum permissible torque due to payload.

Robot variant	Maximum wrist torque axis 4 and 5	Maximum wrist torque axis 6	Load at which the maximum torques are valid
IRB 6710-210/2.65	989 Nm	460 Nm	180 kg
IRB 6710-200/2.95	989 Nm	460 Nm	180 kg
IRB 6710-175/2.65 LID	1,120 Nm	426 Nm	155 kg
IRB 6710-175/2.95 LID	1,120 Nm	426 Nm	155 kg

## 2.7.5 Maximum TCP acceleration

### General

Higher values can be reached with lower loads than the nominal because of our dynamical motion control QuickMove2. For specific values in the unique customer cycle, or for robots not listed in the table below, we recommend to use RobotStudio.

### Maximum Cartesian design acceleration for nominal loads

Robot variant	E-stop Max acceleration at nominal load COG [m/s <sup>2</sup> ]	Controlled Motion Max acceleration at nominal load COG [m/s <sup>2</sup> ]
IRB 6710-210/2.65	48	24
IRB 6710-200/2.95	45	23
IRB 6710-175/2.65 LID	49	27
IRB 6710-175/2.95 LID	46	27



#### Note

Acceleration levels for emergency stop and controlled motion includes acceleration due to gravitational forces. Nominal load is defined with nominal mass and cog with max offset in Z and L (see the load diagram).

## 2 Technical data for IRB 6710

### 2.8 Performance according to ISO 9283

### 2.8 Performance according to ISO 9283

#### General

At rated maximum load, maximum offset and 1.6 m/s velocity on the inclined ISO test plane, with all six axes in motion. Values in the table below are the result of measurements using the robots Accuracy mode. The result may differ depending on where in the working range the robot is positioning, velocity, arm configuration, from which direction the position is approached and the load direction of the arm system. Backlashes in gearboxes also affect the result.

The figures for AP, RP, AT and RT are measured according to figure below.

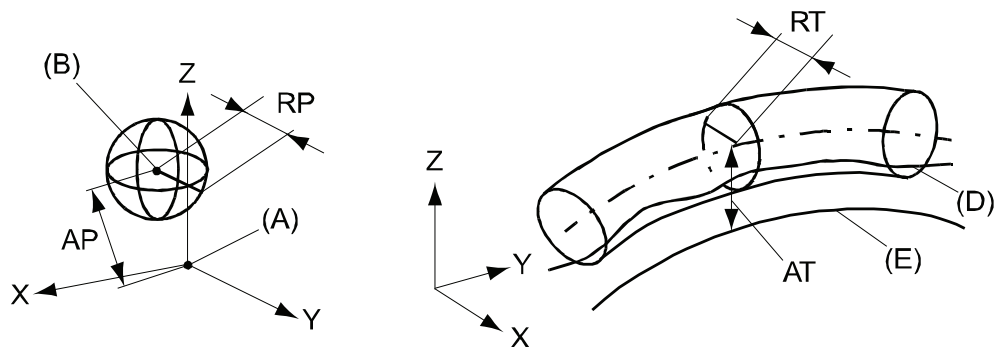

xx080000424

Pos	Description	Pos	Description
A	Programmed position	E	Programmed path
B	Mean position at program execution	D	Actual path at program execution
AP	Mean distance from programmed position	AT	Max deviation from E to average path
RP	Tolerance of position B at repeated positioning	RT	Tolerance of the path at repeated program execution

#### Pose data and path accuracy

Data <sup>i</sup>	IRB 6710-210/2.65	IRB 6710-200/2.95
Pose accuracy, AP (mm) <sup>ii</sup>	0.03	0.01
Pose repeatability, RP (mm)	0.04	0.03
Pose stabilization time, PSt (s) within 0.5 mm of the position	0.1	0.1
Path accuracy, AT (mm)	1.1	0.9
Path repeatability, RT (mm)	0.08	0.09

<sup>i</sup> LID manipulator variants are considered to have the same data as specified variants with the same reach.

<sup>ii</sup> AP according to the ISO test above, is the difference between the taught position (position manually modified in the cell) and the average position obtained during program execution.

## 2.9 Velocity

### Maximum axis speed

Robot variant	Axis 1	Axis 2	Axis 3	Axis 4	Axis 5	Axis 6
IRB 6710-210/2.65	110°/s	110°/s	110°/s	200°/s	150°/s	210°/s
IRB 6710-200/2.95	110°/s	100°/s	90°/s	200°/s	150°/s	210°/s
IRB 6710-175/2.65 LID	110°/s	110°/s	110°/s	200°/s	150°/s	210°/s
IRB 6710-175/2.95 LID	110°/s	100°/s	90°/s	200°/s	150°/s	210°/s

There is a supervision function to prevent overheating in applications with intensive and frequent movements (high duty cycle).

## 2 Technical data for IRB 6710

---

### 2.10.1 Robot stopping distances according to ISO 10218-1

## 2.10 Robot stopping distances and times

### 2.10.1 Robot stopping distances according to ISO 10218-1

---

#### About the data for robot stopping distances and times

All measurements and calculations of stopping distances and times are done according to ISO 10218-1, with single axis motion on axes 1, 2, and 3. If more than one axis is used for the movement, then the stopping distance and time can be longer or shorter. The movement of the axes does not necessarily represent the actual application. Therefore, the braking distance must be validated for each application.

Normal delays of the hardware and software are taken into account. See more about the delays and their impact on the results, [Reading the data on page 90](#).

The stopping distances and times are presented using the tool data and extension zones presented for the respected robot variant. These variables are 100%, 66%, and 33% of the maximum values for the robot.

The stop categories 0 and 1 are according to IEC 60204-1.



#### Note

The category 0 stop is not necessarily the worst case (depending on load, speed, application, wear, etc.).



#### Note

The stop category 1 is a controlled stop and will therefore have less deviation from the programmed path compared with a stop category 0.

---

#### Loads

The tool data that is used is presented for the respective robot variant.

The used loads represent the rated load. No arm load is used. See the [Load diagrams on page 72](#).

*Continues on next page*

Extension zones

The extension zone for the stop category 1 is based on the tool mounting interface (tool flange) with the axis angles according to the following illustrations. The zone data is presented for the respective robot variant.

The extension zone outer limits are defined by the TCP0 position for the stated angles.

Illustration	
Axis 1	<p>xx2300000860</p>
Axis 2	<p>xx2300000861</p>

Continues on next page

## 2 Technical data for IRB 6710

### 2.10.1 Robot stopping distances according to ISO 10218-1

Continued

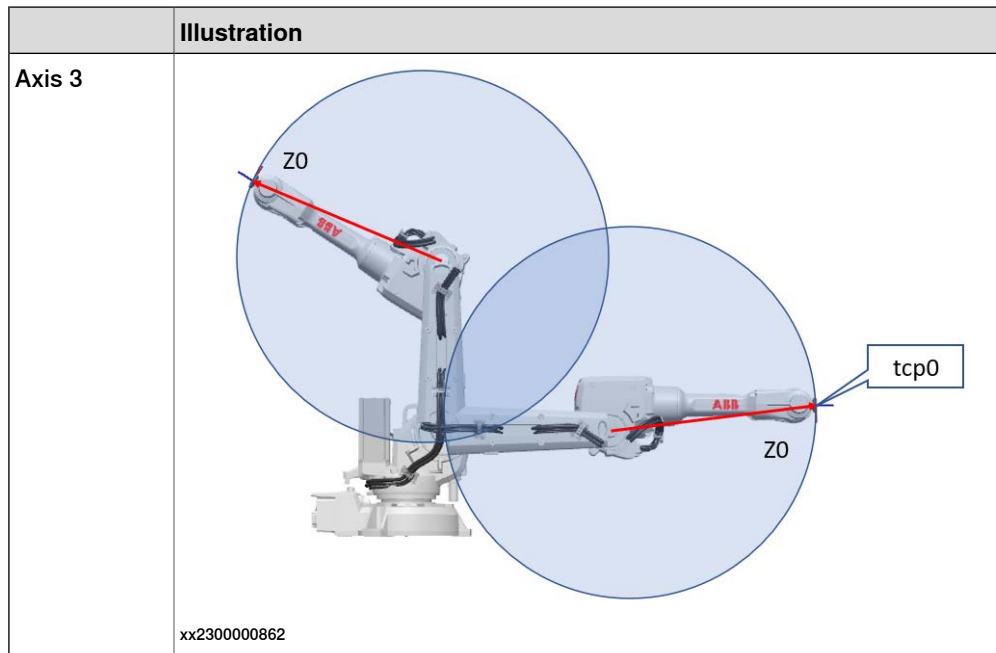

#### Speed

The speed in the simulations is based on TCP0.

The TCP0 speed is measured in meters per second when the stop is triggered.

#### Stopping distances

The stopping distance is measured in degrees.

#### Stopping times

The stopping time is measured in seconds.

#### Limitations

The stopping distance can vary depending on additional loads on the robot.

The stopping distance for category 0 stops can vary depending on the individual brakes and the joint friction.

#### Reading the data

The data for stop category 0 is presented in tables, with distance and time for each axis.

The data for stop category 1 is presented as graphs with curves representing the different loads.

There is a short delay in the stop, which means that if the axis is accelerating when the stop is initiated (C), it will continue to accelerate during this delay time. This can result in graphs where a higher load (A) gives shorter stopping distance than a smaller load (B).

Continues on next page

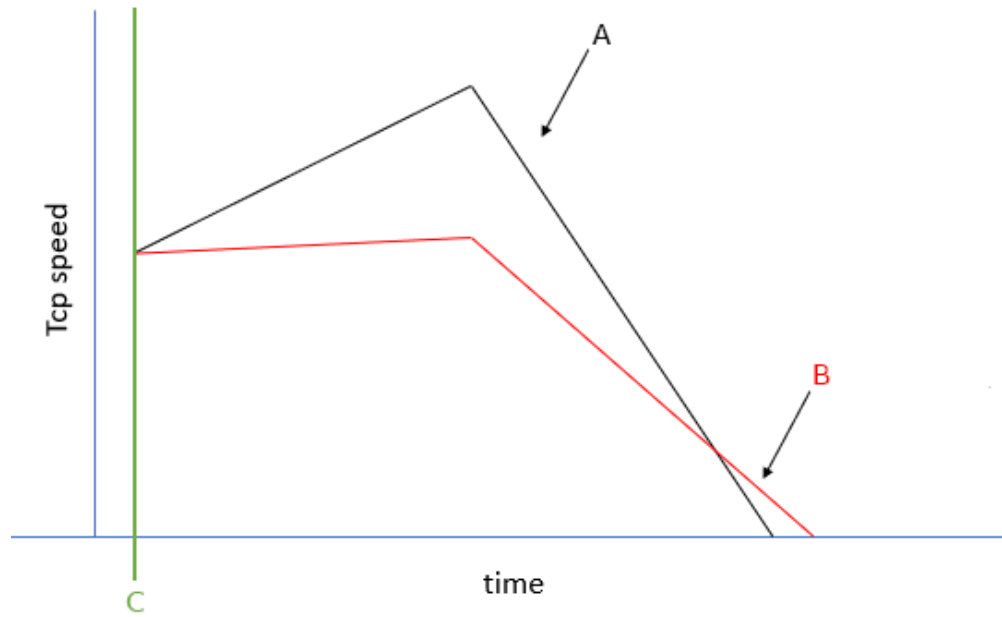

xx2300001041

The tcp speed is the actual speed when the stop is initiated, which is not necessarily the programmed speed.

## 2 Technical data for IRB 6710

---

### 2.10.2 Measuring stopping distance and time

#### 2.10.2 Measuring stopping distance and time

---

##### Preparations before measuring

For measurement and calculation of overall system stopping performance, see ISO 13855:2010.

The measurement shall be done for the selected stop category. The emergency stop button on the robot controller is configured for stop category 0 on delivery. A risk assessment can conclude the need for another stop category. The stop category can be changed through the system parameter *Function* (topic *Controller*, type *Safety Run Chain*). In case of deviations of the default configuration of stop category 0, then this is detailed in the product specification for the respective manipulator.



##### CAUTION

The measurement and calculation of overall stopping performance for a robot must be tested with its correct load, speed, and tools, in its actual environment, before the robot is taken into production.

All load and tool data must be correctly defined (weight, CoG, moment of inertia). The load identification service routine can be used to identify the data.

The measurement and calculation can also be included in a yearly maintenance.



##### CAUTION

Follow the safety instructions in the respective product manual for the robot.

---

##### Measuring with TuneMaster

The software TuneMaster can be used to measure stopping distances and times for ABB robots. The TuneMaster software contains documentation on how to use it.

- 1 Download TuneMaster from [www.abb.com/robotics](http://www.abb.com/robotics), section **RobotStudio - Downloads - RobotWare Tools and Utilities**.
- 2 Install TuneMaster on a computer. Start the TuneMaster app and select **Log Signals**.
- 3 Connect to the robot controller.
- 4 Define the I/O stop signal to use for measurement, for example, ES1 for emergency stop.
- 5 Define the signal number to use for measurement, 1298 for axis position. The value is given in radians.
- 6 Start the logging in TuneMaster.
- 7 Start the test program on the controller.



##### Tip

Use the tool and zone definitions for the respective variant in this document to get results that are comparable with this document.

*Continues on next page*

*Continued*

- 8 When the axis has reached maximum speed, press the emergency stop button.
- 9 In TuneMaster, measure the stopping distance and time.
- 10 Repeat for all installed emergency stop buttons until the identified hazards due to stopping distance and time for axes have been verified.

Example from TuneMaster

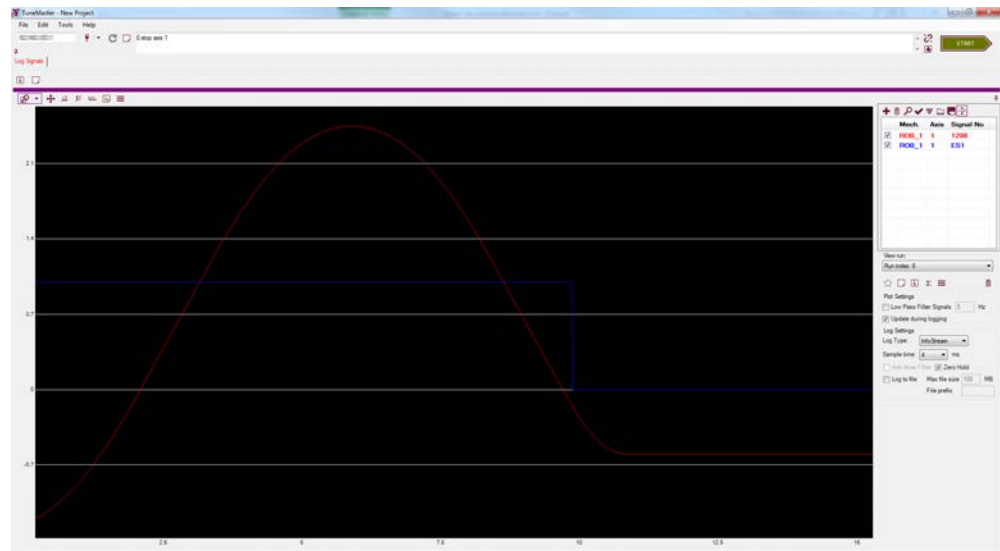

xx160000386

## 2 Technical data for IRB 6710

### 2.10.3 IRB 6710-210/2.65

#### 2.10.3 IRB 6710-210/2.65

##### Used tooldata

```
PERS tooldata P100:= [ TRUE, [[0, 0, 0], [1, 0, 0, 0]], [210, [0, 0, 300], [1, 0, 0, 0], 3.2, 3.2, 3.2]];
PERS tooldata P66:= [ TRUE, [[0, 0, 0], [1, 0, 0, 0]], [140, [0, 0, 200], [1, 0, 0, 0], 1.4, 1.4, 1.4]];
PERS tooldata P33:= [ TRUE, [[0, 0, 0], [1, 0, 0, 0]], [70, [0, 0, 100], [1, 0, 0, 0], 0.35, 0.35, 0.35]];
```

##### Category 0

The following table describes the stopping distance and time for category 0 stop.

Axis	Distance	Stop time
1	33.0°	0.58 s
2	28.4°	0.43 s
3	21.5°	0.28 s

##### Category 1, extension zones

For definitions of the zones, see [Extension zones on page 89](#).

The zone border is the mounting interface location for axis 2 and axis 3.

##### Axis 1

Zone border	Axis 2	Axis 3
z0-z1	-42°	42°
z1-z2	6°	-6°

##### Axis 2

Zone border	Axis 2	Axis 3
z0-z1	48°	30°
z1-z2	85°	-30°

##### Axis 3

Only one zone exists.

*Continues on next page*

Category 1, Axis 1, Extension zone 0, stopping distance and stopping time

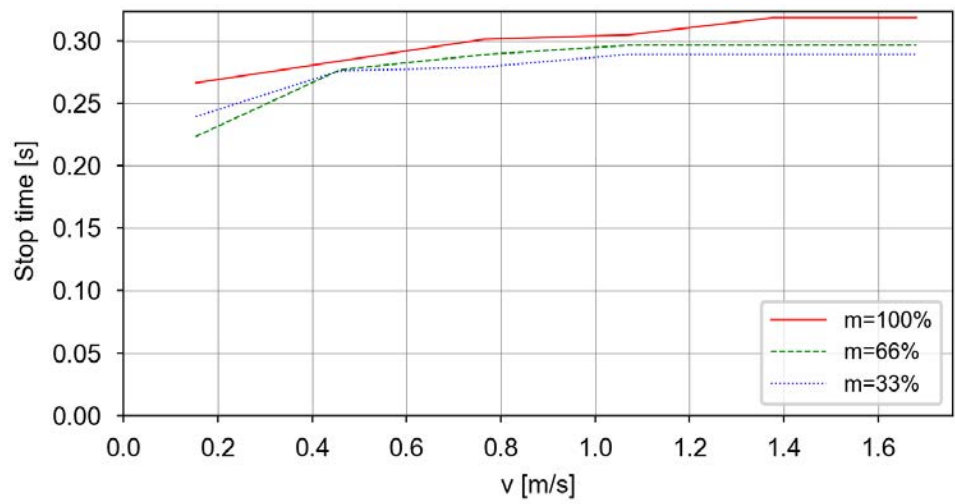
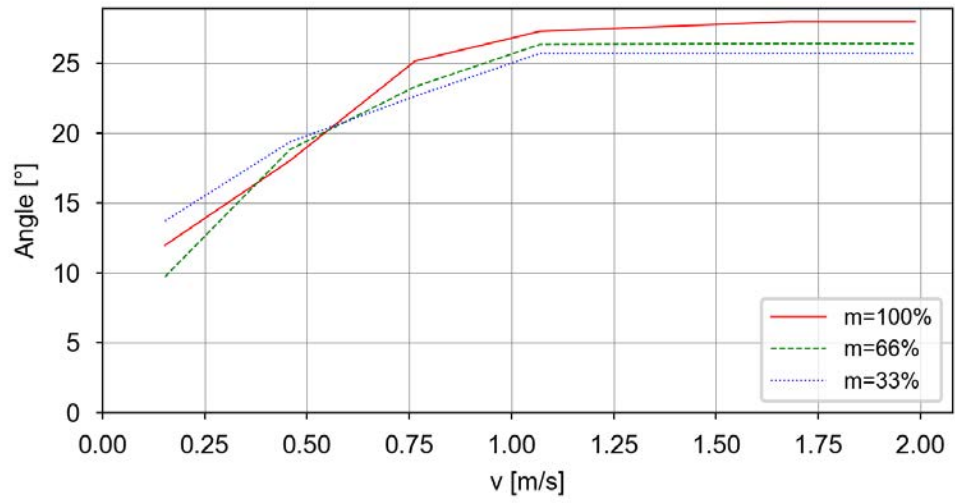

Continues on next page

## 2 Technical data for IRB 6710

### 2.10.3 IRB 6710-210/2.65

Continued

#### Category 1, Axis 1, Extension zone 1, stopping distance and stopping time

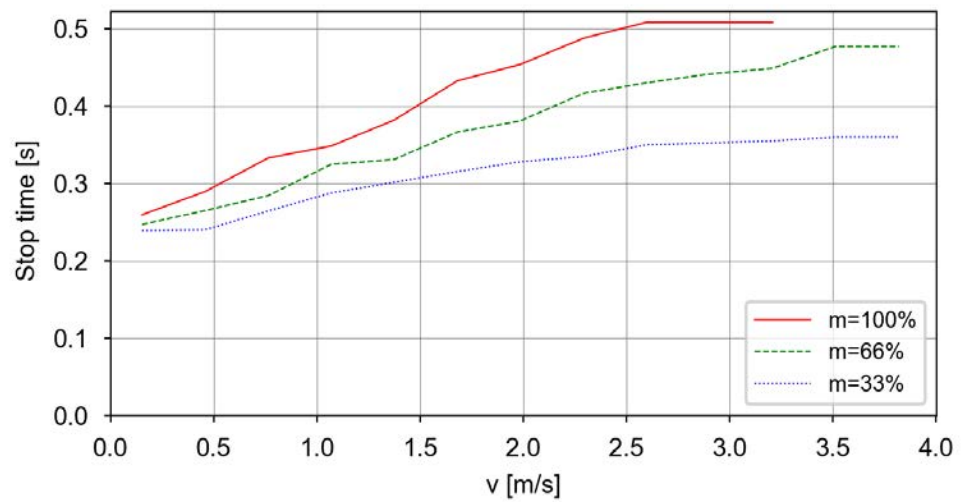
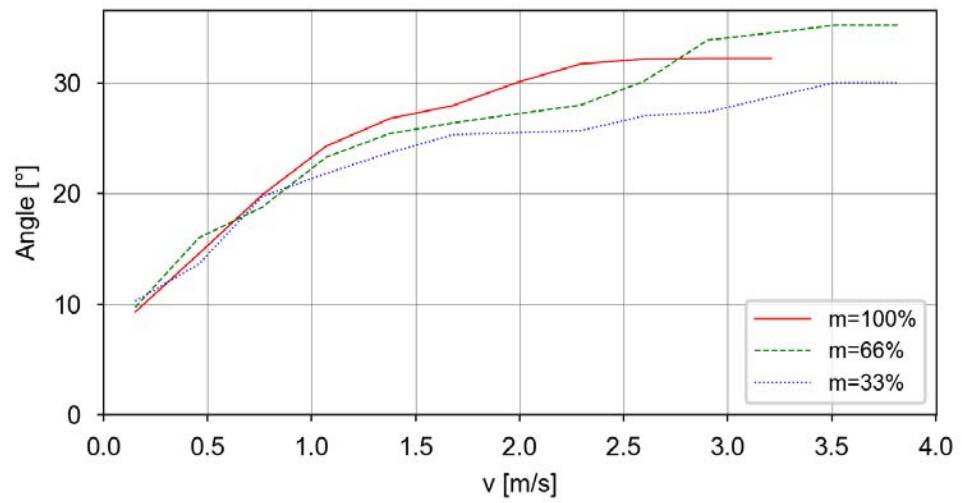

Continues on next page

Category 1, Axis 1, Extension zone 2, stopping distance and stopping time

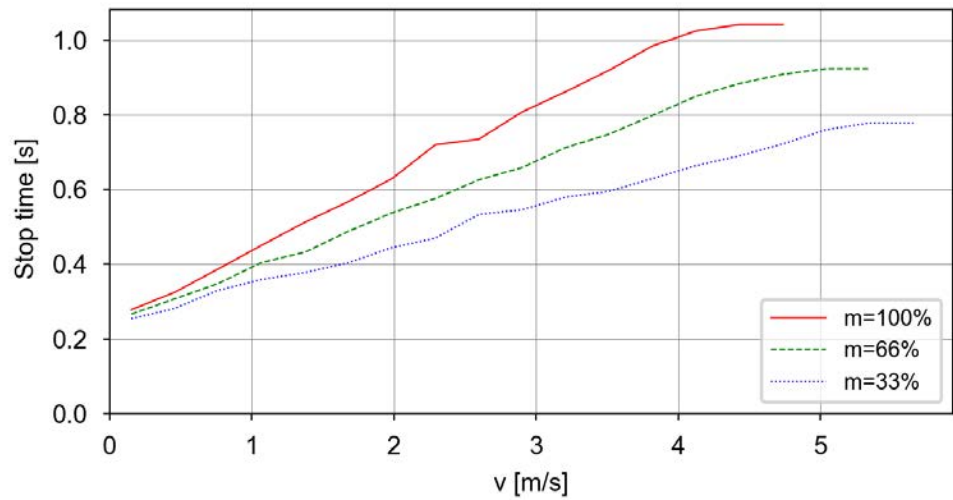
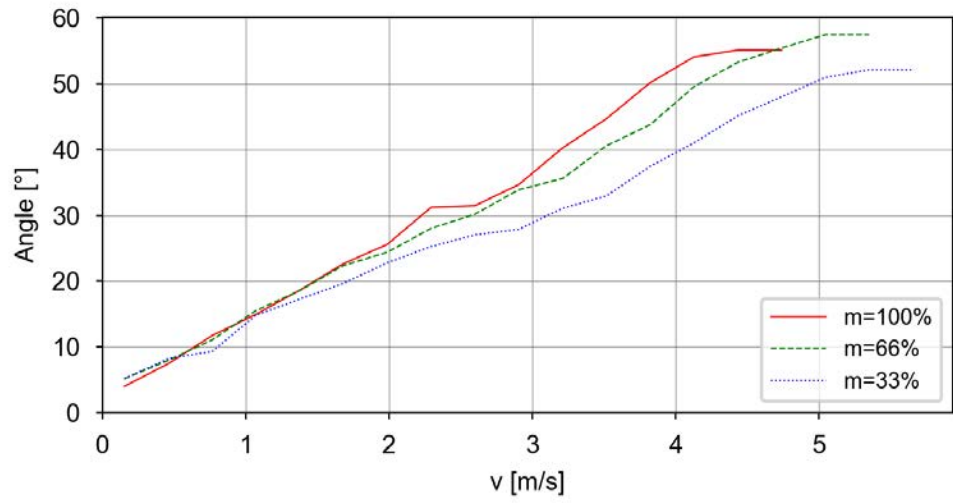

Continues on next page

## 2 Technical data for IRB 6710

### 2.10.3 IRB 6710-210/2.65

Continued

#### Category 1, Axis 2, Extension zone 0, stopping distance and stopping time

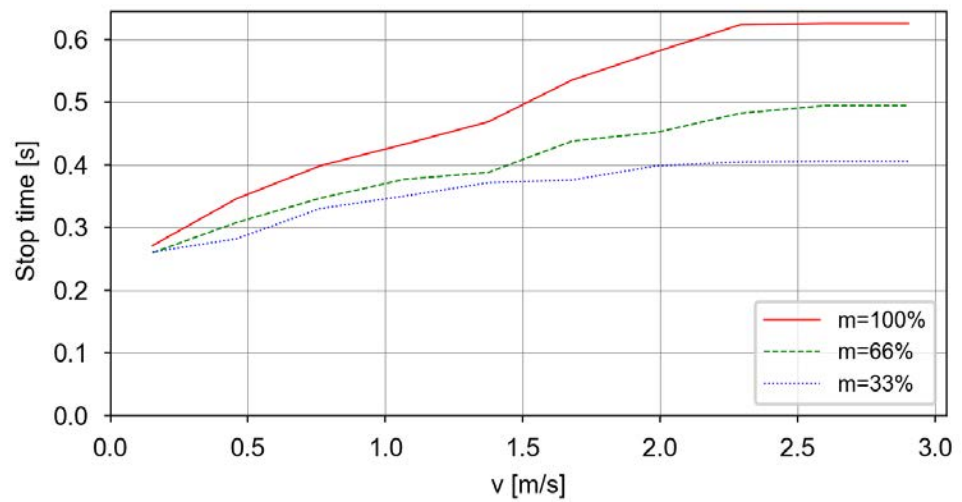
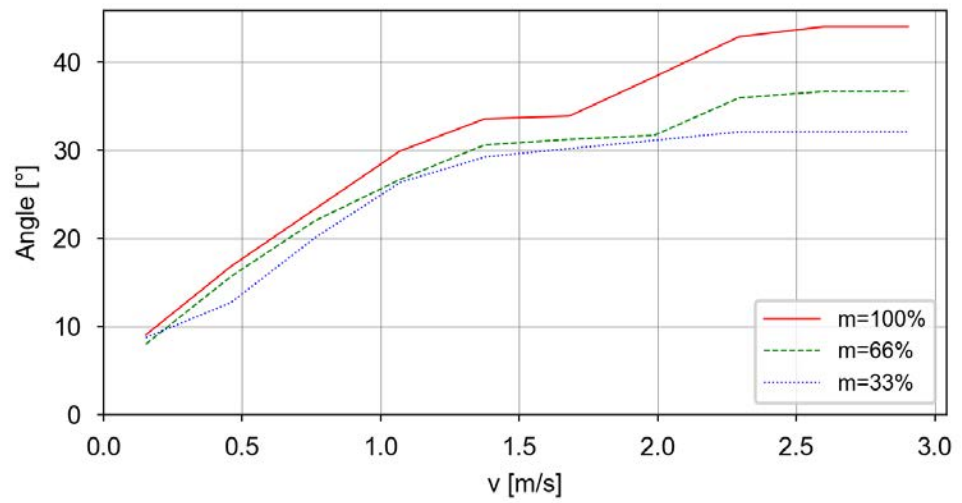

Continues on next page

Category 1, Axis 2, Extension zone 1, stopping distance and stopping time

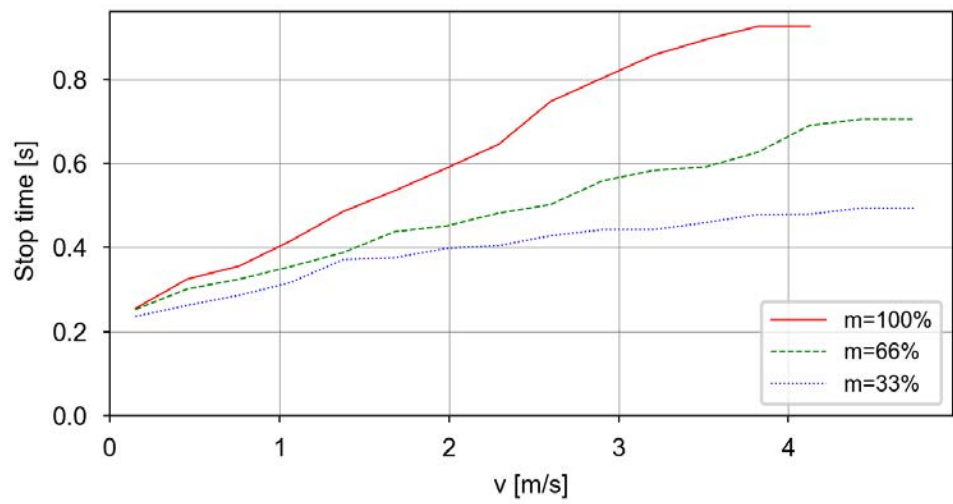
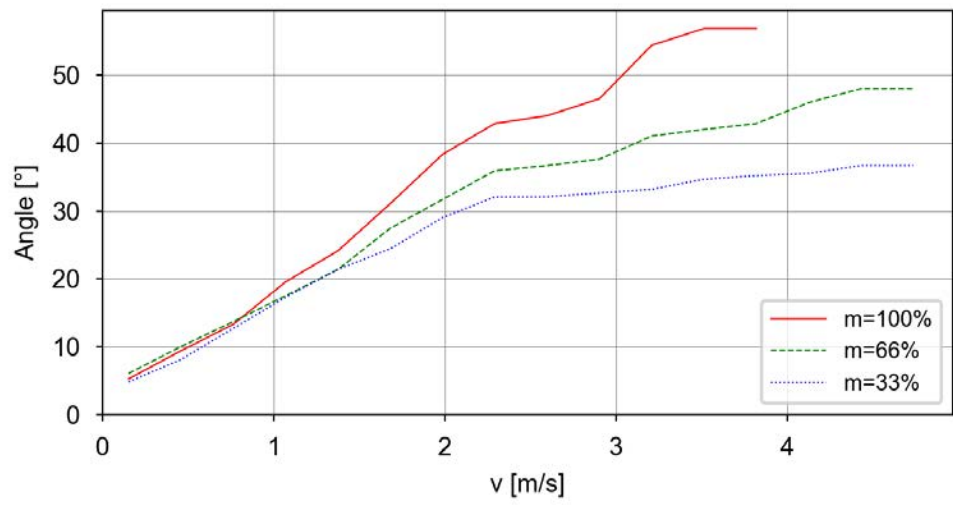

Continues on next page

## 2 Technical data for IRB 6710

### 2.10.3 IRB 6710-210/2.65

Continued

#### Category 1, Axis 2, Extension zone 2, stopping distance and stopping time

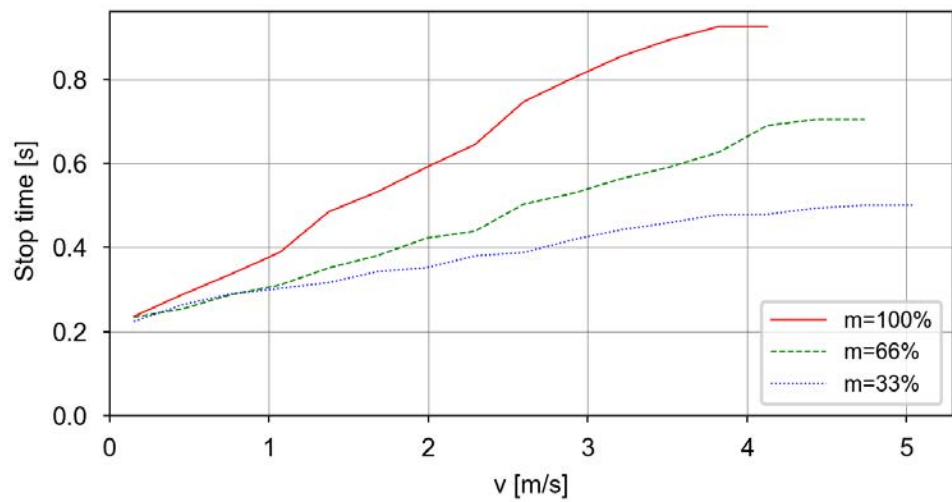
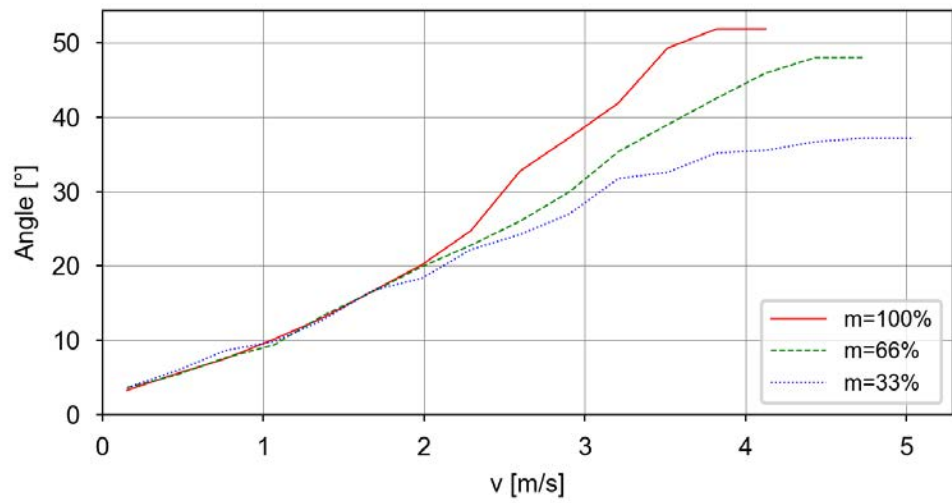

Continues on next page

Category 1, Axis 3, Extension zone 0, stopping distance and stopping time

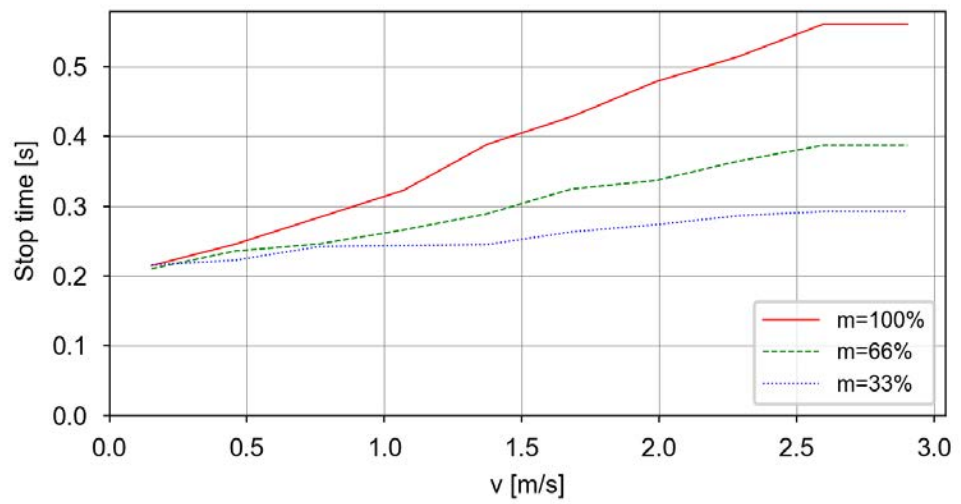
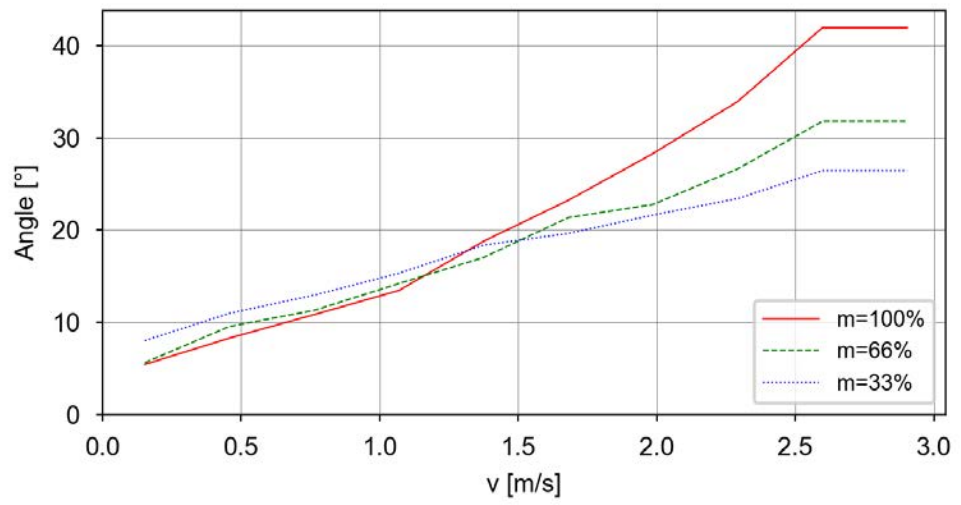

## 2 Technical data for IRB 6710

### 2.10.4 IRB 6710-200/2.95

#### 2.10.4 IRB 6710-200/2.95

##### Used tooldata

```
PERS tooldata P100:= [ TRUE, [[0, 0, 0], [1, 0, 0 ,0]], [200, [0,
0, 300], [1, 0, 0, 0], 3, 3, 3]];
PERS tooldata P66:= [ TRUE, [[0, 0, 0], [1, 0, 0 ,0]], [133, [0,
0, 200], [1, 0, 0, 0], 1.3, 1.3, 1.3]];
PERS tooldata P33:= [ TRUE, [[0, 0, 0], [1, 0, 0 ,0]], [67, [0, 0,
100], [1, 0, 0, 0], 0.33, 0.33, 0.33]];
```

##### Category 0

The following table describes the stopping distance and time for category 0 stop.

Axis	Distance	Stop time
1	33.2°	0.62 s
2	25.6°	0.43 s
3	17.7°	0.27 s

##### Category 1, extension zones

For definitions of the zones, see [Extension zones on page 89](#).

The zone border is the mounting interface location for axis 2 and axis 3.

##### Axis 1

Zone border	Axis 2	Axis 3
z0-z1	-42°	42°
z1-z2	6°	-6°

##### Axis 2

Zone border	Axis 2	Axis 3
z0-z1	48°	30°
z1-z2	85°	-30°

##### Axis 3

Only one zone exists.

*Continues on next page*

Category 1, Axis 1, Extension zone 0, stopping distance and stopping time

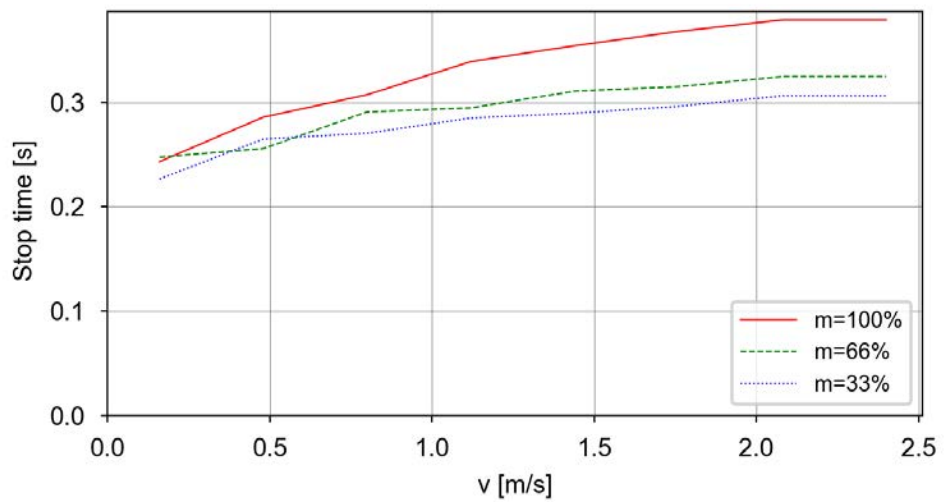
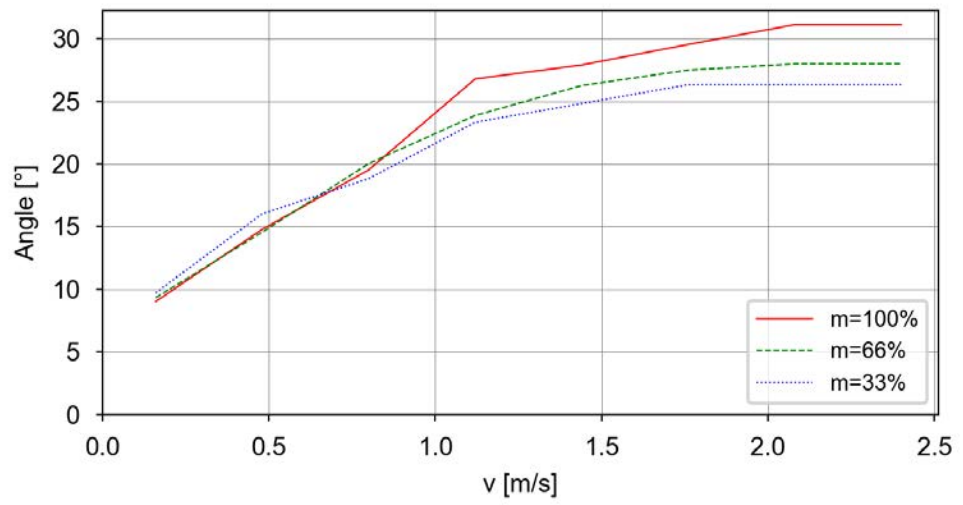

Continues on next page

## 2 Technical data for IRB 6710

### 2.10.4 IRB 6710-200/2.95

Continued

#### Category 1, Axis 1, Extension zone 1, stopping distance and stopping time

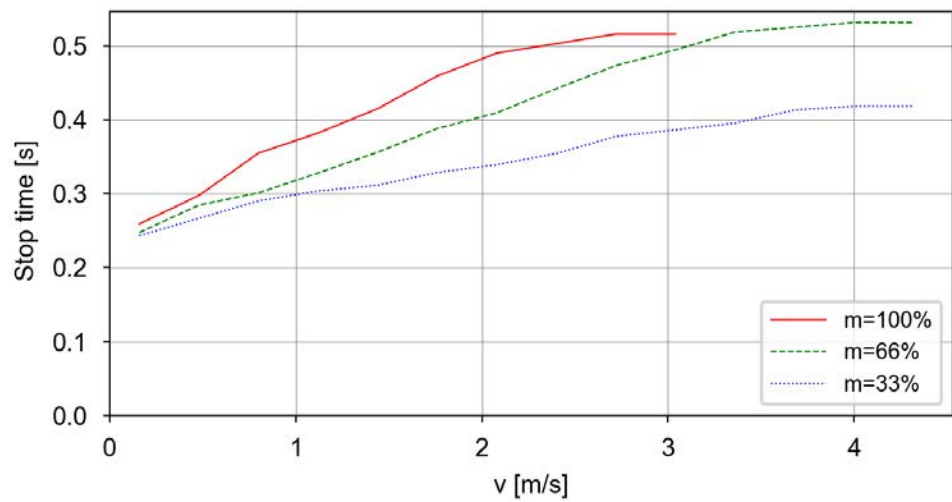
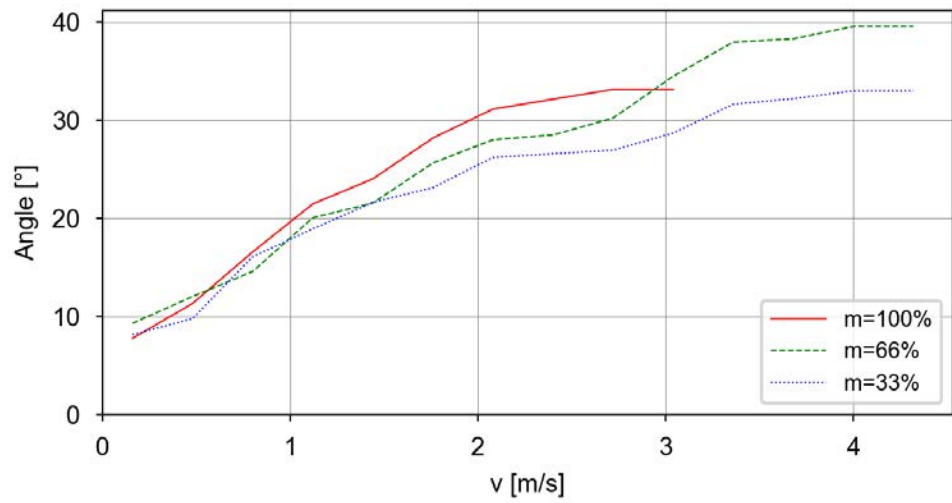

Continues on next page

Category 1, Axis 1, Extension zone 2, stopping distance and stopping time

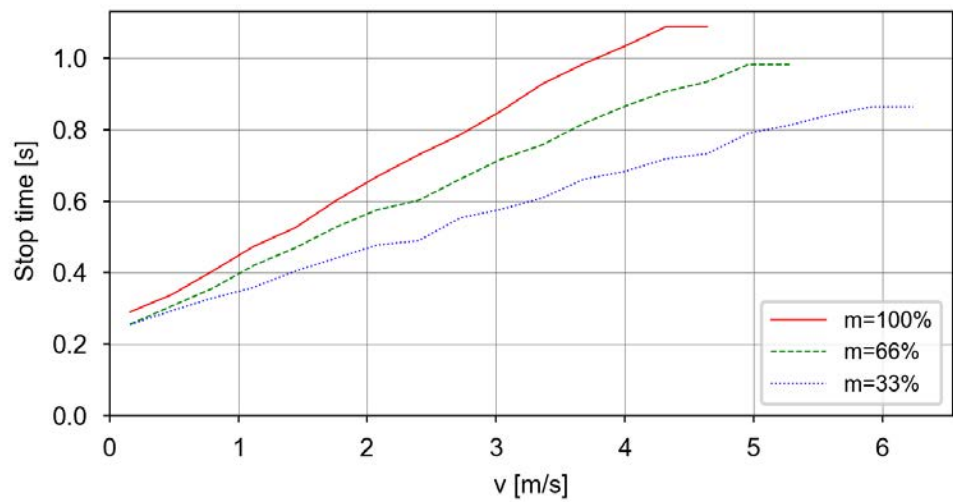
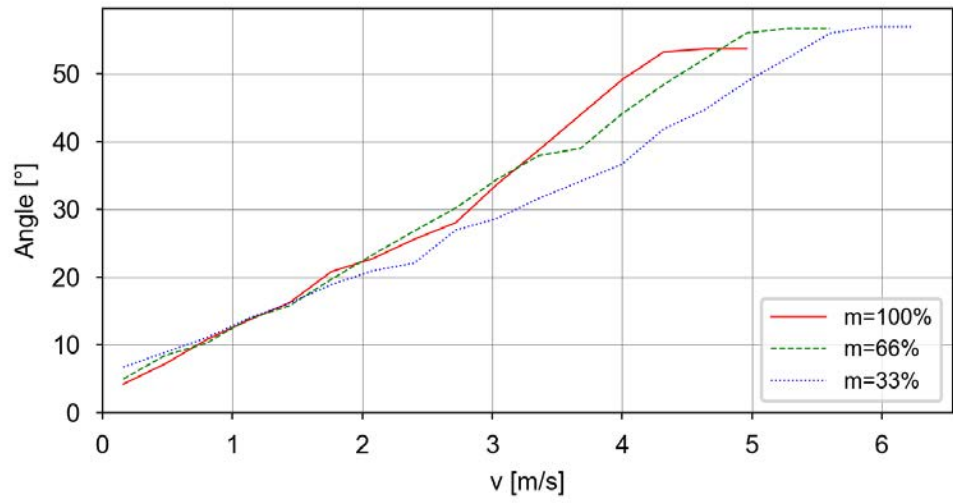

Continues on next page

## 2 Technical data for IRB 6710

### 2.10.4 IRB 6710-200/2.95

Continued

#### Category 1, Axis 2, Extension zone 0, stopping distance and stopping time

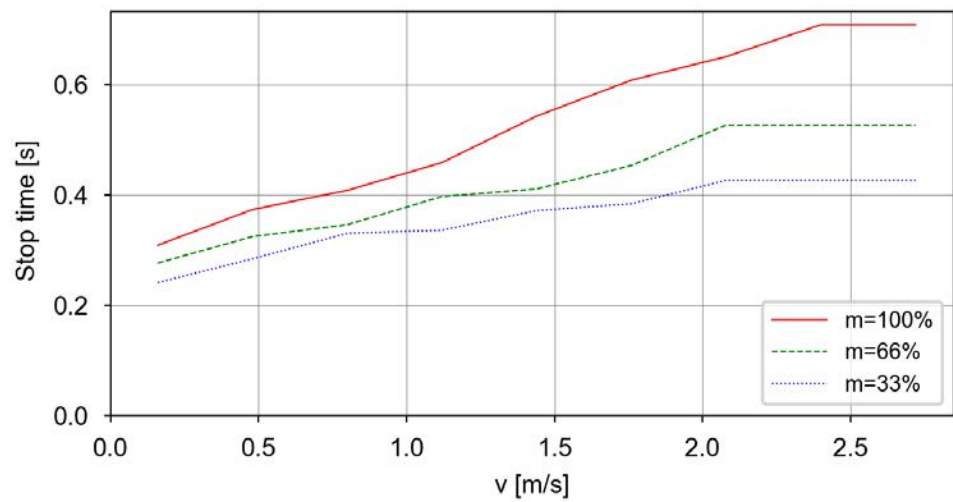
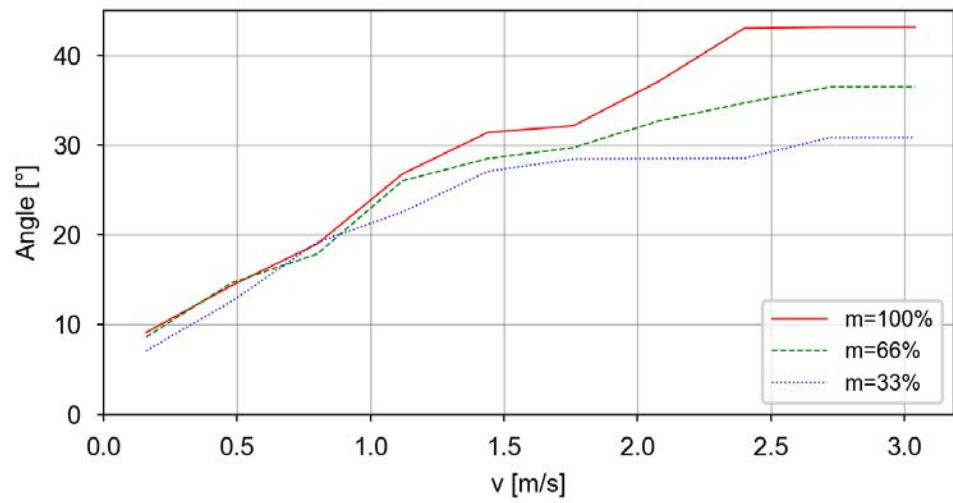

Continues on next page

Category 1, Axis 2, Extension zone 1, stopping distance and stopping time

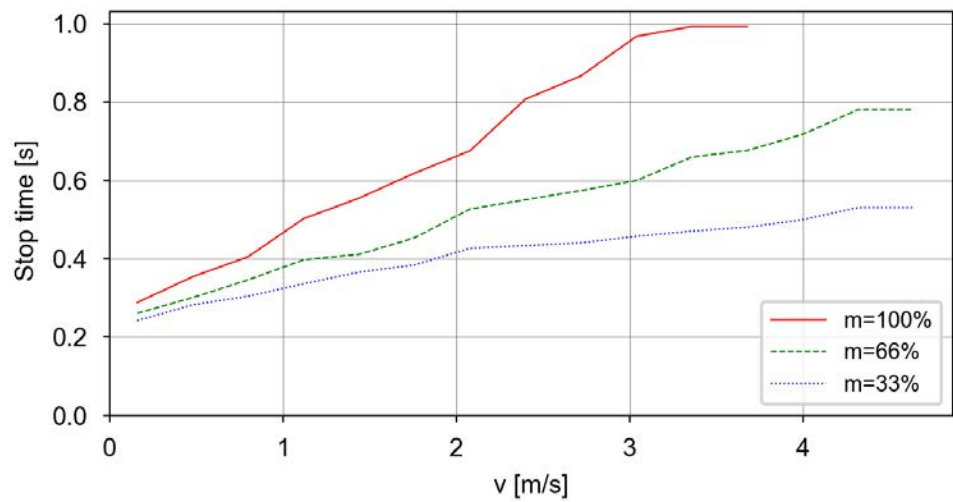
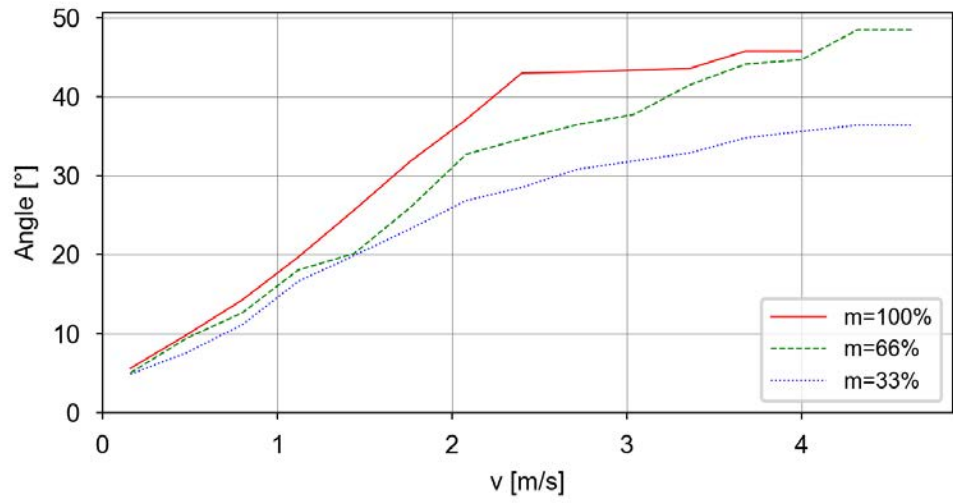

Continues on next page

## 2 Technical data for IRB 6710

### 2.10.4 IRB 6710-200/2.95

Continued

#### Category 1, Axis 2, Extension zone 2, stopping distance and stopping time

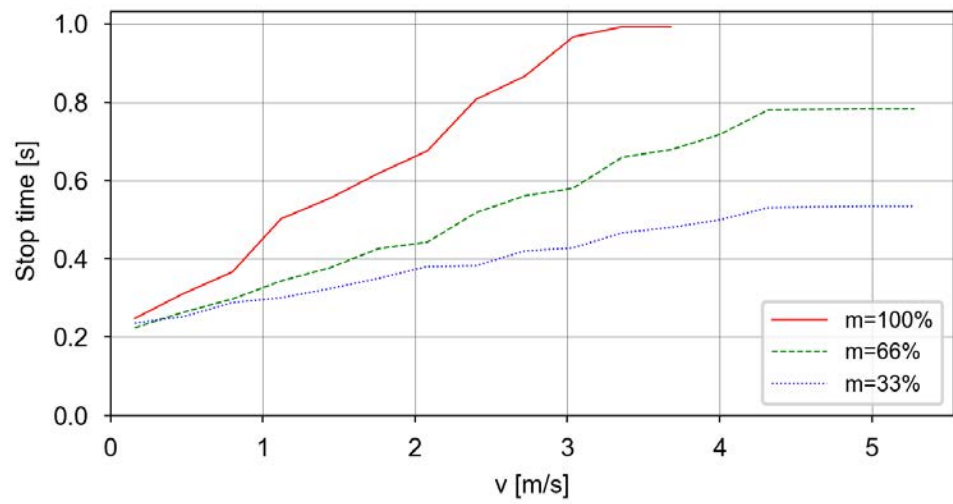
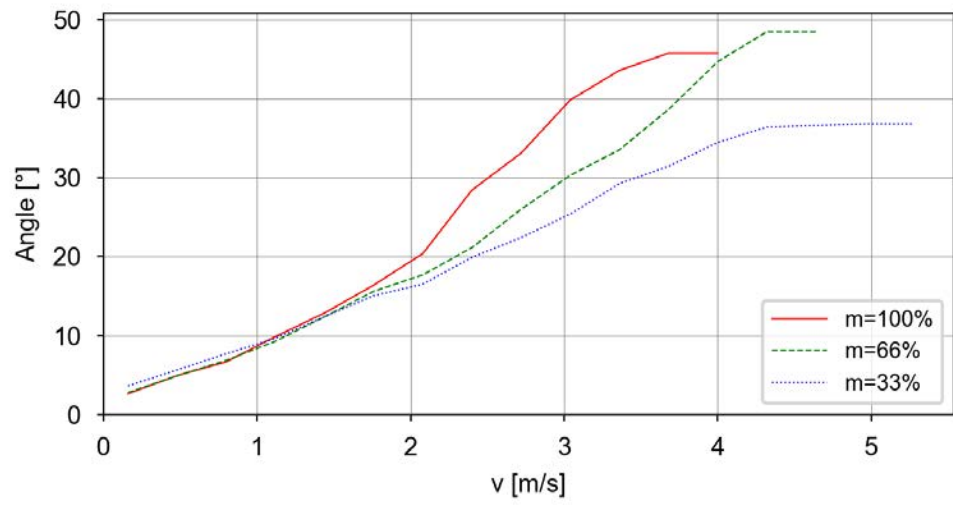

Continues on next page

Category 1, Axis 3, Extension zone 0, stopping distance and stopping time

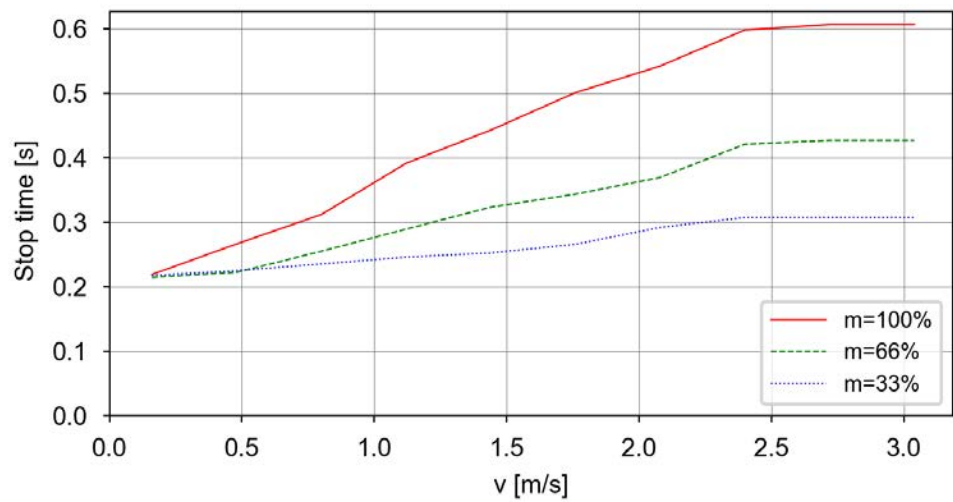
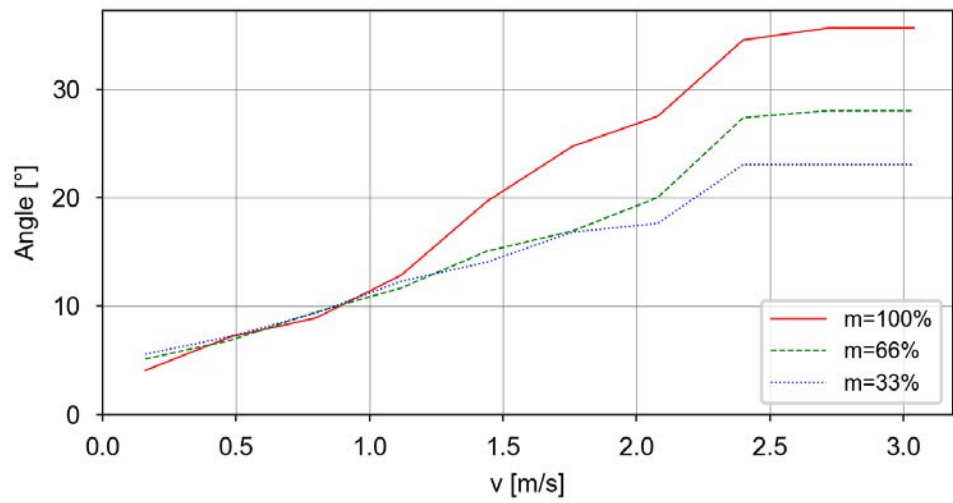

## 2 Technical data for IRB 6710

### 2.10.5 IRB 6710-175/2.65 LID

#### 2.10.5 IRB 6710-175/2.65 LID

##### Used tooldata

```
PERS tooldata P100:= [ TRUE, [[0, 0, 0], [1, 0, 0 ,0]], [175, [0,
0, 300], [1, 0, 0, 0], 2.6, 2.6, 2.6]];
PERS tooldata P66:= [ TRUE, [[0, 0, 0], [1, 0, 0 ,0]], [117, [0,
0, 200], [1, 0, 0, 0], 1.2, 1.2, 1.2]];
PERS tooldata P33:= [ TRUE, [[0, 0, 0], [1, 0, 0 ,0]], [58, [0, 0,
100], [1, 0, 0, 0], 0.29, 0.29, 0.29]];
```

##### Category 0

The following table describes the stopping distance and time for category 0 stop.

Axis	Distance	Stop time
1	32.8°	0.58 s
2	27.7°	0.41 s
3	22.1°	0.28 s

##### Category 1, extension zones

For definitions of the zones, see [Extension zones on page 89](#).

The zone border is the mounting interface location for axis 2 and axis 3.

##### Axis 1

Zone border	Axis 2	Axis 3
z0-z1	-42°	42°
z1-z2	6°	-6°

##### Axis 2

Zone border	Axis 2	Axis 3
z0-z1	48°	30°
z1-z2	85°	-30°

##### Axis 3

Only one zone exists.

*Continues on next page*

Category 1, Axis 1, Extension zone 0, stopping distance and stopping time

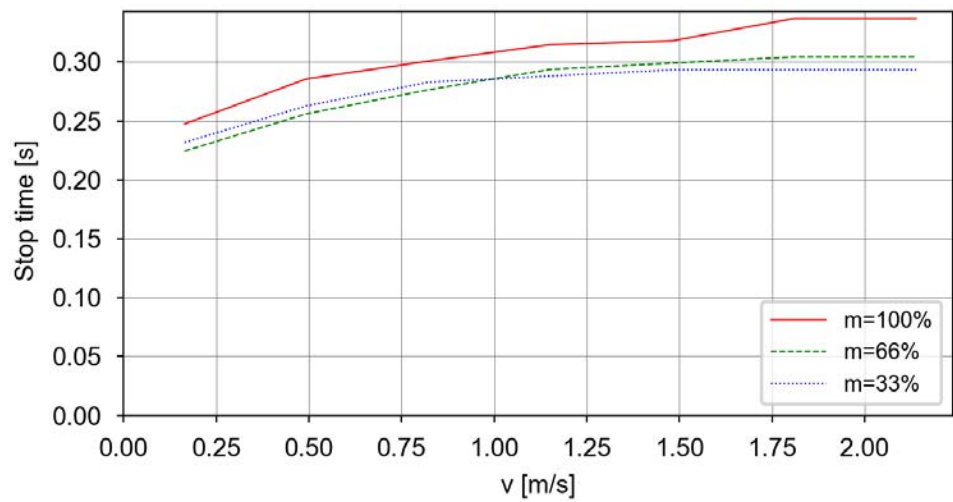
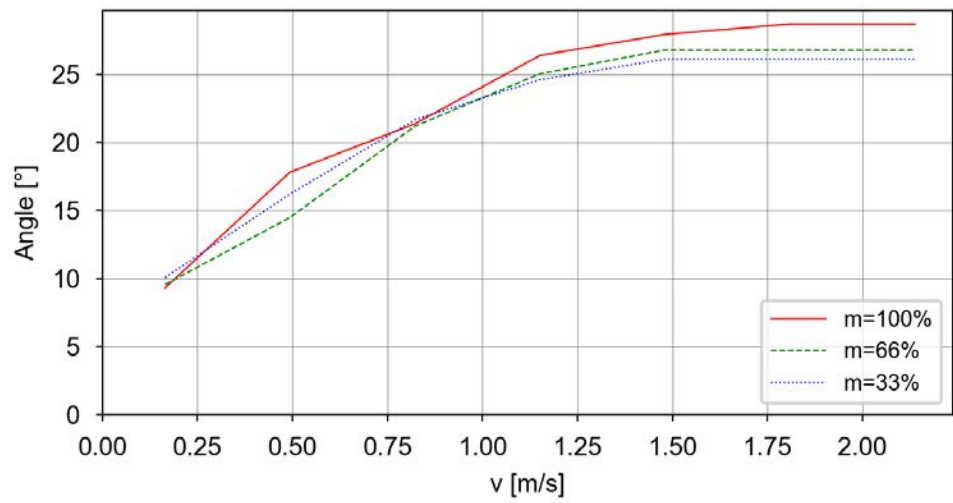

Continues on next page

## 2 Technical data for IRB 6710

### 2.10.5 IRB 6710-175/2.65 LID

Continued

#### Category 1, Axis 1, Extension zone 1, stopping distance and stopping time

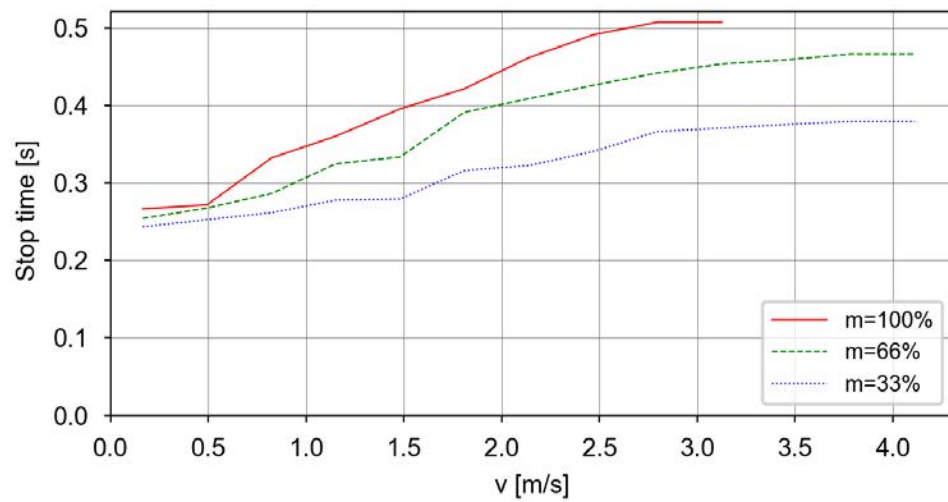
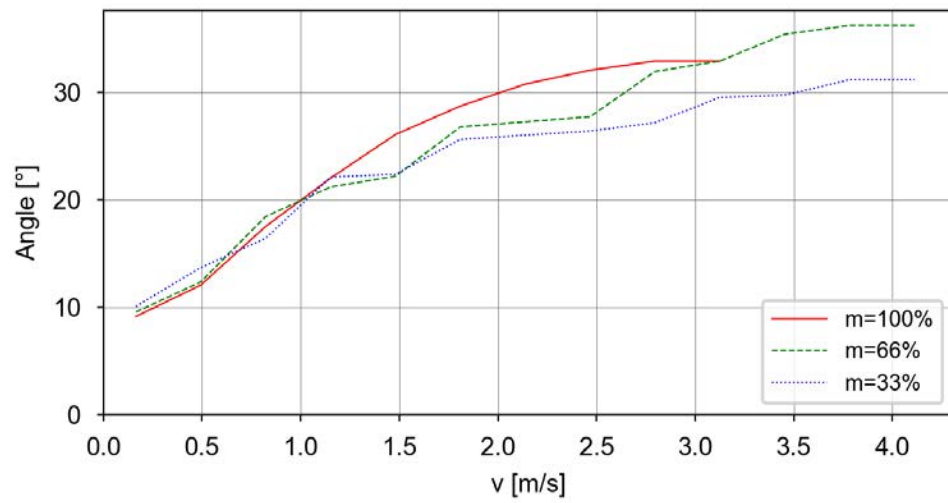

Continues on next page

Category 1, Axis 1, Extension zone 2, stopping distance and stopping time

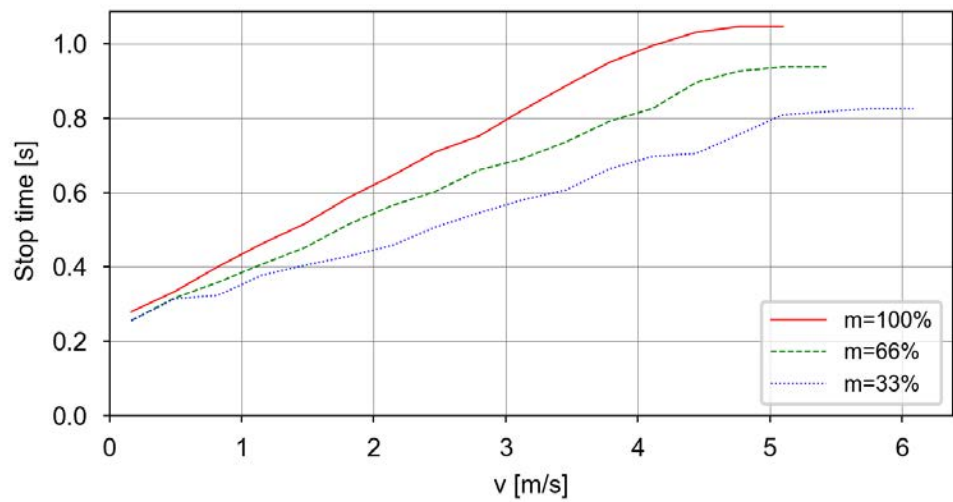
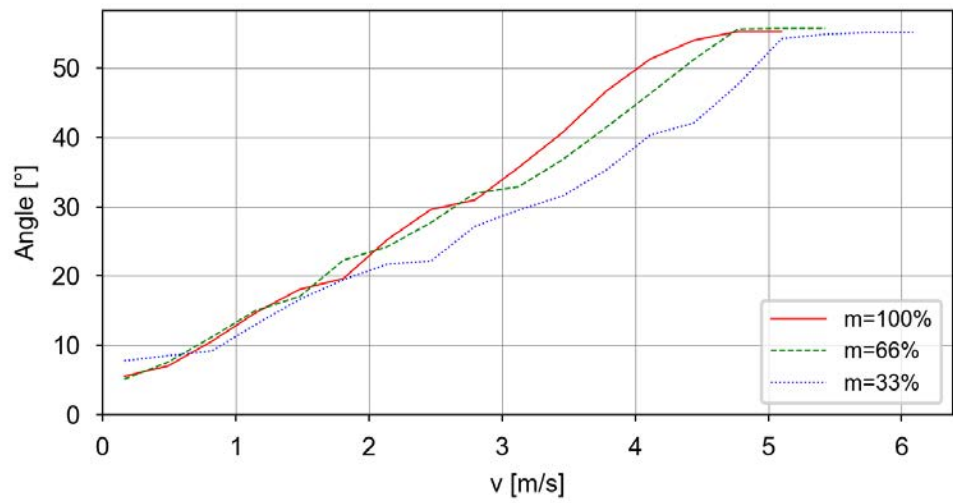

Continues on next page

## 2 Technical data for IRB 6710

### 2.10.5 IRB 6710-175/2.65 LID

Continued

#### Category 1, Axis 2, Extension zone 0, stopping distance and stopping time

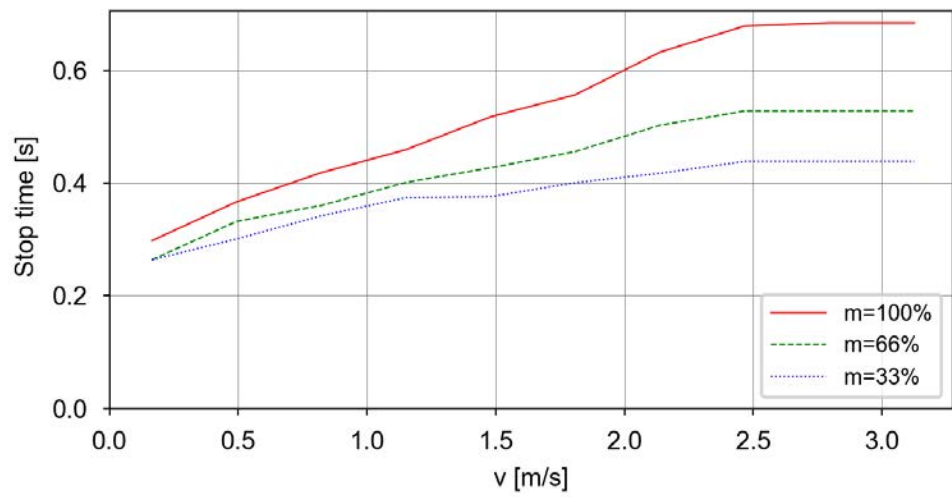
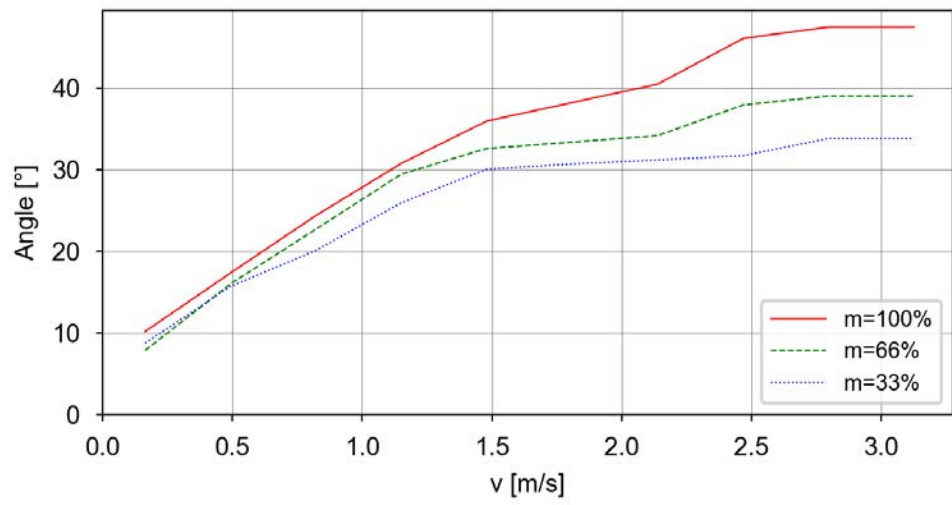

Continues on next page

Category 1, Axis 2, Extension zone 1, stopping distance and stopping time

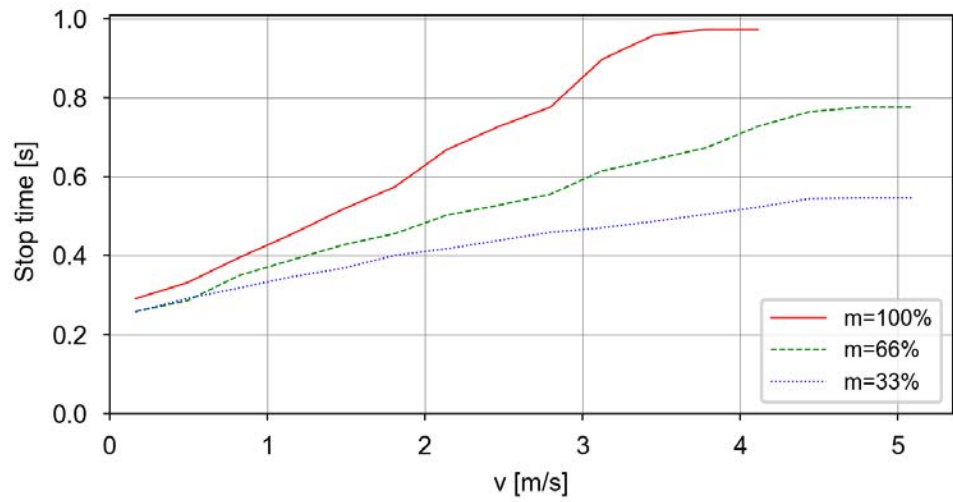
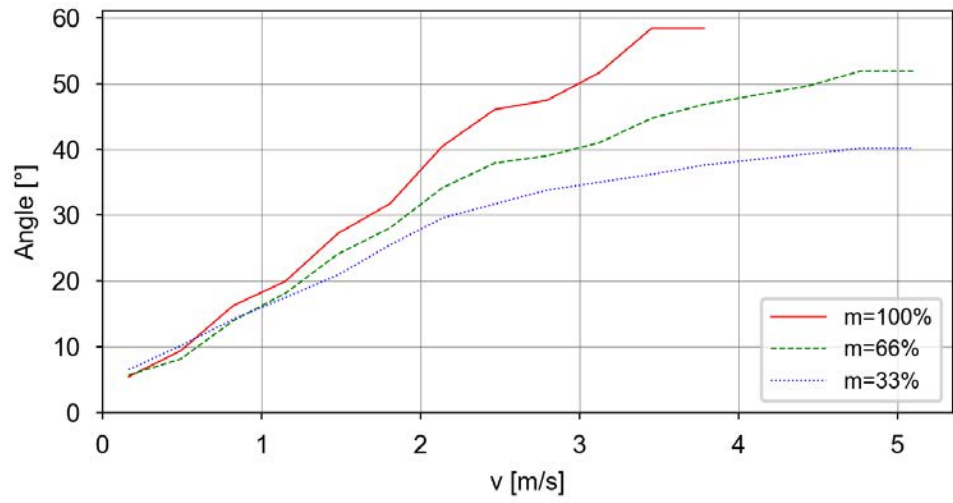

Continues on next page

## 2 Technical data for IRB 6710

### 2.10.5 IRB 6710-175/2.65 LID

Continued

#### Category 1, Axis 2, Extension zone 2, stopping distance and stopping time

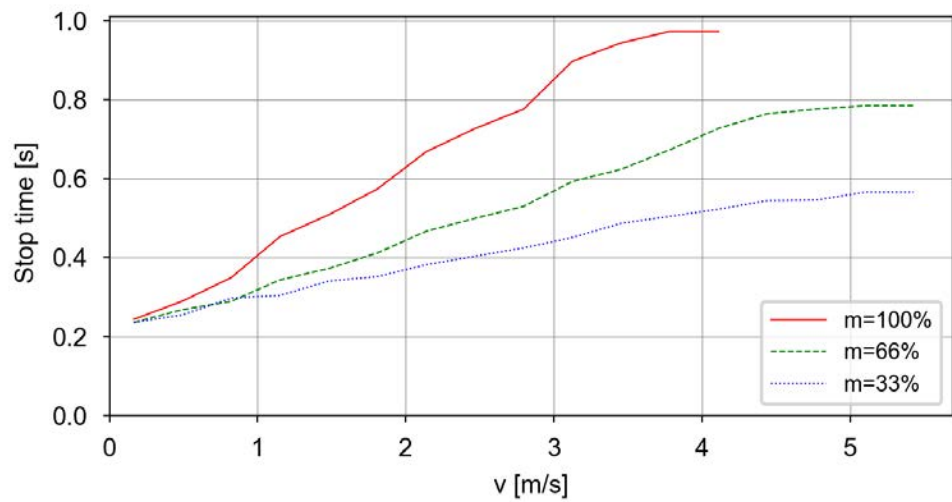
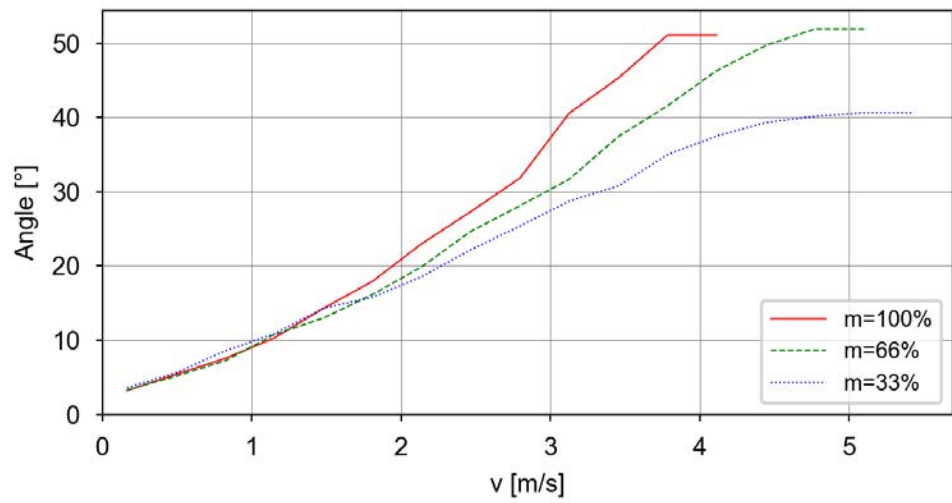

Continues on next page

Category 1, Axis 3, Extension zone 0, stopping distance and stopping time

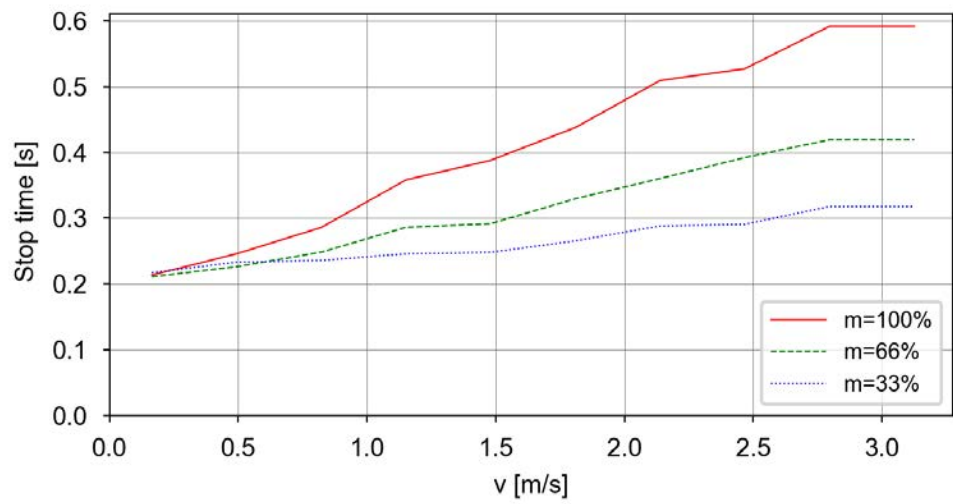
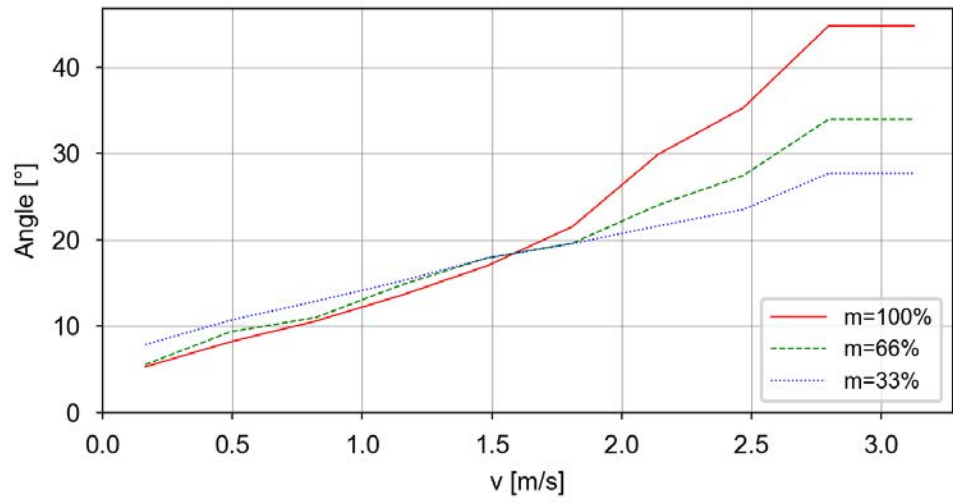

## 2 Technical data for IRB 6710

### 2.10.6 IRB 6710-175/2.95 LID

#### 2.10.6 IRB 6710-175/2.95 LID

##### Used tooldata

```
PERS tooldata P100:= [ TRUE, [[0, 0, 0], [1, 0, 0 ,0]], [175, [0,
0, 300], [1, 0, 0, 0], 2.6, 2.6, 2.6]];
PERS tooldata P66:= [ TRUE, [[0, 0, 0], [1, 0, 0 ,0]], [117, [0,
0, 200], [1, 0, 0, 0], 1.2, 1.2, 1.2]];
PERS tooldata P33:= [ TRUE, [[0, 0, 0], [1, 0, 0 ,0]], [58, [0, 0,
100], [1, 0, 0, 0], 0.29, 0.29, 0.29]];
```

##### Category 0

The following table describes the stopping distance and time for category 0 stop.

Axis	Distance	Stop time
1	33.0°	0.56 s
2	26.5°	0.43 s
3	18.3°	0.28 s

##### Category 1, extension zones

For definitions of the zones, see [Extension zones on page 89](#).

The zone border is the mounting interface location for axis 2 and axis 3.

##### Axis 1

Zone border	Axis 2	Axis 3
z0-z1	-42°	42°
z1-z2	6°	-6°

##### Axis 2

Zone border	Axis 2	Axis 3
z0-z1	48°	30°
z1-z2	85°	-30°

##### Axis 3

Only one zone exists.

*Continues on next page*

Category 1, Axis 1, Extension zone 0, stopping distance and stopping time

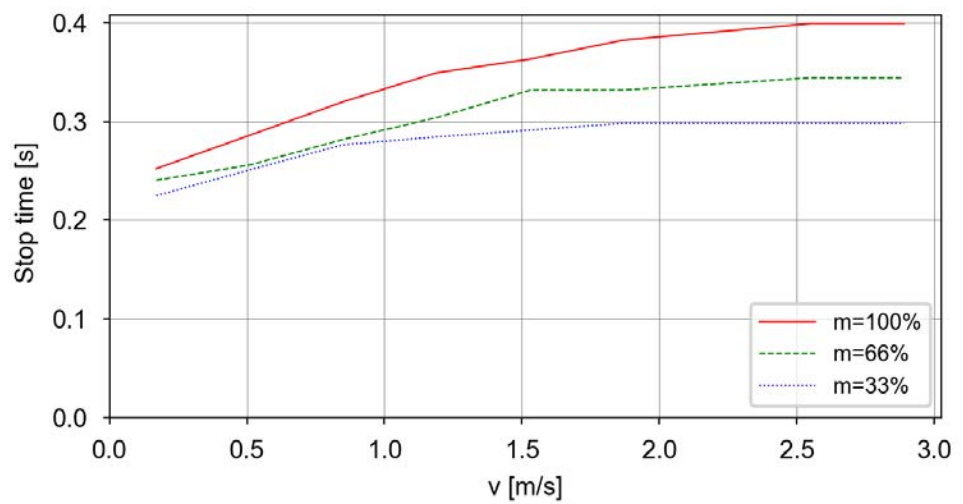
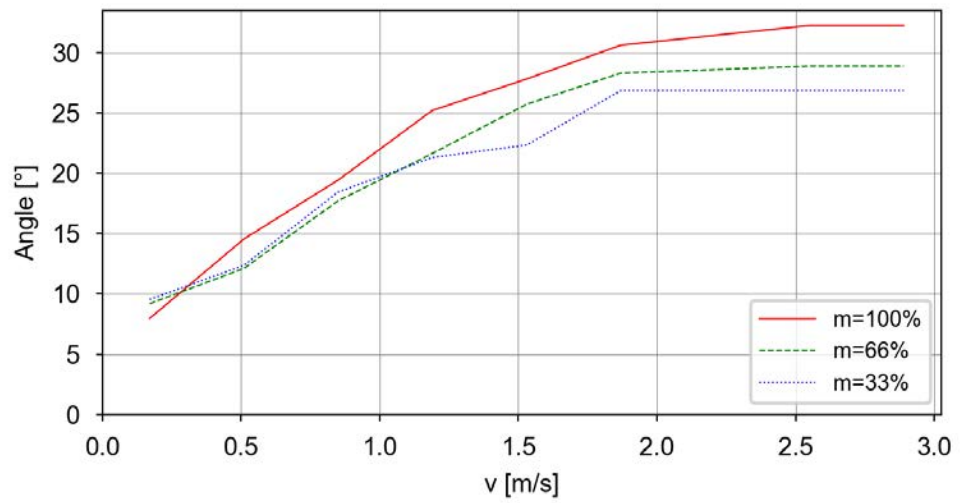

Continues on next page

## 2 Technical data for IRB 6710

### 2.10.6 IRB 6710-175/2.95 LID

Continued

#### Category 1, Axis 1, Extension zone 1, stopping distance and stopping time

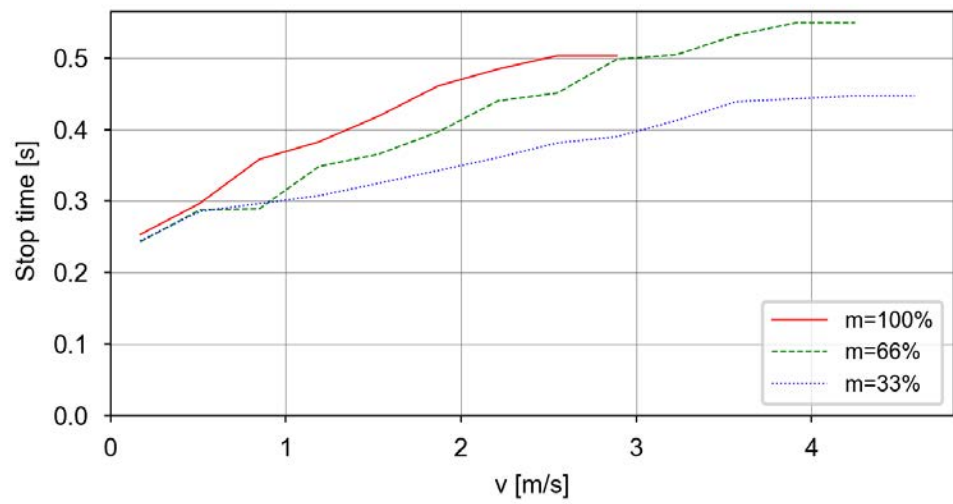
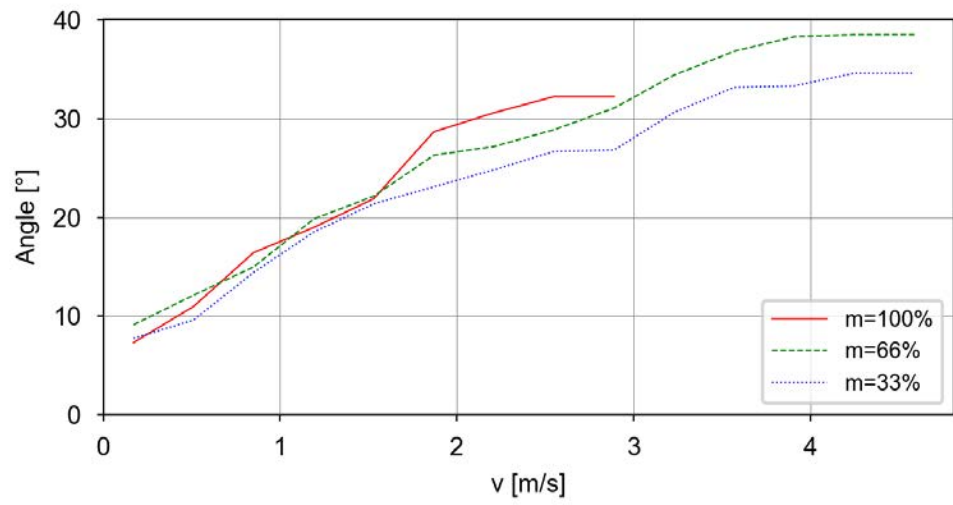

Continues on next page

Category 1, Axis 1, Extension zone 2, stopping distance and stopping time

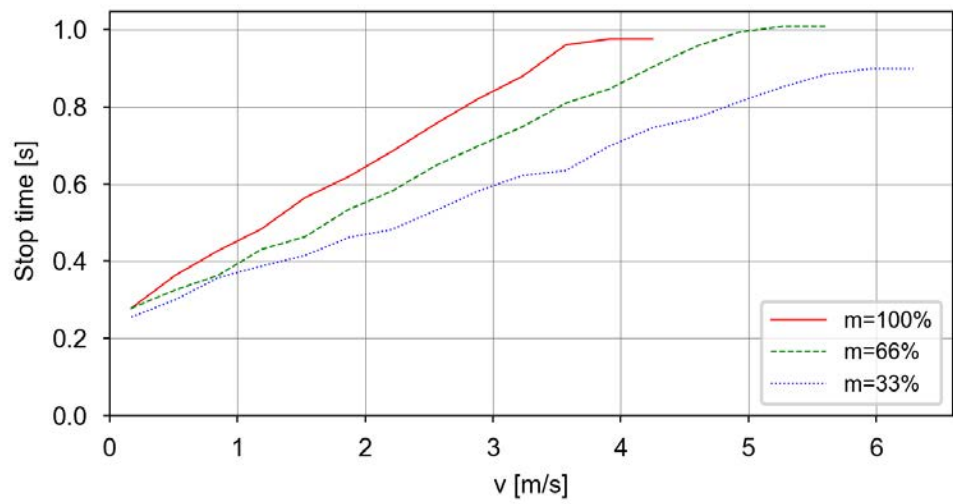
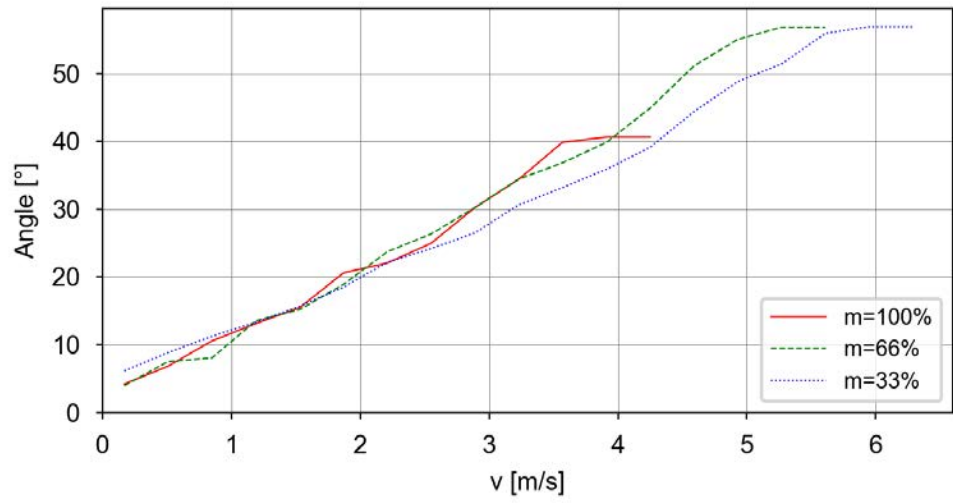

Continues on next page

## 2 Technical data for IRB 6710

### 2.10.6 IRB 6710-175/2.95 LID

Continued

#### Category 1, Axis 2, Extension zone 0, stopping distance and stopping time

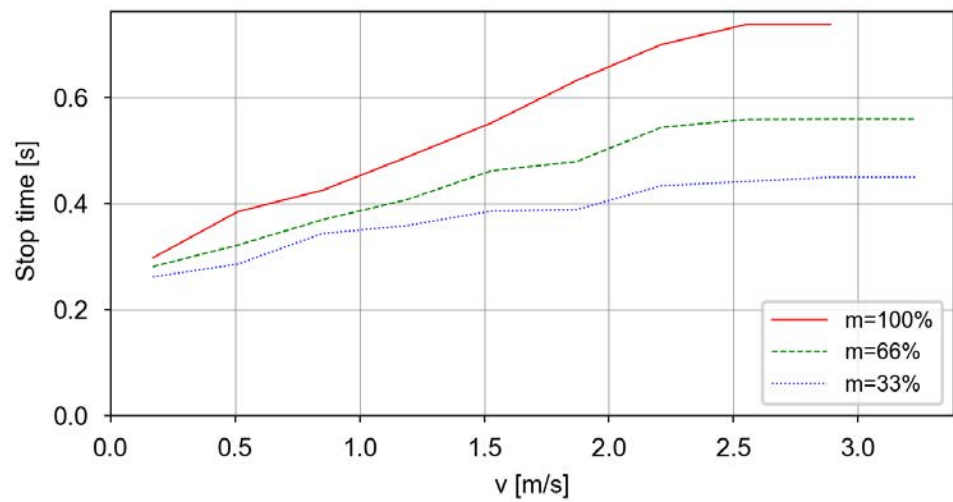
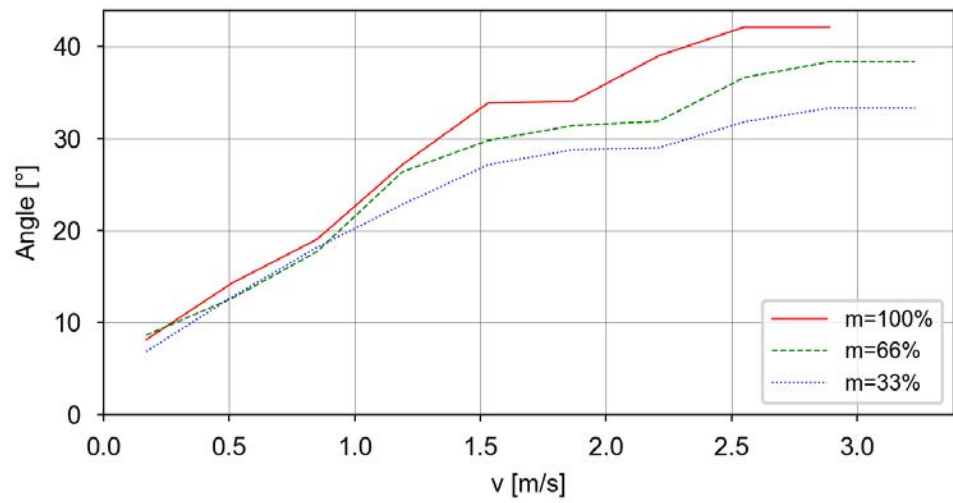

Continues on next page

Category 1, Axis 2, Extension zone 1, stopping distance and stopping time

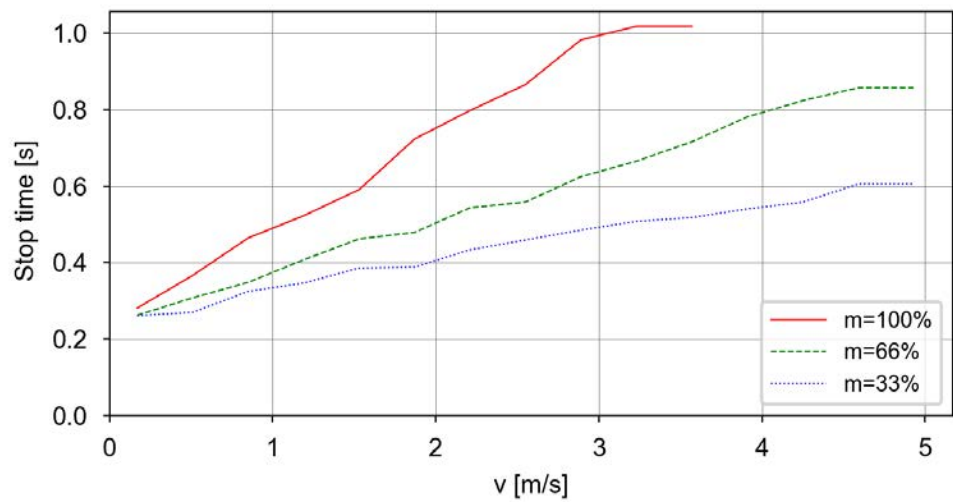
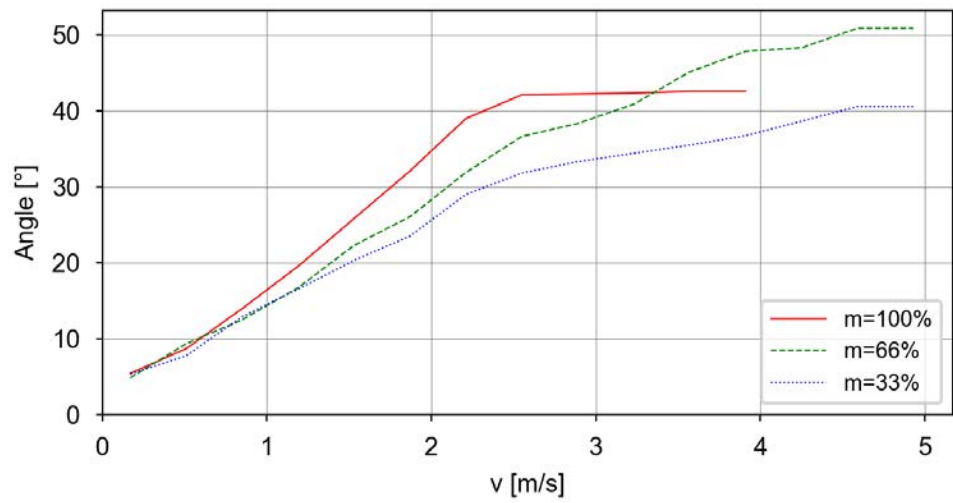

Continues on next page

## 2 Technical data for IRB 6710

### 2.10.6 IRB 6710-175/2.95 LID

Continued

#### Category 1, Axis 2, Extension zone 2, stopping distance and stopping time

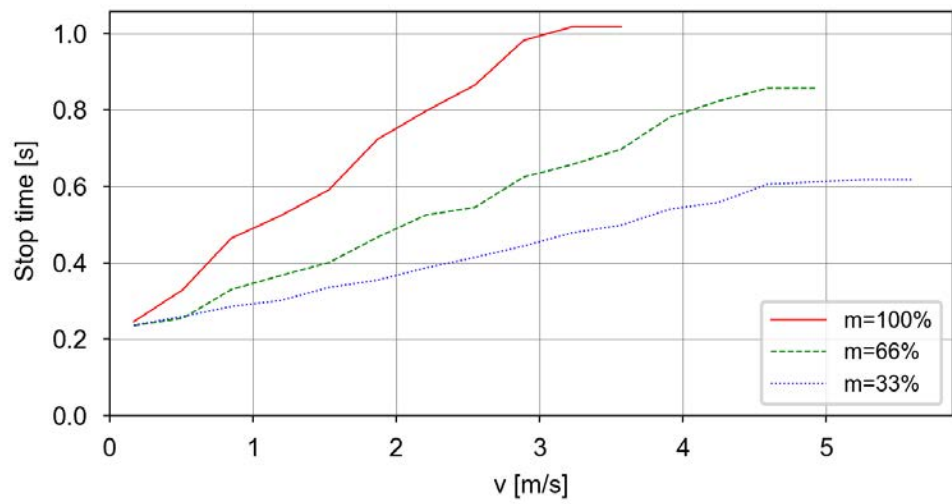
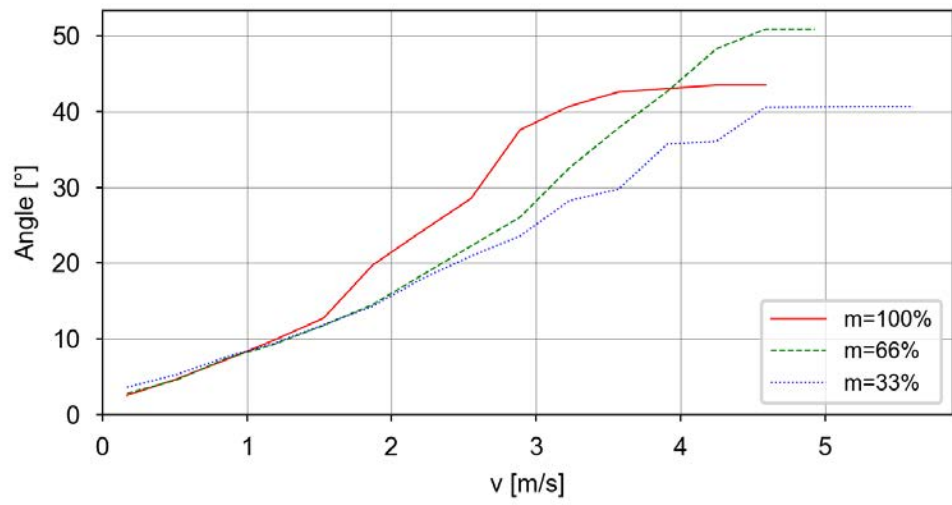

Continues on next page

Category 1, Axis 3, Extension zone 0, stopping distance and stopping time

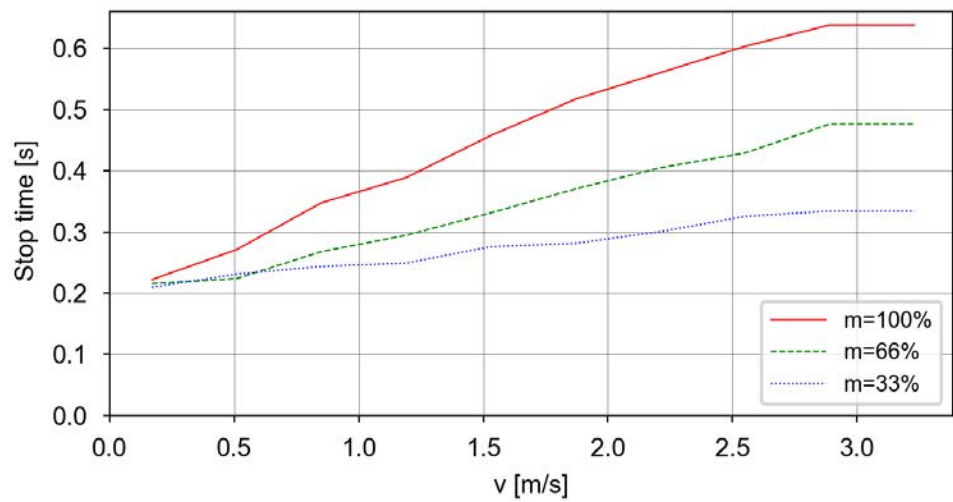
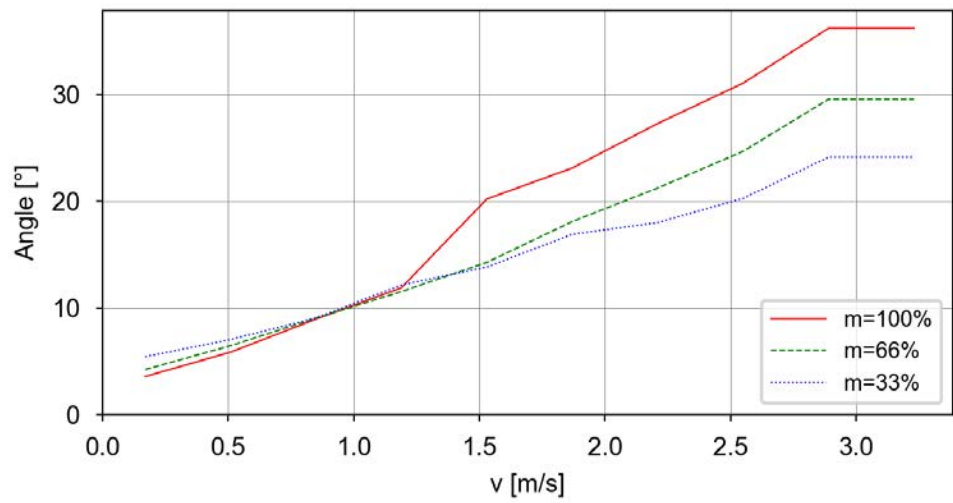

**This page is intentionally left blank**

## 3 Specification of variants and options

### 3.1 Introduction to variants and options

---

#### General

The different variants and options for the IRB 6710 are described in the following sections. The same option numbers are used here as in the specification form.

The variants and options related to the robot controller are described in the product specification for the controller.

### 3 Specification of variants and options

#### 3.2 Manipulator

#### 3.2 Manipulator

##### Variants

Option number	IRB	Handling capacity (kg)	Reach (m)	Remark
3300-330	6710	210 kg	2.65 m	
3300-331	6710	200 kg	2.95 m	
3300-332 <sup>i</sup>	6710	175 kg	2.65 m	LID (LeanID)
3300-333 <sup>i</sup>	6710	175 kg	2.95 m	LID (LeanID)

<sup>i</sup> The options 3300-332 and 3300-333 require option DressPack axis 3-6 [3326-x]

##### Color options

For our robots, Graphite White is the standard default color, option 209-202. Colors according to the RAL color system are available.



xx2300000238

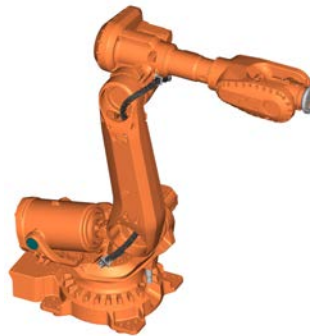

xx2300000239

Option	Color	RAL code <sup>i</sup>
209-202	ABB Graphite White std Standard color with protection option 3350-670 Base 67	RAL 7035
209-1	ABB orange standard Standard color with protection option 3352-10 Foundry Plus2 67	NCS 2070-Y60R
209-2	ABB white standard	RAL 9003
209 <sup>ii</sup>	RAL code should be specified (ABB non-standard colors)	

<sup>i</sup> The colors can differ depending on supplier and the material on which the paint is applied.

<sup>ii</sup> Only for robots with protection type *Base 67*.



##### Note

The colors stated in the table above are valid for manipulators. The accessories and spare parts are normally available in the standard color.

The orange color is recommended for foundry applications or other extra tough environments where there is a risk of color changes over time. This is not affecting the function, only the visual impression.

*Continues on next page*



**Note**

The delivery time for painted spare parts is longer for non-standard colors.

**Manipulator protection**

The manipulator is available with the following protection types.

Option	Description	Note
3350-670	Base 67	IP67
3352-10	Foundry Plus2 67	IP67

**Base 67**

The basic design (IP67) is well prepared for normal or tough environment. This includes electrical design following the IP67 standard, and stainless steel screw used for all add-on parts after painting.

**Foundry Plus2 67**

For the extra tough environment, for example foundry industries, the option *Foundry Plus2 67* is recommended as protection type. It adds extra cable protection, extra sealings, protection plugs in unused holes, added rust preventive, and special paint/surface treatment, compared to protection type *Base 67*.

The below picture shows additional parts when choosing *Foundry Plus2 67*.

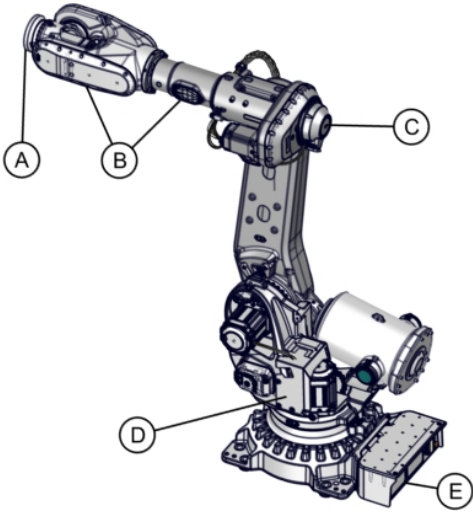
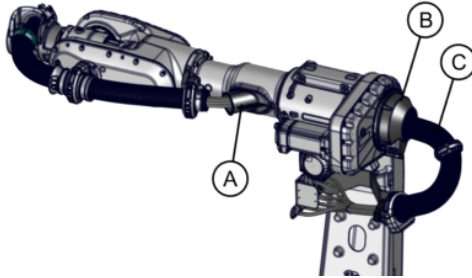
Additional parts for manipulator	Additional parts for DressPack
 <p>xx2300001726</p> <ul style="list-style-type: none"> <li>A Turning disc with Nickel-phosphorus coating</li> <li>B Rubber gasket</li> <li>C Protective cover</li> <li>D Protective cover</li> <li>E Sheet metal in stainless steel</li> </ul>	 <p>xx2300001727</p> <ul style="list-style-type: none"> <li>A Cable inlet</li> <li>B Protective cover</li> <li>C Cable protection</li> </ul>

**Requirements**

The option *Foundry Plus2* requires option *Upper arm cover* [3316-1].

*Continues on next page*

### 3 Specification of variants and options

#### 3.2 Manipulator

*Continued*

#### Foundry cable guard

Option	Description
3315-1	Foundry cable guard

The manipulator can be equipped with additional cable guards for extra tough environmental conditions, for example, metals spits or frequent weld spatter. These additional covers will prolong cable lifetime and simplify service/maintenance as the robot is kept more clean under the covers.

The option *Foundry Cable Guard* is recommended for *Foundry Plus2*.

#### Requirements

The option *Foundry Cable Guard* requires option *Upper arm cover* [3316-1].

#### Foundry cable guards for manipulator cable harness

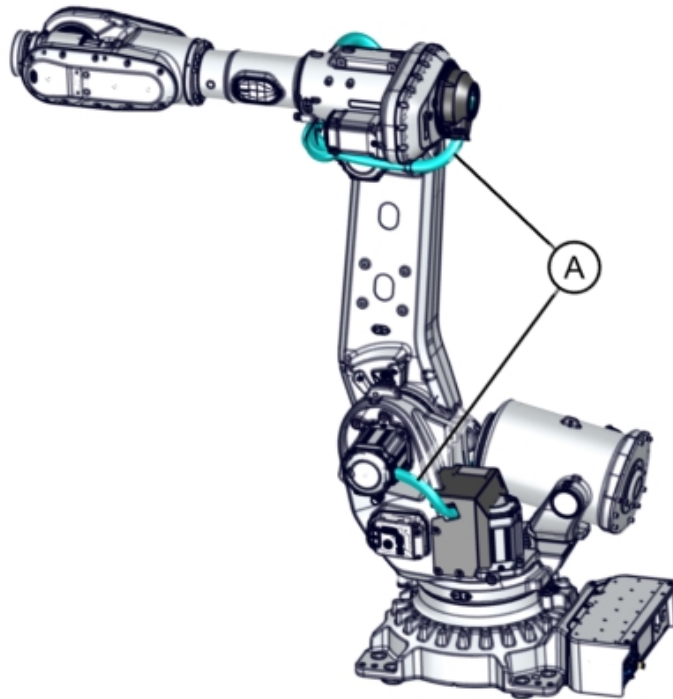

xx2300001724

A	Foundry cable guard for manipulator cable harness
---	---

*Continues on next page*

#### Foundry cable guard for DressPack

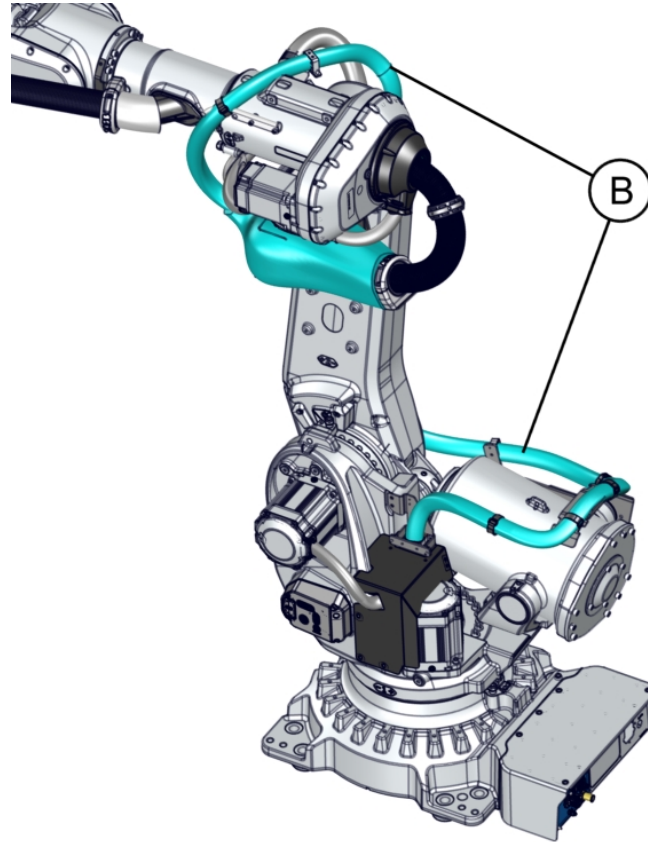

xx2300001725

<b>B</b>	<b>Foundry cable guard for DressPack</b>
----------	--

#### Upper arm cover

Option	Description	Image
3316-1	<p><b>Upper arm cover</b></p> <p>The manipulator can be equipped with additional upper arm covers for environmental conditions, where you want to further seal off the upper arm in wet or dirty conditions. These additional covers will prolong the lifetime of the cables, and simplify service/maintenance as the robot is kept more clean under the covers.</p>	<p style="text-align: right; font-size: small;">xx2500000237</p>

#### Requirements

This option is mandatory to order with the option *Foundry Plus2* [3352-10].

This option is mandatory to order with the option *Foundry Cable Guard* [3315-1].

This option is mandatory to order with the option *DressPack axis 3-6* [3326-x].

*Continues on next page*

### 3 Specification of variants and options

#### 3.2 Manipulator

*Continued*

##### Forklift device

The manipulator can be delivered with forklift devices, allowing a forklift to be used when moving the manipulator.

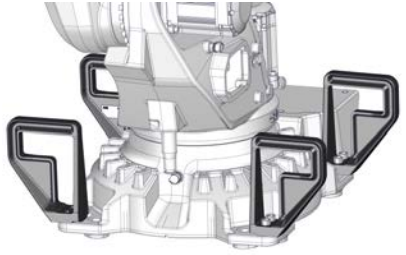
Option	Description	
3318-1	Forklift device on base Forklift pockets placed on the base gives a low lifting point.	 xx2300001244

##### Motor cooling

To be used to avoid overheating of motors and gears in applications with intensive motion (high average speed and/or high average torque and/or short wait time) of the axes on the lower arm.

Option	Description
3320-1	Cooling fan axis 1
3321-1	Cooling fan axis 2

The cooling fan has protection class IP54.

To determine the need of cooling fans on the motors, use the add-in **Mechanical Analysis** in RobotStudio. For more information, contact your local ABB office.

##### Limitations

Cannot be combined with protection type Foundry Plus2 67.

Cannot be combined with track motion.

##### Resolver connection 7th axis

Option	Description
3322-1	On base
3322-2	In servo DressPack This option is required for the option 3325-x DressPack base-axis 3 including servo.

Option 3222-2 In servo DressPack adds a connection point for the 7th axis servo feedback on the frame of the robot to be used in servo DressPack.

##### Limited working range

Option	Description
3323-1	Axis 1 adjustable 15°

The manipulator can be equipped with adjustable mechanical stops. This is to mechanically limit the working range on axis 1. The mechanical stops are delivered

*Continues on next page*

alongside the robot (not installed). The stops can be placed in steps according to the option.

For detailed information see [Installing movable mechanical stops on axis 1 \(option 3323-1\) on page 61](#).

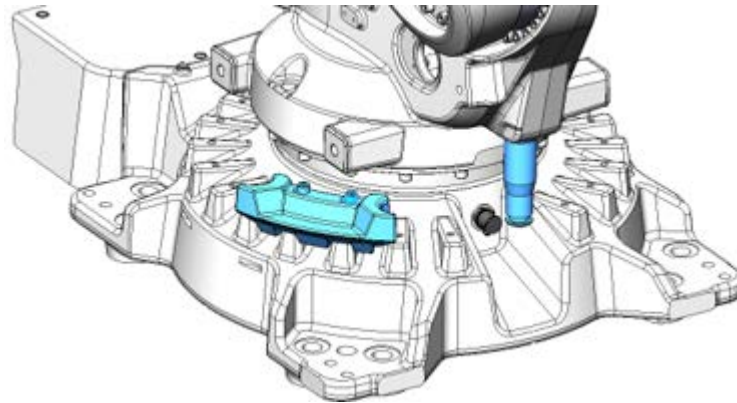

xx2100002595



**Tip**

An alternative to mechanical stops is to use safe supervision of the working range limitations. This requires the option *SafeMove Standard+*. See the product specification for the respective robot controller.

#### Extended working range

Option	Description	
3324-1	Axis 1 to $\pm 220^\circ$	The option extends the working range on axis 1 from $\pm 170^\circ$ to $\pm 220^\circ$ .



**CAUTION**

The option *Extended work range* enables an extension of the working range for axis 1, through a software configuration. With this option installed, the working range can exceed the range limited by the mechanical stop on axis 1. The working range shall be limited through the option *SafeMove*.

A risk analysis must be done to ensure that no risks remain when using option *Extended work range*, to limit the working range, and before removing the mechanical stops.

For information about the option *SafeMove*, see *Application manual - Functional safety and SafeMove*.

If the mechanical stop is removed, then the manipulator should have a marking for this, for example, a label. If the robot is delivered with the option *Extended work range*, then such a label is included on delivery.

#### Requirements

This option requires the option *SafeMove* [3043-x].

### 3 Specification of variants and options

#### 3.3 Floor cables

#### 3.3 Floor cables



#### Note

To comply with the EMC directive, the total cable length (including cables for the motor connection box) must not exceed 30 m between:

Controller and robot (IRB)

Controller and motor & gear units (MU/GU) or track motion (IRT)

Controller and positioner (IRP)

#### Manipulator cable - Length

Option	Description
3200-2	7 m
3200-3	15 m
3200-4	22 m
3200-5	30 m

#### Bending radius for static floor cables

The minimum bending radius is 10 times the cable diameter for static floor cables.

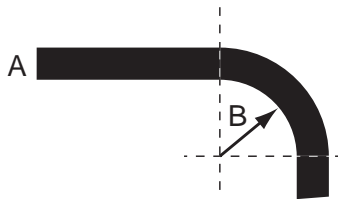

xx1600002016

A	Diameter
B	Diameter x10

## 3.4 Application

### 3.4.1 Overview of DressPack options

#### General

The DressPack is built in sections with connection interfaces in between. The cables for customer connection are partly integrated in the robot and the connectors are placed at axis 6, axis 3, and at the base. Depending on what signals are required, there are different variants available (Parallel, EtherNet, CC link, EtherCAT) with corresponding connections at axis 6, axis 3, and at the base interface.

Parallel	PROC1 (1/2" Hose for compressed air) & CP/CS Hose (1/2") for compressed air is included in all DressPack variants. There is one inlet at the base (M22x1.5), one outlet at axis 3 (M22x1.5), and a free end at axis 6.
EtherNet	PROC1, CP/CS, EtherNet & FE (functional earth)
CC link	PROC1, CP/CS, EtherNet & FE (functional earth)
EtherCAT	PROC1, CP/CS, EtherNet & FE (functional earth)

#### Requirements

Upper arm DressPack requires lower arm DressPack.

LID manipulator variants can only use LID DressPack.

LID manipulator variants require both lower and upper arm DressPack.

### 3 Specification of variants and options

#### 3.4.2 DressPack for material handling

#### 3.4.2 DressPack for material handling

##### Connection interfaces

Below is an overview showing the DressPack connection points. For detailed information see *Circuit diagram - DressPack IRB 67xx / IRB 67xxS*, listed in [References on page 7](#).

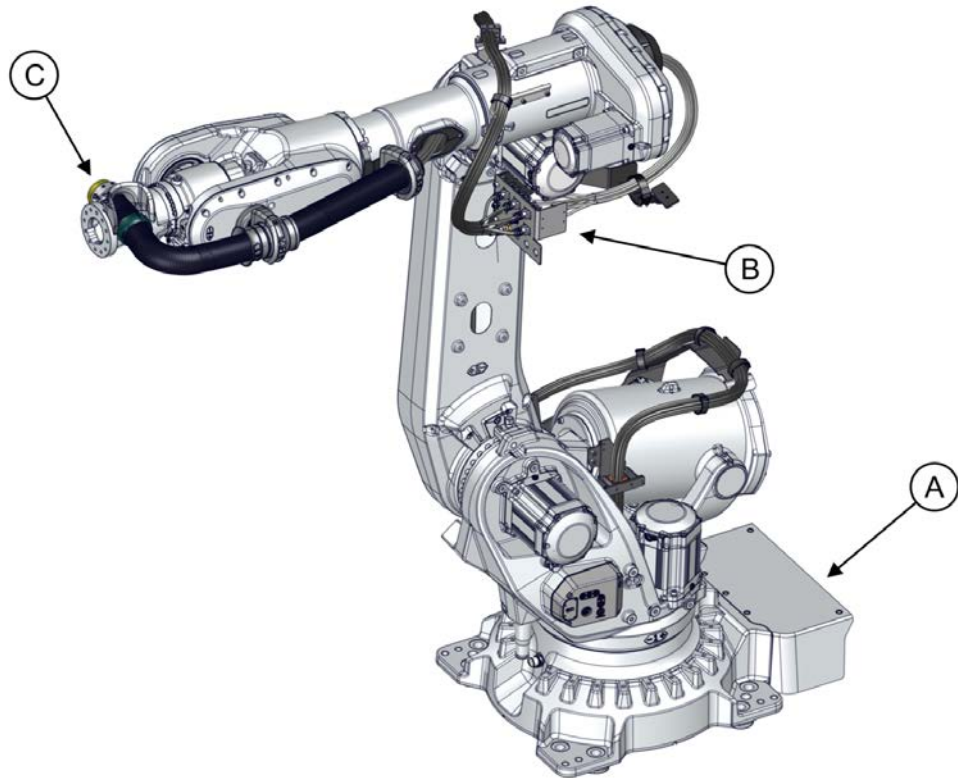

xx2300001353

A	Base
B	Axis 3
C	Axis 6

##### Manipulator DressPack MH

Base to axis 3	Axis 3 to axis 6
3325-11 MH Parallel	3326-11 MH3 Parallel
	3326-30 MH LID empty conduit
	3326-31 MH LID Parallel
3325-13 MH Ethernet	3326-13 MH3 EtherNet
	3326-30 MH LID empty conduit
	3326-33 MH LID EtherNet

*Continues on next page*

### 3 Specification of variants and options

#### 3.4.2 DressPack for material handling

*Continued*

Base to axis 3	Axis 3 to axis 6
3325-14 MH CC-Link	3326-14 MH3 CC-Link
	3326-30 MH LID empty conduit
	3326-34 MH LID CC-Link
3325-15 MH EtherCat	3326-15 MH3 EtherCat
	3326-30 MH LID empty conduit
	3326-35 MH LID EtherCat

#### DressPack MH base to axis 3

Option	Description	Note	Connectors
3325-11	MH Parallel	Lower arm MH	Customer power (CP), customer signal (CS), and PROC1
3325-13	MH EtherNet	Lower arm MH Includes parallel signals. Supports ProfiNet, EtherNet/IP.	Customer power (CP), customer signal (CS), ETHERNET, PROC1, and functional earth (FE)
3325-14	MH CC-Link	Lower arm MH Includes parallel signals.	Customer power (CP), customer signal (CS), ETHERNET, PROC1, and functional earth (FE)
3325-15	MH EtherCat	Lower arm MH Includes parallel signals.	Customer power (CP), customer signal (CS), ETHERNET, PROC1, and functional earth (FE)

#### Connection plate at base for DressPack MH

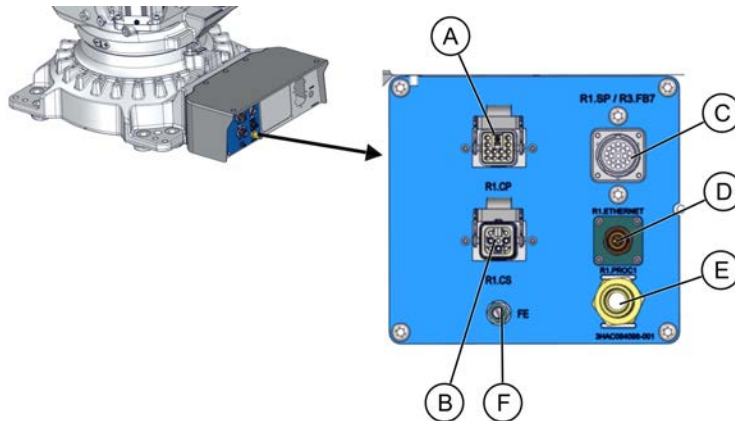

xx2300000241

A	Customer power (CP)
B	Customer signal (CS)
C	Resolver connection
D	ETHERNET
E	PROC1 (1/2" hose)
F	Functional earth (FE)

*Continues on next page*

### 3 Specification of variants and options

---

#### 3.4.2 DressPack for material handling

*Continued*

For corresponding parts of the tool, see [Connector kits manipulator on page 151](#).

*Continues on next page*

#### Connection plate at axis 3 for DressPack MH

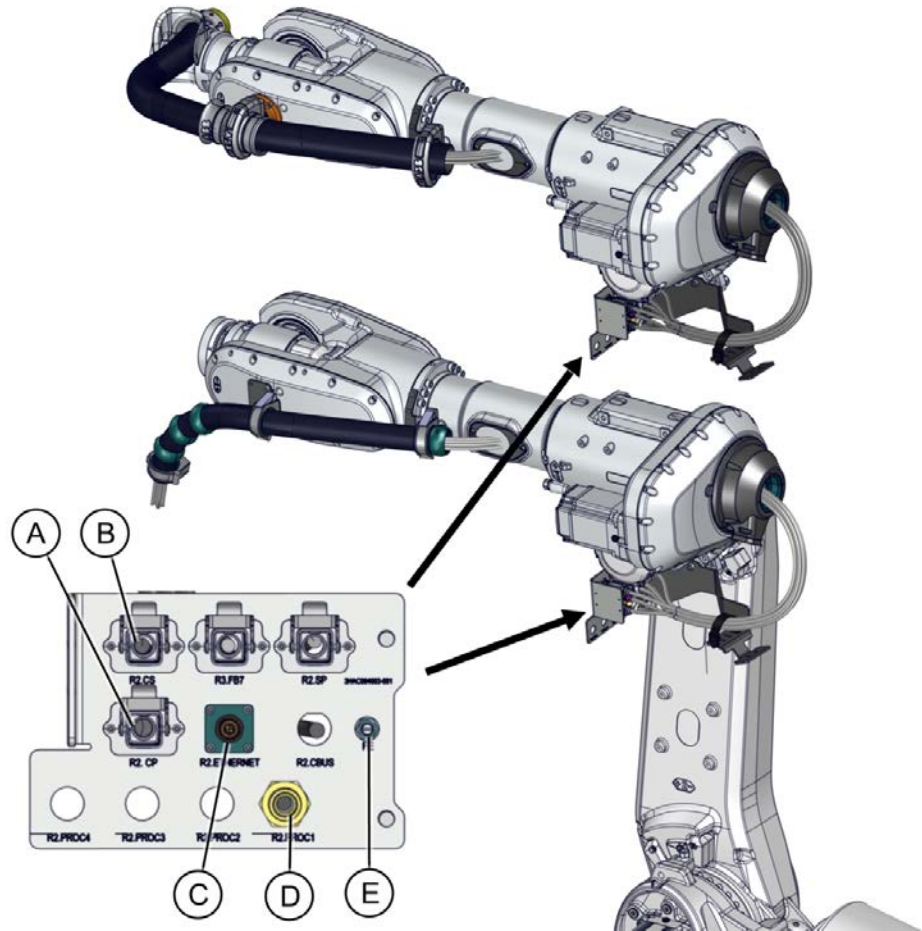

xx2300000246

A	Customer power (CP)
B	Customer signal (CS)
C	ETHERNET
D	PROC 1 (1/2" hose)
E	Functional earth (FE)

For corresponding parts of the tool, see [Connector kits manipulator on page 151](#).

#### DressPack axis 3 to axis 6

Option	Description	Note	Connectors
3326-11	MH3 Parallel	Upper arm MH3	Customer power (CP), customer signal (CS), and PROC1
3326-13	MH3 EtherNet	Upper arm MH3 Includes parallel signals. Supports ProfiNet, EtherNet/IP.	Customer power (CP), customer signal (CS), ETHERNET, PROC1, and functional earth (FE)

Continues on next page

### 3 Specification of variants and options

#### 3.4.2 DressPack for material handling

Continued

Option	Description	Note	Connectors
3326-14	MH3 CC-Link	Upper arm MH3 Includes parallel signals.	Customer power (CP), customer signal (CS), ETHERNET, PROC1, and functional earth (FE)
3326-15	MH3 EtherCat	Upper arm MH3 Includes parallel signals.	Customer power (CP), customer signal (CS), ETHERNET, PROC1, and functional earth (FE)
3326-30	MH LID Empty Conduit	LeanID	
3326-31	MH LID Parallel	LeanID MH	Customer power (CP), customer signal (CS), and PROC1
3326-33	MH LID EtherNet	LeanID MH Includes parallel signals. Supports ProfiNet, Ether- tIP.	Customer power (CP), customer signal (CS), ETHERNET, PROC1, and functional earth (FE)
3326-34	MH LID CC-Link	LeanID MH Includes parallel signals.	Customer power (CP), customer signal (CS), ETHERNET, PROC1, and functional earth (FE)
3326-35	MH LID EtherCat	LeanID MH Includes parallel signals.	Customer power (CP), customer signal (CS), ETHERNET, PROC1, and functional earth (FE)

End connectors at axis 6 for DressPack MH

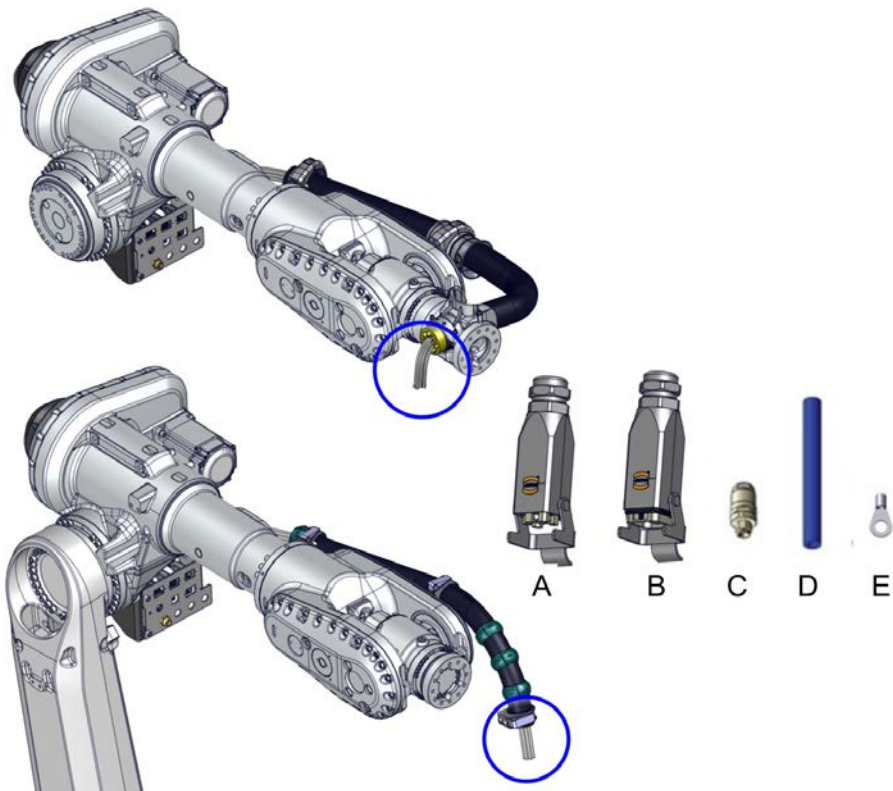

xx2300000247

Continues on next page

### 3 Specification of variants and options

#### 3.4.2 DressPack for material handling

*Continued*

A	Customer power (CP)
B	Customer signal (CS)
C	ETHERNET
D	PROC 1 (1/2" hose)
E	FE (functional earth)

MH3: Hose and cable free length, 1,000 mm

LID: Hose and cable free length, 1,000 mm

For corresponding parts of the tool, see [Connector kits manipulator on page 151](#).

#### Drilling pattern for MH3 gripping clamp

Drilling pattern for the MH3 gripping clamp is shown below.

Attachment screws M8x16 (2 pcs) are included in the delivery.

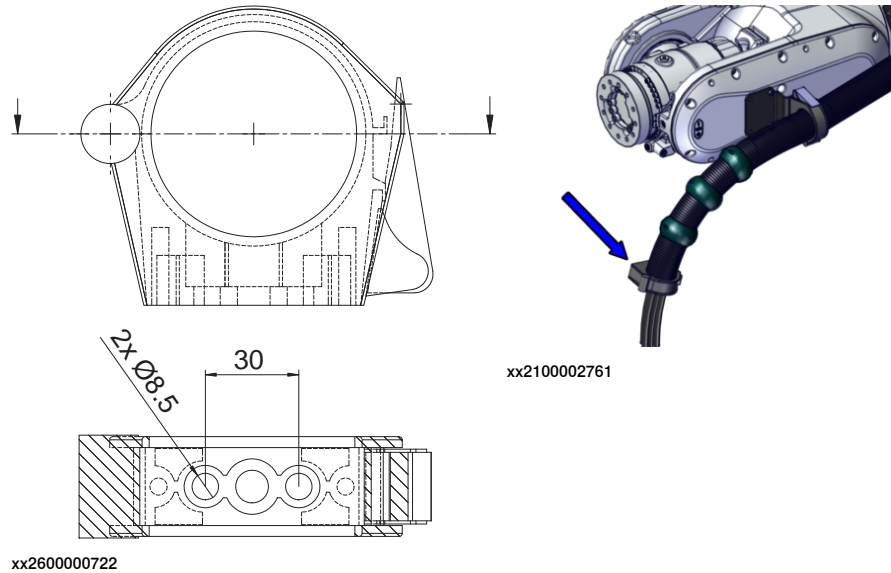

### 3 Specification of variants and options

#### 3.4.3 DressPack for spotwelding

#### 3.4.3 DressPack for spotwelding

##### Connection interfaces

Below is an overview showing the DressPack connection points. For detailed information see *Circuit diagram - DressPack IRB 67xx / IRB 67xxS*, listed in [References on page 7](#).

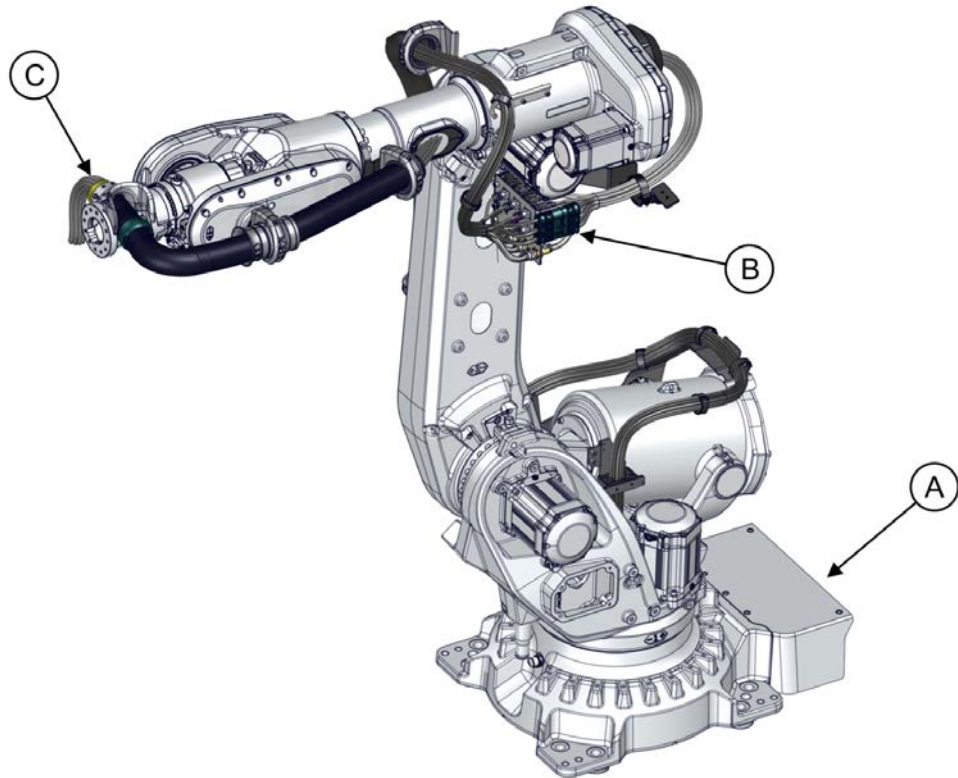

xx2300001354

A	Base
B	Axis 3
C	Axis 6

##### Manipulator DressPack SW

Base to axis 3	Axis 3 to axis 6
3325-51 SW Parallel	3326-51 SW LID Parallel
	3326-50 SW LID Empty Conduit
3325-61 SW Parallel-Servo	3326-61 SW LID Parallel-Servo
	3326-50 SW LID Empty Conduit
3325-63 SW Ethernet-Servo	3326-63 SW LID EtherNet-Servo
	3326-50 SW LID Empty Conduit
3325-64 SW LID CC-Link-Servo	3326-64 SW LID CC Link-Servo
	3326-50 SW LID Empty Conduit

*Continues on next page*

### 3 Specification of variants and options

#### 3.4.3 DressPack for spotwelding

*Continued*

Base to axis 3	Axis 3 to axis 6
3325-65 SW LID EtherCat-Servo	3326-65 SW LID EtherCat-Servo
	3326-50 SW LID Empty Conduit

#### DressPack SW base to axis 3

Option	Description	Note	Connectors
3325-61	SW Parallel-Servo	Lower arm SW	Customer power (CP), customer signal (CS), Servo power (SP), Servo feedback (FB)
3325-63	SW Ethernet-Servo	Lower arm SW Includes parallel signals. Supports ProfiNet, EtherCAT	Customer power (CP), customer signal (CS), Servo power (SP), Servo feedback (FB)
3325-64	SW CC Link-Servo	Lower arm SW Includes parallel signals.	Customer power (CP), customer signal (CS), Servo power (SP), Servo feedback (FB)
3325-65	SW EtherCat Link-Servo	Lower arm SW Includes parallel signals.	Customer power (CP), customer signal (CS), Servo power (SP), Servo feedback (FB)

#### Connection plate at base for DressPack SW

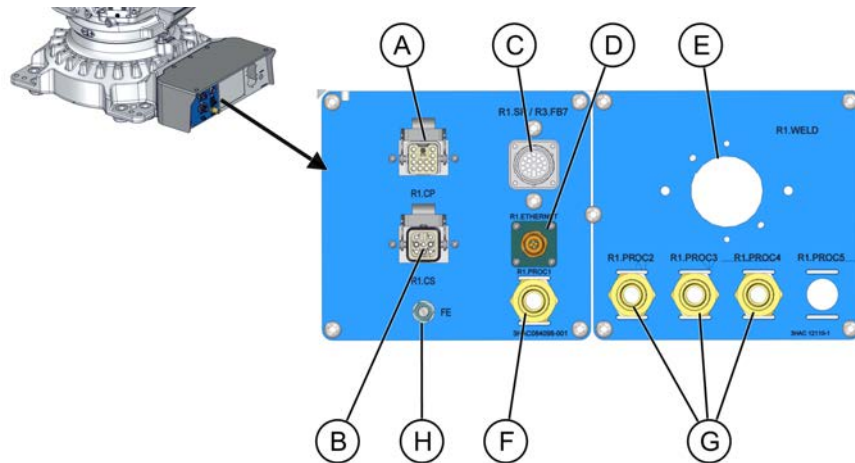

xx2300000250

A	Customer power (CP)
B	Customer signal (CS)
C	Servo Power (SP)
D	ETHERNET
E	WELD3 x 35 mm <sup>2</sup> (spot welding)
F	PROC1 (1/2" hose, M22 x 1.5, 24 degree seal)
G	PROC2-4 (spot welding 1/2", M22 x 1.5, 24 degree seal)
H	Functional earth (FE)

*Continues on next page*

### 3 Specification of variants and options

---

#### 3.4.3 DressPack for spotwelding

*Continued*

For corresponding parts of the tool, see [Connector kits manipulator on page 151](#).

*Continues on next page*

### 3 Specification of variants and options

#### 3.4.3 DressPack for spotwelding Continued

#### Connection plate at axis 3 for DressPack SW and LeanID SW

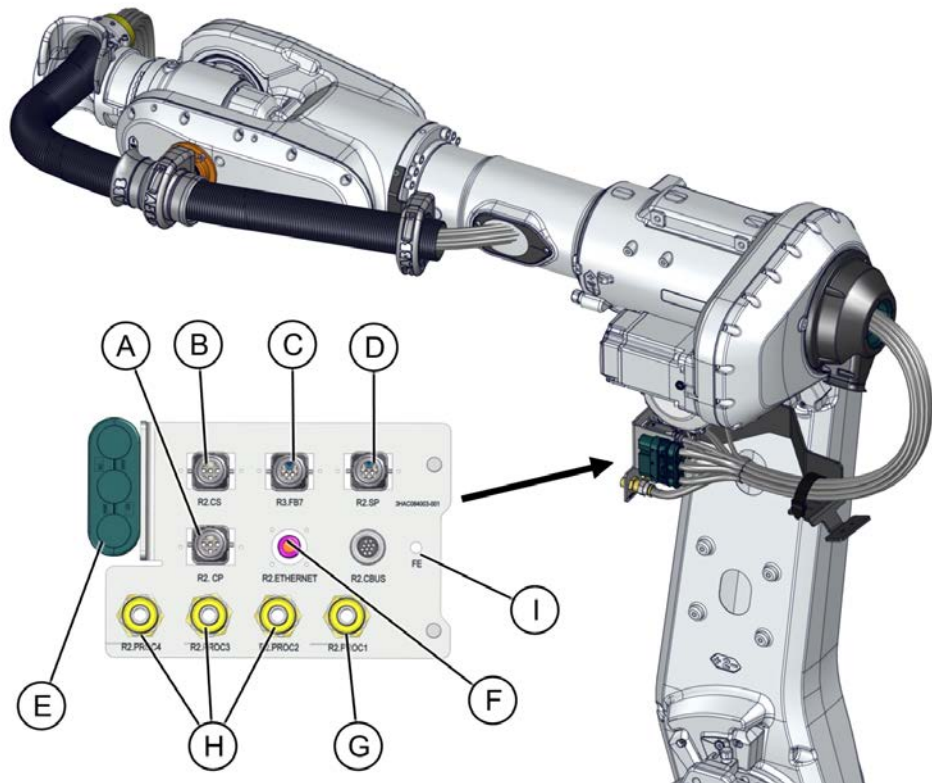

xx2300000251

A	Customer power (CP)
B	Customer signal (CS)
C	Servo feedback (FB)
D	Servo power (SP)
E	WELD3 x 25 mm <sup>2</sup> (spot welding)
F	ETHERNET
G	PROC1 (1/2" hose, M22 x 1.5, 24 degree seal)
H	PROC2-4 (spot welding 1/2", M22 x 1.5, 24 degree seal)
I	Functional earth (FE)

For corresponding parts of the tool, see [Connector kits manipulator on page 151](#).

#### DressPack axis 3 to axis 6

Option	Description	Note	Connectors
3326-50	SW LID Empty Conduit	Upper arm SW LID	
3326-61	SW LID Parallel-Servo	Upper arm SW LID	Customer power (CP), customer signal (CS)

*Continues on next page*

### 3 Specification of variants and options

#### 3.4.3 DressPack for spotwelding

Continued

Option	Description	Note	Connectors
3326-63	SW LID EtherNet-Servo	Upper arm SW LID Includes parallel signals. Supports ProfiNet, EtherNet/IP	Customer power (CP), customer signal (CS)
3326-64	SW LID CC Link-Servo	Upper arm SW LID Includes parallel signals.	Customer power (CP), customer signal (CS)
3326-65	SW LID EtherCat-Servo	Upper arm SW LID Includes parallel signals.	Customer power (CP), customer signal (CS)

End connectors at axis 6 for DressPack LeanID SW

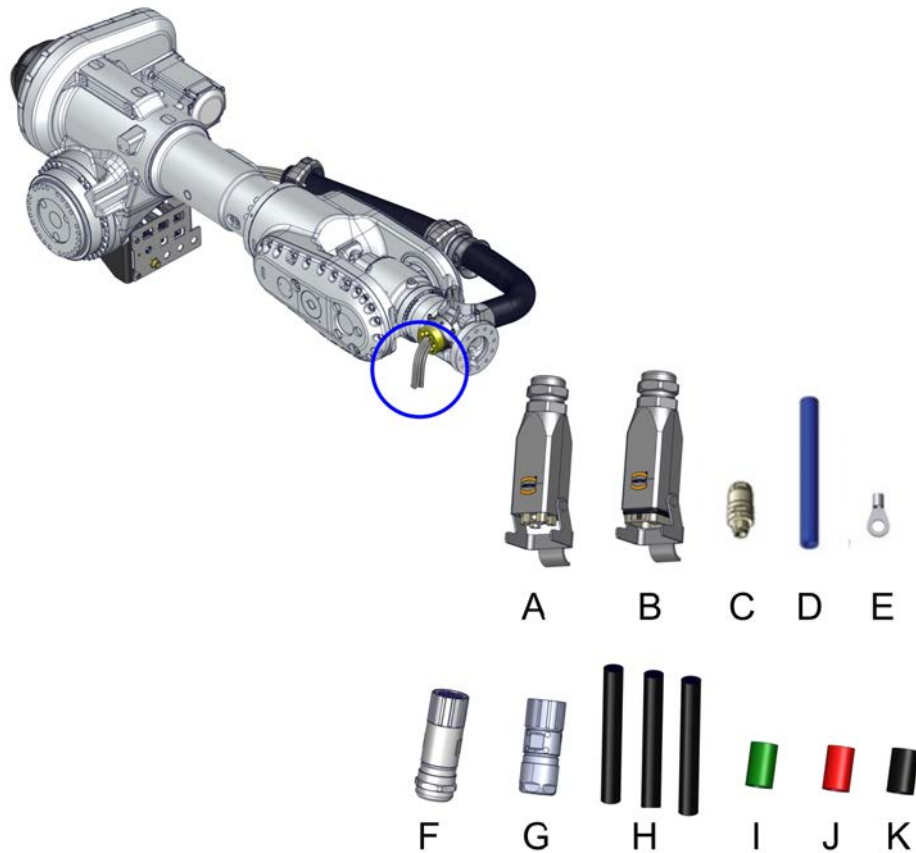

xx2400001297

A	Customer power (CP)
B	Customer signal (CS)
C	ETHERNET
D	PROC 1 (1/2" hose)
E	FE (functional earth)
F	Servo power (SP)
G	Servo feedback (FB)
H	Weld x 3
I	PROC 2 (1/2" hose)

Continues on next page

### 3 Specification of variants and options

---

#### 3.4.3 DressPack for spotwelding

*Continued*

J	PROC 3 (1/2" hose)
K	PROC 4 (1/2" hose)

For corresponding parts of the tool, see [Connector kits manipulator on page 151](#).

### 3 Specification of variants and options

#### 3.4.4 Configuration result of DressPack options

#### 3.4.4 Configuration result of DressPack options

##### DressPack options for material handling (MH)

The DressPack contents will differ depending on selected options. See table for signal content below.

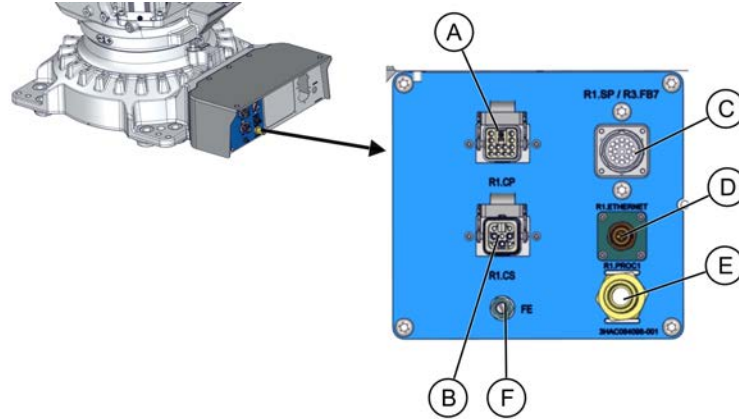

xx2300000241

A	Customer power (CP)
B	Customer signal (CS)
C	Resolver connection
D	ETHERNET
E	PROC1 (1/2" hose)
F	Functional earth (FE)

	Type	At terminals in cabinet	At connection point; base, axis 3, or axis 6	Cable/part area	Allowed capacity
A	<b>Customer Power (CP)</b>				
	Utility power	3	3	1.5 mm <sup>2</sup>	250 V AC, 10 A rms
	Protective earth	1	1	1.5 mm <sup>2</sup>	250 V AC
	Utility power	4	4	0.5 mm <sup>2</sup>	50 V DC, 1 A rms
B	<b>Customer Signal (CS)</b>				
	Signals shielded		8 (4x2)	0.24 mm <sup>2</sup>	30 V AC, 42 V DC, 1 A rms
D	<b>Customer bus (Ethernet)</b>				
	Bus signals	4	4	0.4 mm <sup>2</sup>	Ethernet CAT 5e, 100 Mbit <sup>i</sup>
E	<b>Media</b>				
	Air (PROC 1)		1	12.5 mm inner diameter	Max. air pressure 16 bar/230 PSI
F	<b>Functional Earth<sup>ii</sup></b>		1	10 mm <sup>2</sup>	600 V AC RMS

<sup>i</sup> Ethernet with wire colors according to PROFINET standard, M12-connectors.

<sup>ii</sup> When EtherNet is selected.

Continues on next page

### 3 Specification of variants and options

#### 3.4.4 Configuration result of DressPack options

*Continued*

#### DressPack options for spotwelding (SW)

The DressPack contents will differ depending on selected options. See table for signal content below.

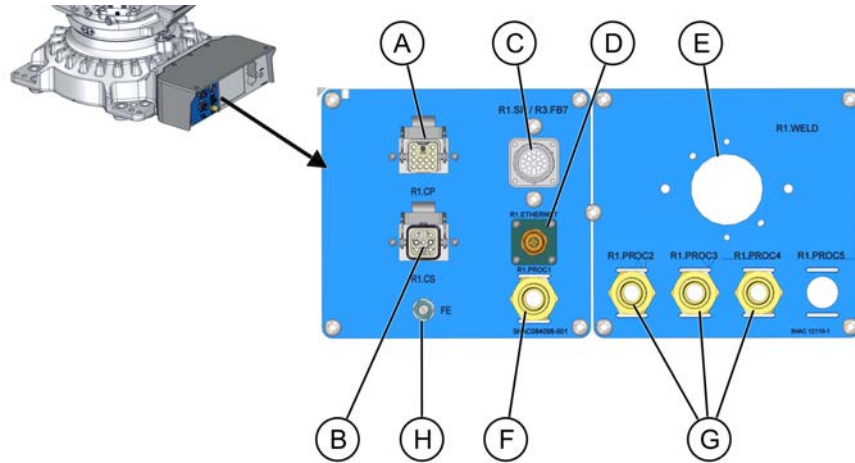

xx2300000250

A	Customer power (CP)
B	Customer signal (CS)
C	Servo Power (SP)
D	ETHERNET
E	WELD3 x 35 mm <sup>2</sup> (spot welding)
F	PROC1 (1/2" hose, M22 x 1.5, 24 degree seal)
G	PROC2-4 (spot welding 1/2", M22 x 1.5, 24 degree seal)
H	Functional earth (FE)

	Type	At terminals in cabinet	At connection point; base, axis 3, or axis 6	Cable/part area	Allowed capacity
A	<b>Customer Power (CP)</b>				
	Utility power	3	3	1.5 mm <sup>2</sup>	250 V AC, 10 A rms
	Protective earth	1	1	1.5 mm <sup>2</sup>	250 V AC
	Utility power	4	4	0.5 mm <sup>2</sup>	50 V DC, 1 A rms
B	<b>Customer Signal (CS)</b>				
	Signals shielded		8 (4x2)	0.24 mm <sup>2</sup>	30 V AC, 42 V DC, 1 A rms
C	<b>Servo motor signals (SP)</b>				
	Servo motor power	At drive	3	1.5 mm <sup>2</sup>	600 VAC, 12 A rms
	Protective earth	At drive	1	1.5 mm <sup>2</sup>	600 VAC
	Brake		2	0.5 mm <sup>2</sup>	50 V DC, 1 A rms
	Temperature control/PTC		2	0.5 mm <sup>2</sup>	50 V DC, 1 A rms

*Continues on next page*

### 3 Specification of variants and options

#### 3.4.4 Configuration result of DressPack options

Continued

	Type	At terminals in cabinet	At connection point; base, axis 3, or axis 6	Cable/part area	Allowed capacity
D	<b>Customer bus (Ethernet)</b>				
	Bus signals	4	4	0.4 mm <sup>2</sup>	Ethernet CAT 5e, 100 Mbit <sup>i</sup>
E	<b>Welding power (WELD3 x 35 mm<sup>2</sup>)</b>				
	Lower and upper arm		2	35 mm <sup>2</sup> ii	600 VAC, 150 A rms at 20°C (68°F)
	Protective earth (lower and upper arm)		1		
F	<b>Media</b>				
	Air (PROC 1)		1	12.5 mm inner diameter	Max. air pressure 16 bar/230 PSI
G	<b>Media</b>				
	(PROC2-4)		3	12.5 mm inner diameter M22 x 1.5, 24 degree seal	Max. air pressure 16 bar/230 PSI
H	<b>Functional Earth</b> iii		1	10 mm <sup>2</sup>	600 V AC RMS

i Ethernet with wire colors according to PROFINET standard, M12-connectors.

ii For LeanID upper arm 25 mm<sup>2</sup>, 135 A rms

iii When EtherNet is selected.

#### Empty conduit options

The dimension and requirements for empty cable conduit options are described in the product manual for the DressPack, see [References on page 7](#).

### 3.4.5 Connector kits manipulator

#### 3.4.5.1 Base - Connector kits

##### Available options

Option	Name	DressPack options	
		3325-11/13	3325-61/63
3330-2	CP/CS bus, Proc 1 base	X	X
3331-1	Weld Proc 2-4 base		X
3332-1	FB7 on base	X	



##### Note

Servo power connector kits are not available.

##### Option 3330-2, CP/CS bus, Proc 1 on base

This option offers a kit with connectors. This must be assembled by the customer. The kit contains the following components.



xx240000941

CP

Amount	Description	Size, material, etc.	Brand
1	Hood pegs, Han 3A		Harting
1	Insert, female, 12p		Harting
8	Crimp contact female <sup>i</sup>	For 0.5 mm <sup>2</sup> Han D, silver plated	Harting
8	Crimp contact female <sup>i</sup>	For 1.0 mm <sup>2</sup> Han D, silver plated	Harting

*Continues on next page*

### 3 Specification of variants and options

#### 3.4.5.1 Base - Connector kits

Continued

Amount	Description	Size, material, etc.	Brand
8	Crimp contact female <sup>i</sup>	For 1.5 mm <sup>2</sup> Han D, silver plated	Harting
8	Crimp contact female <sup>i</sup>	For 2.5 mm <sup>2</sup> Han D, silver plated	Harting
2	Coding pin, Han		Harting
1	Screw M3 with seal		Harting
1	Cable gland	For cable diameter 9-13 mm	

<sup>i</sup> For recommended crimp tool, see manufacturer website.

#### CS

Amount	Description	Size, material, etc.	Brand
1	Hood pegs, Han 3A		Harting
1	Insert, female, 8p		Harting
8	Crimp contact female <sup>i</sup>	For 0.14– 0.37 mm <sup>2</sup> Han D, silver plated	Harting
1	Screw M3 with seal		Harting
1	Cable gland	For cable diameter 6.5-9.5 mm	

<sup>i</sup> For recommended crimp tool, see manufacturer website.

#### Media

Amount	Description	Size, material, etc.	Brand
1	Hose coupling	1/2", M22 x 1.5 Brass	

#### Ethernet

Amount	Description	Size, material, etc.	Brand
1	M12 Connector, Male, D-code <sup>i</sup>	For 0.14–0.34 mm <sup>2</sup> , for cable diameter 4.5-8.8 mm	

<sup>i</sup> Assembly instruction is included in delivery.

Continues on next page

### 3 Specification of variants and options

#### 3.4.5.1 Base - Connector kits

*Continued*

#### Option 3331-1, Weld Proc 2-4 base

This option offers a kit with connectors. This must be assembled by the customer. The kit contains the following components.



xx240000942

#### WELD

Amount	Description	Size, material, etc.	Brand
1	Welding connector socket	TSB150/L-UR	Stäubli
3	Socket <sup>i</sup>	For 35 mm <sup>2</sup>	Stäubli
1	Form shroud welding conn.	202K174-3/42-0, for cable diameter 15.7-35 mm	Raychem

<sup>i</sup> For recommended crimp tool, see manufacturer website.

#### Media

Amount	Description	Size, material, etc.	Brand
4	Hose coupling	1/2", M22 x 1.5 Brass	

*Continues on next page*

### 3 Specification of variants and options

#### 3.4.5.1 Base - Connector kits

*Continued*

##### Option 3332-1, FB7 on base

This option offers a kit with connectors. This must be assembled by the customer. The kit contains the following components.



xx2400000943

FB

Amount	Description	Size, material, etc.	Brand
1	Connector, 8p, Male	UTOW	
15	Pin	For 0.13–0.26 mm <sup>2</sup>	
1	Shrink boot adapter		
1	Bottle shaped shrink boot		

#### 3.4.5.2 Axis 3 - Connector kits

##### Available options

Option	Name	DressPack options	
		3326-11/13	3326-61/63
3333-2	CP/CS bus, Proc 1 axis 3	X	X
3333-3	CP/CS Proc1, Servo & FB		X

##### Option 3333-2, CP/CS/CBus, Proc 1 axis 3

This option offers a kit with connectors. This must be assembled by the customer. The kit contains the following components.



xx240000944

##### CP

Amount	Description	Size, material, etc.	Brand
1	Hood pegs, Han 3A		Harting
1	Insert, male, 12p		Harting
8	Crimp contact male <sup>i</sup>	For 0.5 mm <sup>2</sup> Han D, silver plated	Harting
8	Crimp contact male <sup>i</sup>	For 1.0 mm <sup>2</sup> Han D, silver plated	Harting
8	Crimp contact male <sup>i</sup>	For 1.5 mm <sup>2</sup> Han D, silver plated	Harting
8	Crimp contact male <sup>i</sup>	For 2.5 mm <sup>2</sup> Han D, silver plated	Harting
2	Coding pin, Han		Harting
1	Screw M3 with seal		Harting

*Continues on next page*

### 3 Specification of variants and options

#### 3.4.5.2 Axis 3 - Connector kits

Continued

Amount	Description	Size, material, etc.	Brand
1	Cable gland	For cable diameter 9-13 mm	

<sup>i</sup> For recommended crimp tool, see manufacturer website.

CS

Amount	Description	Size, material, etc.	Brand
1	Hood pegs, Han 3A		Harting
1	Insert, male, 8p		Harting
8	Crimp contact male <sup>i</sup>	For 0.14– 0.37 mm <sup>2</sup> Han D, silver plated	Harting
1	Screw M3 with seal		Harting
1	Cable gland	For cable diameter 6.5-9.5 mm	

<sup>i</sup> For recommended crimp tool, see manufacturer website.

Media

Amount	Description	Size, material, etc.	Brand
1	Hose coupling Parker Push lock	1/2", M22 x 1.5 Brass	

Ethernet

Amount	Description	Size, material, etc.	Brand
1	M12 Connector, Male, D-code <sup>i</sup>	For 0.14–0.34 mm <sup>2</sup> , for cable diameter 4.5-8.8 mm	

<sup>i</sup> Assembly instruction is included in delivery.

#### Option 3333-3, CP/CS Proc1, Servo & FB

This option offers a kit with connectors. This must be assembled by the customer. The kit contains the following components.



xx240000945

Continues on next page

### 3 Specification of variants and options

#### 3.4.5.2 Axis 3 - Connector kits

*Continued*

CP

Amount	Description	Size, material, etc.	Brand
1	Hood pegs, Han 3A		Harting
1	Insert, male, 12p		Harting
8	Crimp contact male <sup>i</sup>	For 0.5 mm <sup>2</sup> Han D, silver plated	Harting
8	Crimp contact male <sup>i</sup>	For 1.0 mm <sup>2</sup> Han D, silver plated	Harting
8	Crimp contact male <sup>i</sup>	For 1.5 mm <sup>2</sup> Han D, silver plated	Harting
8	Crimp contact male <sup>i</sup>	For 2.5 mm <sup>2</sup> Han D, silver plated	Harting
2	Coding pin, Han		Harting
1	Screw M3 with seal		Harting
1	Cable gland	For cable diameter 9-13 mm	

<sup>i</sup> For recommended crimp tool, see manufacturer website.

CS

Amount	Description	Size, material, etc.	Brand
1	Hood pegs, Han 3A		Harting
1	Insert, male, 8p		Harting
8	Crimp contact male <sup>i</sup>	For 0.14– 0.37 mm <sup>2</sup> Han D, silver plated	Harting
1	Screw M3 with seal		Harting
1	Cable gland	For cable diameter 6.5-9.5 mm	

<sup>i</sup> For recommended crimp tool, see manufacturer website.

Media

Amount	Description	Size, material, etc.	Brand
1	Hose coupling Parker Push lock	1/2", M22 x 1.5 Brass	

Ethernet

Amount	Description	Size, material, etc.	Brand
1	M12 Connector, Male, D-code <sup>i</sup>	For 0.14–0.34 mm <sup>2</sup> , for cable diameter 4.5-8.8 mm	

<sup>i</sup> Assembly instruction is included in delivery.

SP

Amount	Description	Size, material, etc.	Brand
1	Hood pegs, Han 3A		Harting
1	Insert, male, 12p		Harting

*Continues on next page*

### 3 Specification of variants and options

#### 3.4.5.2 Axis 3 - Connector kits

Continued

Amount	Description	Size, material, etc.	Brand
8	Crimp contact male <sup>i</sup>	For 0.5 mm <sup>2</sup> Han D, silver plated	Harting
8	Crimp contact male <sup>i</sup>	For 1.0 mm <sup>2</sup> Han D, silver plated	Harting
8	Crimp contact male <sup>i</sup>	For 1.5 mm <sup>2</sup> Han D, silver plated	Harting
8	Crimp contact male <sup>i</sup>	For 2.5 mm <sup>2</sup> Han D, silver plated	Harting
2	Coding pin, Han		Harting
1	Screw M3 with seal		Harting
1	Cable gland	For cable diameter 9-13 mm	

<sup>i</sup> For recommended crimp tool, see manufacturer website.

FB

Amount	Description	Size, material, etc.	Brand
1	Hood pegs, Han 3A		Harting
1	Insert, male, 8p		Harting
8	Crimp contact male <sup>i</sup>	For 0.14– 0.37 mm <sup>2</sup> Han D, silver plated	Harting
1	Screw M3 with seal		Harting
1	Coding pin, Han D, female		Harting
1	Cable gland	For cable diameter 6.5-9.5 mm	

<sup>i</sup> For recommended crimp tool, see manufacturer website.

#### 3.4.5.3 Axis 6 - Connector kits

##### Available options

Option	Name	DressPack options	
		3326-11/13	3326-61/63
3334-2	CP/CS bus axis 6	X	X
3334-3	CP/CS Proc1, Servo & FB		X
3335-1	Weld Proc 2-4 axis6		X

##### Option 3334-2, CP/CS/CBus, Proc 1 axis 6

This option offers a kit with connectors. This must be assembled by the customer. The kit contains the following components.



xx2400000946

##### CP

Amount	Description	Size, material, etc.	Brand
1	Hood pegs, Han 3A		Harting
1	Insert, male, 12p		Harting
8	Crimp contact male <sup>i</sup>	For 0.5 mm <sup>2</sup> Han D, silver plated	Harting
8	Crimp contact male <sup>i</sup>	For 1.0 mm <sup>2</sup> Han D, silver plated	Harting
8	Crimp contact male <sup>i</sup>	For 1.5 mm <sup>2</sup> Han D, silver plated	Harting
8	Crimp contact male <sup>i</sup>	For 2.5 mm <sup>2</sup> Han D, silver plated	Harting
2	Coding pin, Han		Harting

*Continues on next page*

### 3 Specification of variants and options

#### 3.4.5.3 Axis 6 - Connector kits

Continued

Amount	Description	Size, material, etc.	Brand
1	Screw M3 with seal		Harting
1	Cable gland	For cable diameter 9-13 mm	

<sup>i</sup> For recommended crimp tool, see manufacturer website.

#### CS

Amount	Description	Size, material, etc.	Brand
1	Hood pegs, Han 3A		Harting
1	Insert, male, 8p		Harting
8	Crimp contact male <sup>i</sup>	For 0.14– 0.37 mm <sup>2</sup> Han D, silver plated	Harting
1	Screw M3 with seal		Harting
1	Cable gland	For cable diameter 6.5-9.5 mm	

<sup>i</sup> For recommended crimp tool, see manufacturer website.

#### Media

Amount	Description	Size, material, etc.	Brand
1	Hose coupling Parker Push lock	1/2", M22 x 1.5 Brass	

#### Ethernet

Amount	Description	Size, material, etc.	Brand
1	M12 Connector, Female, D-code	For cable diameter 5.7– 8.8 mm	Harting
4	Socket <sup>i</sup>	D-sub, FE AWG 22-26	Harting

<sup>i</sup> For recommended crimp tool, see manufacturer website.

Continues on next page

### 3 Specification of variants and options

#### 3.4.5.3 Axis 6 - Connector kits

*Continued*

#### Option 3334-3, CP/CS Proc 1, Servo & FB

This option offers a kit with connectors. This must be assembled by the customer. The kit contains the following components.



xx2400000947

#### CP

Amount	Description	Size, material, etc.	Brand
1	Hood pegs, Han 3A		Harting
1	Insert, male, 12p		Harting
8	Crimp contact male <sup>i</sup>	For 0.5 mm <sup>2</sup> Han D, silver plated	Harting
8	Crimp contact male <sup>i</sup>	For 1.0 mm <sup>2</sup> Han D, silver plated	Harting
8	Crimp contact male <sup>i</sup>	For 1.5 mm <sup>2</sup> Han D, silver plated	Harting
8	Crimp contact male <sup>i</sup>	For 2.5 mm <sup>2</sup> Han D, silver plated	Harting
2	Coding pin, Han		Harting
1	Screw M3 with seal		Harting
1	Cable gland	For cable diameter 9-13 mm	

<sup>i</sup> For recommended crimp tool, see manufacturer website.

#### CS

Amount	Description	Size, material, etc.	Brand
1	Hood pegs, Han 3A		Harting
1	Insert, male, 8p		Harting
8	Crimp contact male <sup>i</sup>	For 0.14–0.37 mm <sup>2</sup> Han D, silver plated	Harting

*Continues on next page*

### 3 Specification of variants and options

#### 3.4.5.3 Axis 6 - Connector kits

Continued

Amount	Description	Size, material, etc.	Brand
1	Screw M3 with seal		Harting
1	Cable gland	For cable diameter 6.5-9.5 mm	

<sup>i</sup> For recommended crimp tool, see manufacturer website.

#### Media

Amount	Description	Size, material, etc.	Brand
1	Hose coupling Parker Push lock	1/2", M22 x 1.5 Brass	

#### Ethernet

Amount	Description	Size, material, etc.	Brand
1	M12 Connector, Female, D-code	For cable diameter 5.7–8.8 mm	Harting
4	Socket <sup>i</sup>	D-sub, FE AWG 22-26	Harting

<sup>i</sup> For recommended crimp tool, see manufacturer website.

#### SP

Amount	Description	Size, material, etc.	Brand
1	M23 Hybrid Panel Connector, 8p, Male	For cable diameter 7.0–12.0 mm	Hummel
4	Crimp pin 1 mm, AWG 24-17 <sup>i</sup>	For 0.25–1.0 mm <sup>2</sup>	Hummel
4	Crimp pin 2 mm, AWG 18-24 <sup>i</sup>	For 0.75–2.5 mm <sup>2</sup>	Hummel
4	Crimp pin 2 mm, AWG 14-12 <sup>i</sup>	For 2.5–4.0 mm <sup>2</sup>	Hummel

<sup>i</sup> For recommended crimp tool, see manufacturer website.

#### FB

Amount	Description	Size, material, etc.	Brand
1	M23 Signal Panel Connector, 12p, Male	For cable diameter 7.0–12.0 mm	Hummel
12	Pin AWG 28-20 <sup>i</sup>	For 0.08–0.56 mm <sup>2</sup>	Hummel
12	Pin AWG 26-17 <sup>i</sup>	For 0.14–1.0 mm <sup>2</sup>	Hummel
12	Pin AWG 18-16 <sup>i</sup>	For 0.75–1.5 mm <sup>2</sup>	Hummel

<sup>i</sup> For recommended crimp tool, see manufacturer website.

Continues on next page

### 3 Specification of variants and options

#### 3.4.5.3 Axis 6 - Connector kits

*Continued*

#### Option 3335-1, Weld Proc 2-4 axis6

This option offers a kit with connectors. This must be assembled by the customer. The kit contains the following components.



xx2400000948

#### WELD

Amount	Description	Size, material, etc.	Brand
1	Welding connector	RobiFix-B-L	Stäubli
3	Socket <sup>i</sup>	For 25 mm <sup>2</sup>	Stäubli

<sup>i</sup> For recommended crimp tool, see manufacturer website.

#### Media

Amount	Description	Size, material, etc.	Brand
4	Hose coupling Parker Push lock	1/2", M22 x 1.5 Brass	

### 3 Specification of variants and options

#### 3.4.6 Application floor cables

#### 3.4.6 Application floor cables

##### Parallel cable - Length

Option	Description	Note
3201-2	7 m	
3201-3	15 m	
3201-4	22 m	
3201-5	30 m	

##### Ethernet cable - Length



##### Note

Occupies 1 Ethernet port.

Option	Description	Note
3202-2	7 m	Includes Parallel cable
3202-3	15 m	Includes Parallel cable
3202-4	22 m	Includes Parallel cable
3202-5	30 m	Includes Parallel cable

##### CC-Link cable - Length

Option	Description	Note
3205-2	7 m	Includes Parallel cable
3205-3	15 m	Includes Parallel cable
3205-4	22 m	Includes Parallel cable
3205-5	30 m	Includes Parallel cable

##### Servo cable 1 axis - Length

Option	Description	Note
3206-2	7 m	
3206-3	15 m	
3206-4	22 m	
3206-5	30 m	

##### EtherCat cable - Length



##### Note

Occupies 1 Ethernet port.

Option	Description	Note
3210-2	7 m	Includes Parallel cable

*Continues on next page*

### 3 Specification of variants and options

#### 3.4.6 Application floor cables

*Continued*

Option	Description	Note
3210-3	15 m	Includes Parallel cable
3210-4	22 m	Includes Parallel cable
3210-5	30 m	Includes Parallel cable

#### MCB Servo cable 1 axis

Option	Description	Note
3212-2	7 m	

#### Requirements

This option requires options DressPack base-axis 3 and Motor Connection Kit [3069-x].

## 3 Specification of variants and options

### 3.5 Warranty

### 3.5 Warranty

#### Warranty

For the selected period of time, ABB will provide spare parts and labor to repair or replace the non-conforming portion of the equipment without additional charges. During that period, it is required to have a yearly *Preventative Maintenance* according to ABB manuals to be performed by ABB. If due to customer restrains no data can be analyzed with ABB Connected Services for robots with OmniCore controllers, and ABB has to travel to site, travel expenses are not covered. The *Extended Warranty* period always starts on the day of warranty expiration. Warranty Conditions apply as defined in the *Terms & Conditions*.



#### Note

This description above is not applicable for option *Stock warranty* [438-8]

Option	Type	Description
438-1	Standard warranty	Standard warranty is 12 months from <i>Customer Delivery Date</i> or latest 18 months after <i>Factory Shipment Date</i> , whichever occurs first. Warranty terms and conditions apply.
438-2	Standard warranty + 12 months	Standard warranty extended with 12 months from end date of the standard warranty. Warranty terms and conditions apply. Contact Customer Service in case of other requirements.
438-4	Standard warranty + 18 months	Standard warranty extended with 18 months from end date of the standard warranty. Warranty terms and conditions apply. Contact Customer Service in case of other requirements.
438-5	Standard warranty + 24 months	Standard warranty extended with 24 months from end date of the standard warranty. Warranty terms and conditions apply. Contact Customer Service in case of other requirements.
438-6	Standard warranty + 6 months	Standard warranty extended with 6 months from end date of the standard warranty. Warranty terms and conditions apply.
438-7	Standard warranty + 30 months	Standard warranty extended with 30 months from end date of the standard warranty. Warranty terms and conditions apply.
438-8	Stock warranty	<p>Maximum 6 months postponed start of standard warranty, starting from factory shipment date. Note that no claims will be accepted for warranties that occurred before the end of stock warranty. Standard warranty commences automatically after 6 months from <i>Factory Shipment Date</i> or from activation date of standard warranty in WebConfig.</p> <p> <b>Note</b></p> <p>Special conditions are applicable, see <i>Robotics Warranty Directives</i>.</p>

# Index

## A

Absolute Accuracy, 70  
Absolute Accuracy, calibration, 64  
ambient humidity  
  operation, 27  
  storage, 27  
ambient temperature  
  operation, 27  
  storage, 27  
Axis Calibration  
  calibration tool  
    article number, 69

## B

base plate, 51

## C

calibration  
  Absolute Accuracy type, 63  
  standard type, 63  
calibration, Absolute Accuracy, 64  
calibration marks, 65  
calibration position  
  scales, 65  
calibration scales, 65  
CalibWare, 63  
compensation parameters, 70

## D

dimensions  
  robot, 39  
direction of axes, 67

## E

equipment, robot, 39  
extended working range, 133  
extension zone concept, 89  
extension zone limits, 89  
extra equipment, 39

## F

fitting, equipment, 39  
foundation  
  requirements, 27

## H

humidity  
  operation, 27  
  storage, 27

## I

installation  
  equipment, 39

## L

limitations, 90  
load, 88  
loads on foundation, 26

## M

maintenance, 23  
mounting, equipment, 39  
movable mechanical stop, 61

## N

negative directions, axes, 67

## O

operating conditions, 27  
option  
  Extended working range, 133  
options, 127

## P

positive directions, axes, 67  
product standards, 22  
protection classes, 28  
protection type, 28

## R

requirements on foundation, 27  
robot  
  dimensions, 39  
  equipment, fitting, 39  
  protection class, 28  
  protection types, 28  
  technical data, 25  
  working range, 31

## S

safety standards, 22  
scales on robot, 65  
securing the robot to foundation, attachment screws, 49  
speed, 90  
standards, 22  
standard warranty, 166  
stock warranty, 166  
stopping distance, 90  
stopping time, 90  
storage conditions, 27  
sync marks, 65

## T

technical data  
  robot, 25  
temperatures  
  operation, 27  
  storage, 27  
torques on foundation, 26  
troubleshooting, 23  
turning radius, 35

## V

variants, 127

## W

warranty, 166  
wcp, 89  
weight, 25  
working range, 36  
  robot, 31







**ABB Robotics Sweden AB**  
**S-721 71 VÄSTERÅS, Sweden**  
Telephone +46 10-732 50 00

**ABB Robotics Norway AS**  
**Nordlysvegen 7, N-4340 BRYNE, Norway**  
Box 265, N-4349 BRYNE, Norway  
Telephone: +47 22 87 2000

**ABB Robotics (Shanghai) Limited**  
No. 39, 99 Miaoqiao Road,  
Pudong New Area,  
Shanghai, 201315, China  
Telephone: +86 21 6105 6666

**ABB Robotics LLC**  
**1250 Brown Road**  
Auburn Hills, MI 48326  
USA  
Telephone: +1 248 391 9000

**[abb.com/robotics](http://abb.com/robotics)**