

**VEICHI**

# VH Series Compact PLC



**VEICHI**

**Suzhou Veichi Electric Co.,Ltd.**

No.1888 Songwei Road, Guoxiang Street, Wuzhong Economic and Technological Development Zone, Suzhou, Jiangsu Province, China.

Tel:+86-512-6617 1988 Fax:+86-512-6617 3610

Facebook: <https://www.facebook.com/veichigroup>

WhatsApp:+86-138 2881 8903 <https://www.veichi.org>



Official Website

\*Version: Y5/2-11  
Information in this manual is subject to change without notice.  
Copyright © Veichi Electric. All rights reserved. Unauthorized reproduction prohibited.

Stock Code: 688698

# About Us



Veichi Electric (Stock Code: 688698) specializes in electrical transmission and industrial control, operating as an integrated high-tech enterprise in R&D, production, and sales of industrial automation products. With a vision to lead in smart industry and green energy solutions, the company leverages its R&D and manufacturing hubs in Suzhou, additional R&D centers in Shenzhen and Xi'an, and wholly-owned subsidiaries overseas, consistently serving customers worldwide with competitive and reliable solutions.

Under the "One Core, Two New Drivers" strategy, Veichi focuses on industrial automation, offering AC drives, servo systems, and control systems widely applied across heavy and light industries, as well as high-end equipment sectors, supporting the digital and intelligent transformation of manufacturing with its tailored solutions. Simultaneously, in two emerging fields, it provides one-stop solutions for humanoid, collaborative, and mobile robots in embodied intelligence, while in green energy, it delves into segments like photovoltaic, energy storage, and hydrogen energy, to "connect every device with green power," fostering a synergistic growth between core operations and new ventures.

Sustained R&D has yielded a portfolio of proprietary patented technologies including silicon carbide application, HF injection, motor controls and protections (auto-tuning, flying-start, high-speed flux-weakening, V/F control, vector control), high-density water-cooling layout, and IGBT drive protection. As of September 30, 2025, Veichi holds 234 patents, with 66 for invention.

Over two decades of steady growth, Veichi has earned numerous certifications and accolades from national and regulatory authorities, including "High-Tech Enterprise," "Postdoctoral Research Workstation," and provincial honors like "Engineering Technology Research Center," "Enterprise Technology Center," and "Industrial Internet Development Demonstration Enterprise (Benchmark Factory Category)."

Guided by its mission to "Drive Smart Industry, Co-create a Green Future," Veichi will continue to intensify R&D and advance into high-performance, high-reliability fields to propel global progress.

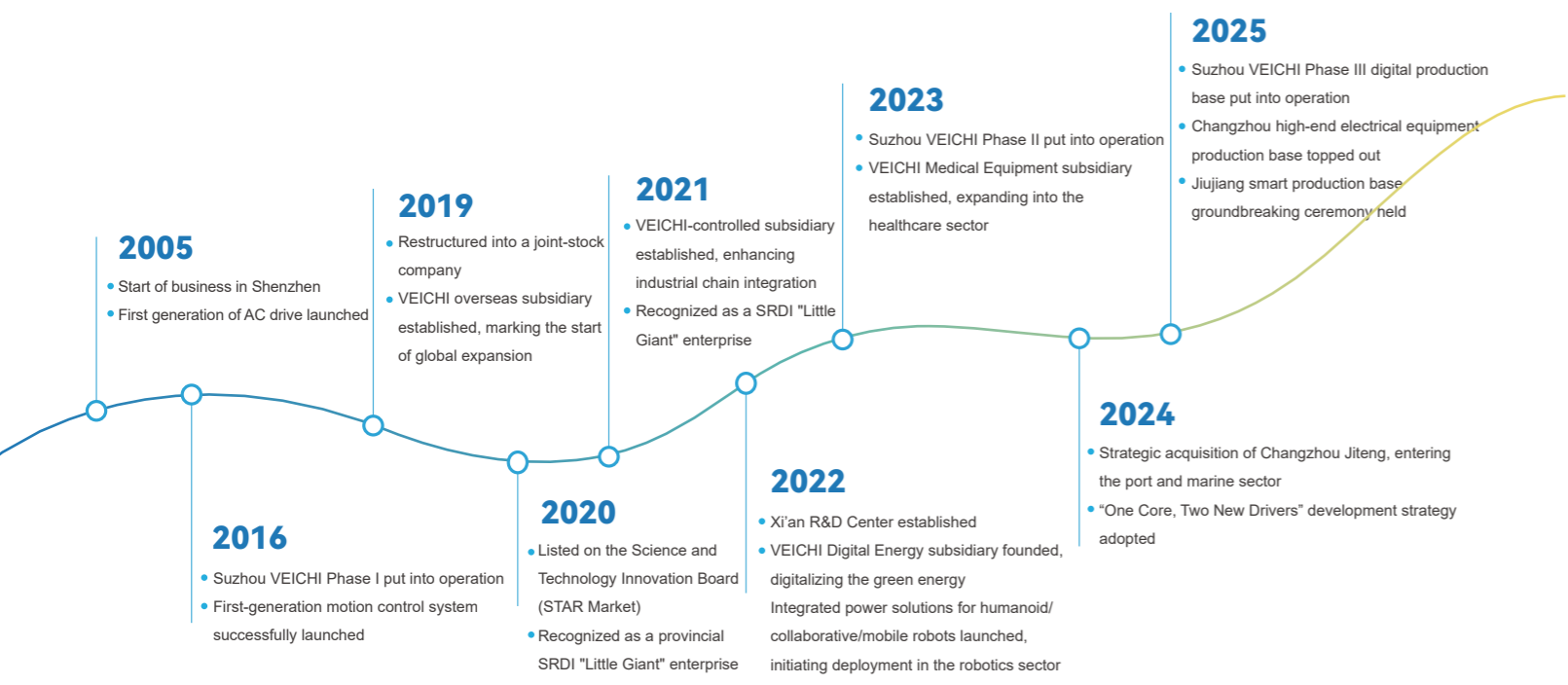

## Product Profile



### VH Series Compact PLC:

This lineup includes the VH100, VH200, VH300, VH500, VH600, and VH series remote modules, covering the applications from small to medium-sized automation control in multi-axis motion control, temperature and other analog control, as well as communication networking. The slim footprint allows more expansion boards and modules to fit in the narrow space without compromise on performance. A variety of industrial network communication protocols are integrated for easier data acquisition with other devices on site. And the programming software is continuously updated with more functions and easy operation in line with the customer needs.

## Product Orientation

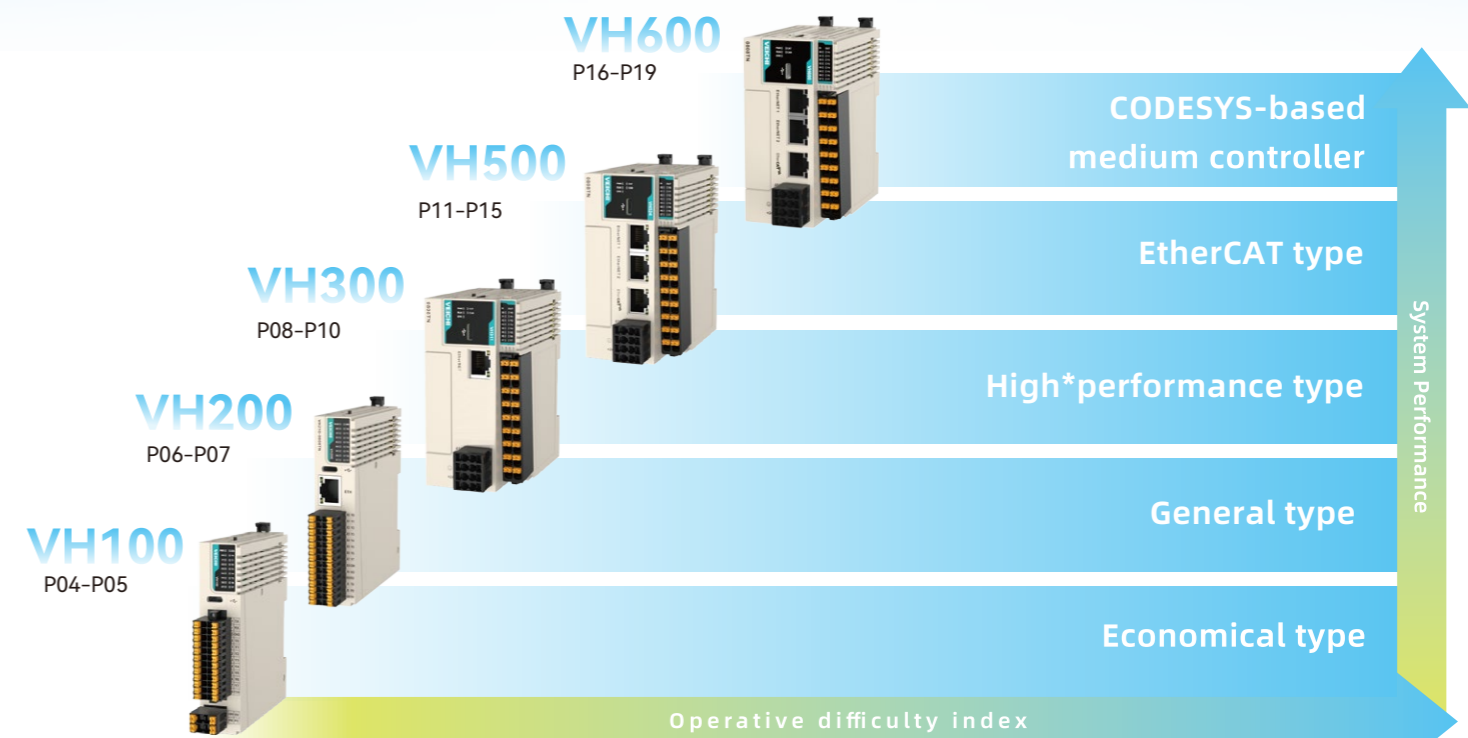

Note: For expansion modules related to the VH series products, please refer to pages 22-36 and for temperature controllers, please refer to pages 20-21 of this manual.

## Product Features

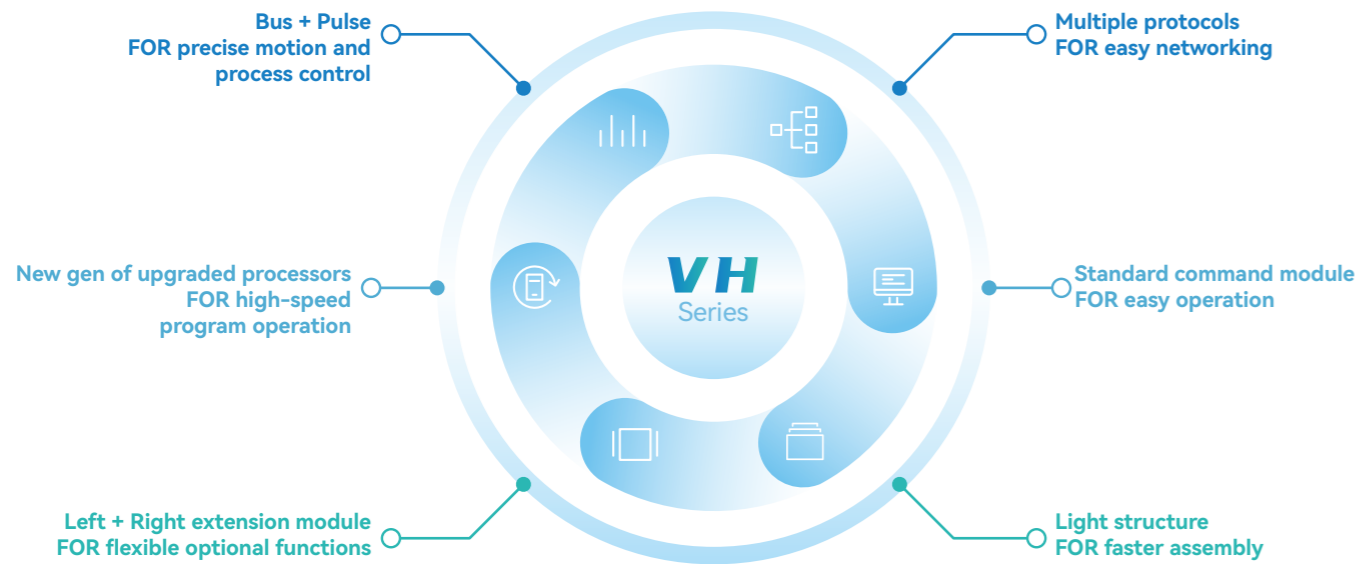

## Naming Rules

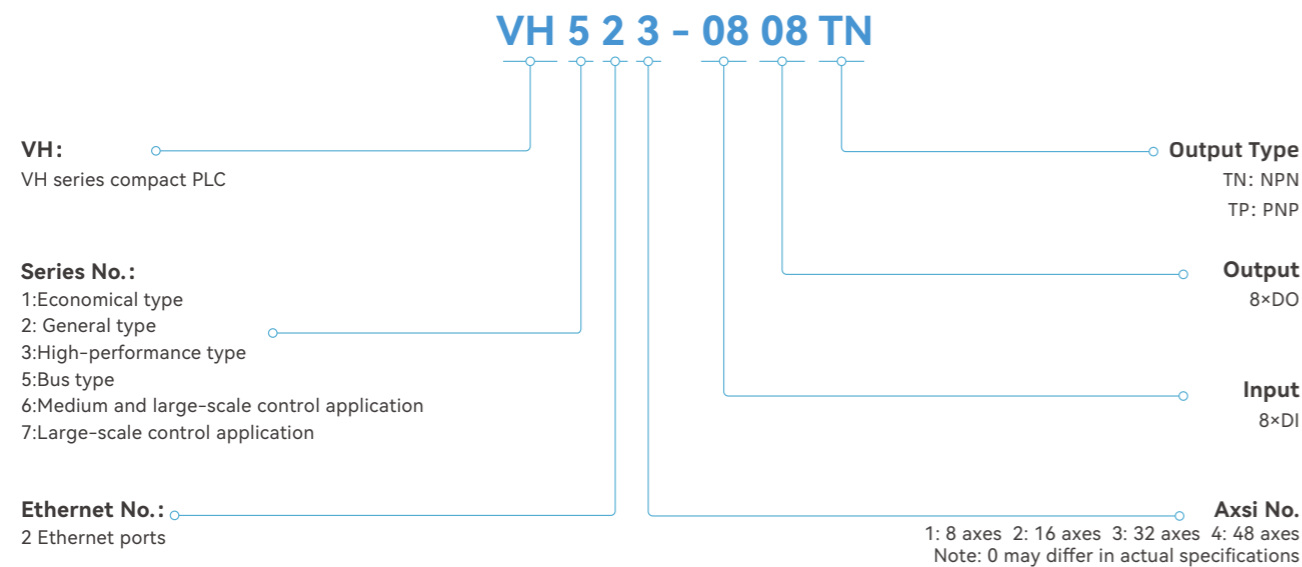

# VH100-0808TN

## Economical Type

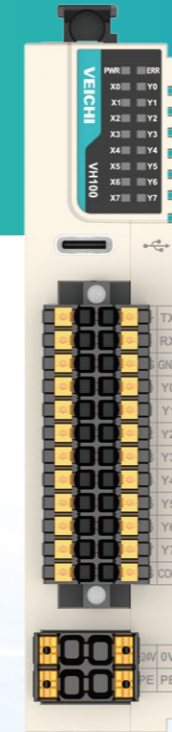

- Stand-alone PLC
- Narrow scenario application
- Excellent price/performance ratio
- RS-232 and RS-485 communication
- 8×DI and 8×DO
- Small-scale automation application

## Product Features

### 8 × HSC

2×high-spped counting(50kHz)  
6×high-spped counting(10kHz)  
Single/two-phase(Up/Down) and  
AB phase(1x and 4x) counting

### Serial Comm Port

1×RS232 and 1×RS485  
COM0 and COM1 respectively, up to 115.2K  
COM0 for programming port and Modbus RTU slave  
COM1 for Modbus RTU master and slave, FreePort and N:N  
Built-in termination resistor selected by dip switch

### 3 × PTO

3×high-speed pulse train output(100kHz)  
Positioning control command  
group for easy start

### USB Port

USB2.0  
Common Type-C USB cable-compliant  
Quicker firmware upgrade

### Slim Structure

24mm in the width for smaller footprint  
Plug-in wiring for easy maintenance

## Technical Specifications

Item	Specification	
Communication	Interface	2×Asynchronous serial port: COM0 for RS232 and COM1 for RS485. 1×USB interface
	Baud rate	1.2kbps~115.2kbps
	Communication protocol	Modbus/FreePort/N:N
	USB	USB 2.0, Type-C for uploading/downloading/monitoring/firmware update
DI and DO Characteristics	Input type	Sourcing/sinking
	Rated voltage	DC24V, 4mA
	Logic 1 [Voltage range]	> 15VDC
	Logic 0 [Voltage range]	< 5VDC
	Input filter	Digital filter to X0 ~ X7, up to user programs
	Max. leakage current	1mA
	Isolation	2kV capacitor
	High-speed counter	Single-phase: 2×50kHz; 6×10kHz Two-phase: 1×25kHz; 3×5kHz
	Max.pulse output(transistor)	3×100kHz high-speed pulse train output
Common Characteristics	Basic command time	0.2μs
	Program capacity	16k Bytes
	Real-time clock	NO
	Max extension module	NO
	Power-down save	FLASH for permanent save, 2k word elements max
	Power supply	DC24V
	Programming language	Proprietary software AutoStudio with LD, IL and SFC

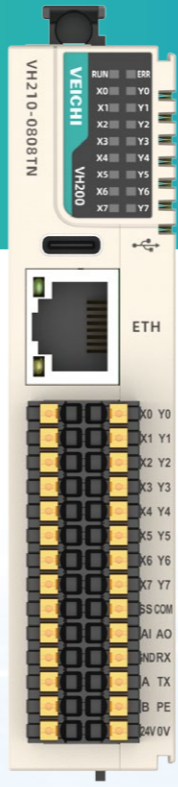

# VH200 Series

## General Type

- Lightweight structure with flexible extensions
- I/O and analog extension modules available according to actual requirements
- Up to 16 right-side extension modules.
- EtherNET, RS-232, RS-485, and other communication compatibility
- Some models standard with built-in analog I/O for flexible configuration

## Product Features

### Flexible Extensions

Slim and compact design with optional right extensions  
Analog/digital I/O control modules available for selection

### Communication & Connectivity

Built-in 1 × EtherNet, 1 × RS232, and 1 × RS485 for basic communication needs

### Built-in Analog I/O

1 × AD and 1 × DA for flexible configuration based on customer requirements

### Ultra-Slim Design

24mm in thickness, ideal for space-constrained wiring scenarios  
Plug-and-play terminal blocks for easy maintenance

## Technical Specifications

Item	VH210-0808TN/P	VH210-0808TN/P1	
Program capacity	32k steps		
Data capacity	84kB for user soft components, about 20kB for power-down save 24kB for user-defined variables, about 8kB for power-down save		
Local extension	16 right extension modules; left extension cards not supported		
Real-time clock	NO		
Programming language	Proprietary software Auto Studio with LD, FBD, SFC		
Ethernet	Modbus-TCP Master/Slave: Former with 6 slaves max; and latter for 4 masters max. TCP free protocol with 4 connections		
RS485	Terminal resistor	1×isolated RS485 port with terminal resistor; master(up to 31 Modbus-RTU slaves)/slave compatibility	
	Baud rate	1.2 kbps ~115.2 kbps	
	Communication protocol	Modbus/Free Port/N:N	
RS232	1×RS232 USB with baud rate: 1.2 kbps ~ 115.2 kbps		
USB	TYPE-C interface (USB 2.0 Full Speed) for program uploading/downloading, monitoring, and firmware upgrades		
High-speed I/O	Pulse input	2×50 kHz high-speed inputs; 6×10 kHz mid-speed input	
	Pulse output	4×100 kHz high-speed outputs	
Analog specifications	AD input range	NO	1×AI ( 0mA~20mA)
	AD input accuracy	NO	±1% (full scale, @25°C)
	DA output range	NO	1×AO (0mA~20mA)
	DA output accuracy	NO	±1% (full scale, @25°C)



- Slim modular design
- Strong performance with dual CPUs of 600M clock speed
- Improved arithmetic processing
- Multi-channel pulse control application
- 16×right extension modules addable
- 1×left extension board for more functions

## Product Features

### Flexible Extensions

Optional left and right extension boards or modules covering a variety of communication functions and analog/digital I/O control.

### Various Comm Interface

1×RS-485 for CANopen and Modbus TCP master/slave  
TYPE-C port for debugging and SD card for firmware upgrade

### 8×PTO/PTI

8×high-speed pulse train input and output  
Positioning control command group for easy start

### Slim Structure

Vertical structure for smaller footprint  
Quick release terminals for faster maintenance  
Direct wiring with push-in terminals for tool-free installation

### Multiple Motion Control Channels

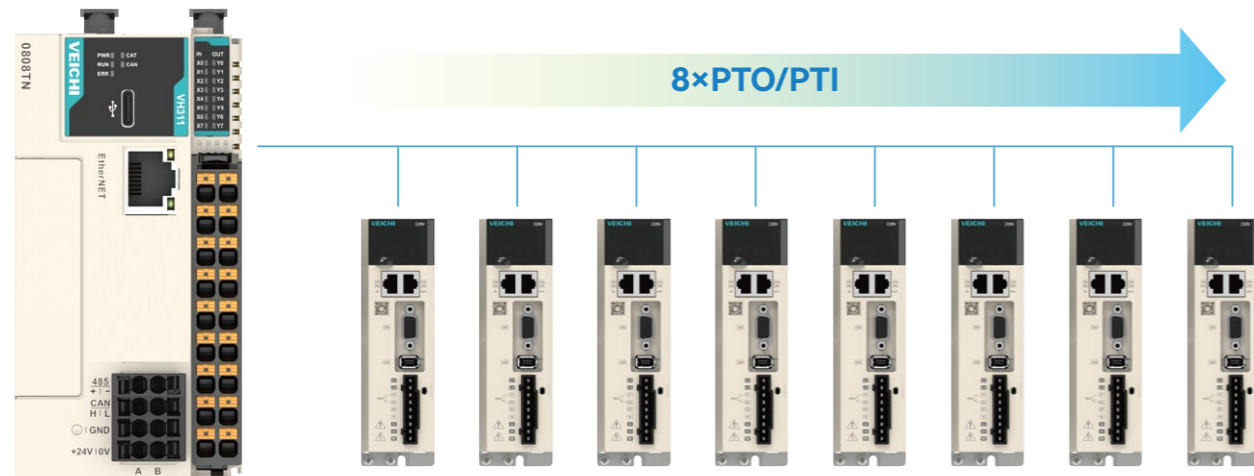

### Linear and Circular Interpolation

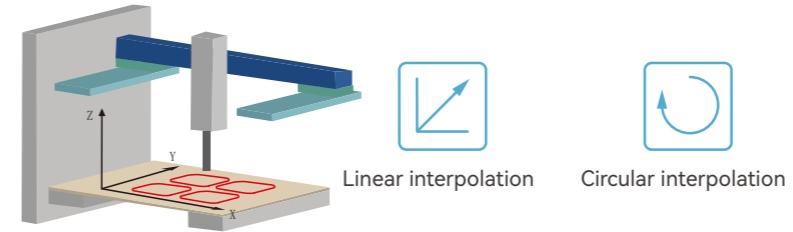

2-axis linear and circular interpolation corresponds to the 2-axis XY platform control to realize the accurate positioning of the slide.

### Electronic Gear and Cam

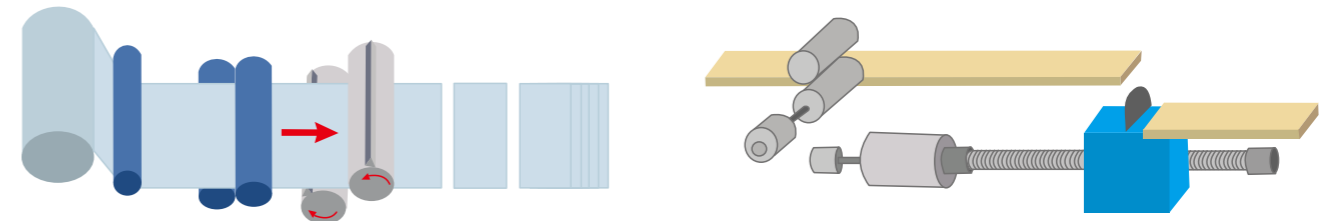

**Flying Shear:** By tracking the progress of the material and setting the cutting length, it can automatically plan the movement trajectory to cut the material at fixed length.

**Chasing Shear:** Set the starting point and length of the sync zone to determine the allowable travel range of the chasing shear axis and the starting point and end point of the round-trip movement, and plan the cam trajectory curve to realize sync cutting.

### Various Motion Control Modes

<b>Single-axis</b>	<b>Speed control</b>	<b>Position control</b>	<b>Home</b>	<b>Torque control</b>
<b>Multiple-axis</b>	<b>Electronic gear</b> Speed sync	<b>Electronic cam</b> Position sync	<b>Interpolation</b> Multiple-axis interpolation	
<b>Others</b>	<b>Rotary cut</b> Easy command for easy operation		<b>Probe</b> High speed and high precision capture	

### Technical Specifications

Item	VH301-0808TN/P	VH311-0808TN/P
Power supply		DC24V
Program capacity		200k steps
Power-down save	128K bytes for user soft components, about 84k bytes for power-down save 1M bytes for user-defined variables, about 128k bytes for power-down save	
Programming language	Proprietary software AutoStudio with LD, IL and SFC	
Right extension No.	16 modules expandable on the right	
Real-time clock	No real-time clock, expandable on the left	
Left extension	1 board	
SD card	For firmware upgrade	
USB	USB 2.0, Type-C for uploading/downloading/monitoring/firmware update	
I/O	Input	8×high-speed pulse train output(200kHz) for single/two-phase(Up/Down) and AB phase (1x and 4x) counting
	Output	8×high-speed pulse train output(100kHz), and positioning control command group supported
Serial Port RS-485	Baud rate	1.2kbps~115.2kbps
	Comm protocol	1×built-in and 2 more expandable on the left for Modbus/FreePort/N:N
	Termination resistor	Built-in, master or slave application, 31 Modbus-RTU slaves max.
CAN	NO	CANopen master with up to 31 slaves
EtherNET	NO	Modbus TCP master/slave for uploading/downloading and monitoring,16 slaves and 4 masters max at the same time.TCP free protocol for 4 connections
Motion control	Positioning control command group, linear and circular interpolation, electronic gear, and electronic cam	



# VH500 Series

## EtherCAT Type

- Slim modular design
- 16×right extension modules and 1× left extension board
- EtherCAT bus control and dual-port network switching
- Process encapsulation and re-application through FB/FC functions
- Multi-level network communication through RS485, Ethernet, CAN and EtherCAT interfaces

### Product Features

#### 1G CPU

Substantial increase in command processing speed over previous products for high speed and high precision motion control and stable process control

#### Multi-level Network

1×RS 485 on the product for CANopen communication, 72 EtherCAT slaves max.  
Dual Ethernet ports for easy networking over levels

#### Bus + Pulse Motion Control

Up to 48 real axes for EtherCAT bus motion control, 64 real and virtual axes in total  
8×high-speed pulse input and output(200kHz)

#### Self-developed Programming Soft

ST in programming to write complex algorithms and logic  
Offline debugging and online modification functions to reduce on-site debugging time  
Function block encapsulation to quick apply the process algorithms

### 48-Axis EtherCAT Control

48-axis high-speed bus control with sync movement for complex production. Fast and precise control for higher end-user benefits.

Simple wiring for lower design and labor cost and quicker maintenance.

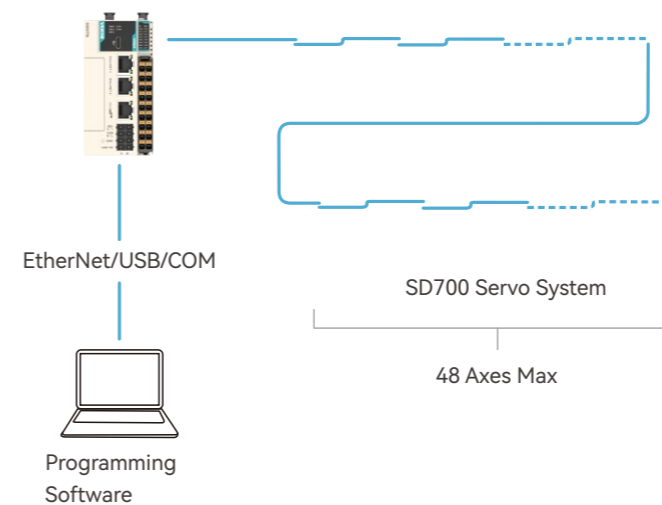

#### Jerk ACC and DEC

Jerk value regulation for smoother ACC/DEC curve and less mechanical shock

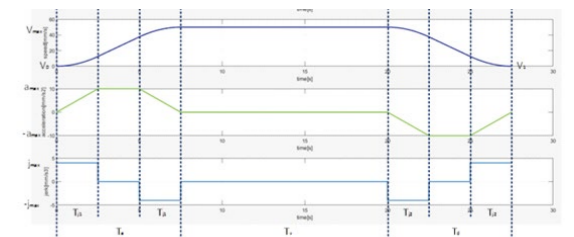

x-coordinat: Time  
1st Y-coordinate: Speed  
2nd Y-coordinate: Acceleration  
3rd Y-coordinate: Acceleration change rate

- Change rate of ACC/DEC speed obtained directly from the ACC/DEC time without calculation
- Change rate visualized in the smoothness of the ACC/DEC curves

Real/visual axes <b>64</b>	Max real axis EtherCAT buses <b>48</b>	Max EtherCAT slaves <b>72</b>
Communication cycle <b>250</b> μs	Sync accuracy <b>±80</b> ns	High-speed I/O <b>8×200</b> kHz

Advanced industrial Ethernet and distributed master/slave

Easy installation for faster information transfer cycle and faster communication and sync

Linear arc interpolation, cams and other modes available

- Motion network bus EtherCAT with communication cycle as fast as 250μs.
- Multi-axis commands such as e-gear and e-cam.
- Single-axis motion commands such as position, speed, and home.
- Main axis for encoder or virtual axis, real axis, external input, etc.
- Servo probe, high-speed counter probe, encoder probe available
- Phase compensation, motion superposition, etc.

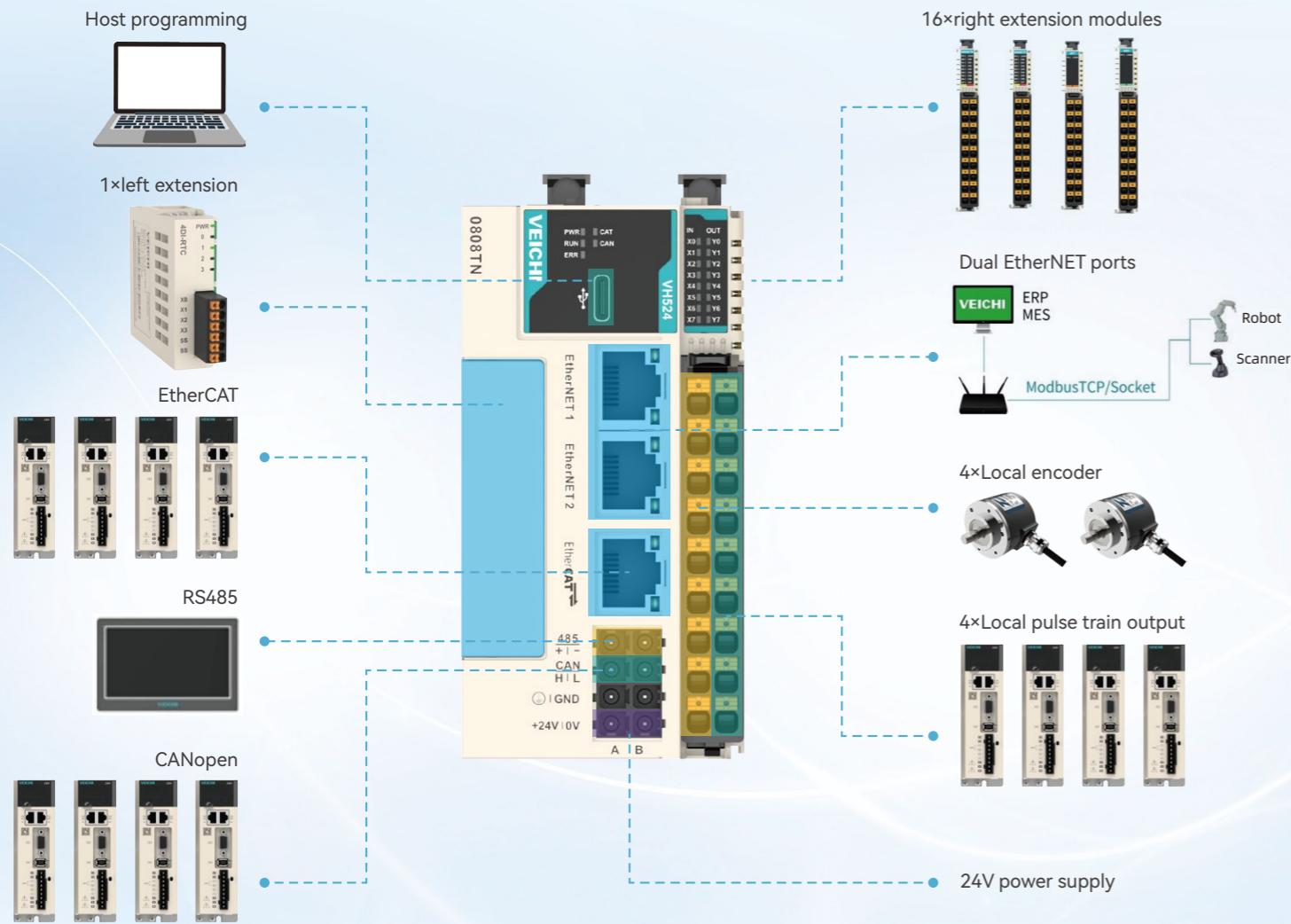

## Multi-level Network One-stop Control

### Technical Specifications

Item	VH511-0808TN/P	VH522-0808TN/P	VH523-0808TN/P	VH524-0808TN/P	
Power supply	DC24V				
Program capacity	200k steps				
Power-down save	128K bytes for user soft components, about 84K bytes for power-down save 1M bytes for user-defined variables, about 128K bytes for power-down save				
Programming language	Proprietary software AutoStudio with LD, IL and SFC				
Right extension No.	16				
Real-time clock	No real-time clock, expandable on the left extension				
Left extension	1 board				
SD card	For firmware upgrade				
USB	USB 2.0, Type-C for uploading/downloading/monitoring/firmware update				
I/O	Input	8	8xhigh-speed pulse train output(200kHz) for single/two-phase(Up/Down) and AB phase(1x and 4x) counting		
	Output	8	8xhigh-speed pulse train output(100kHz), and positioning control command group supported		
Serial Port RS-485	Comm port	1xbuilt-in and 2 more expandable on the left for Modbus/FreePort/N:N			
	Termination resistor	Built-in. PLC for master/slave application, 31 Modbus-RTU slaves max.			
CAN	NO	CANopen master with up to 31 slaves			
EtherNET	Port No.	1	2xEthernet ports with shared network board and IP address, network switching supported		
	Protocol	Modbus TCP master/slave for uploading/downloading and monitoring.16 slaves and 4 masters max at the same time. TCP free protocol for 4 connections			
Motion control	Positioning control command group, linear and circular interpolation, electronic gear, and electronic cam				
EtherCAT	Axis No.	8	16	32	48
	Slave No.	72 slaves max(including servo axes), real and visual axes 48 in total			
	Axis performance	Communication cycle in 250µs~8ms			

Programming Software

Self-developed Programming Software

# AUTO STUDIO Upgrade Non-stop



Oscilloscope



ST Language



Network Configuration



FB Function Block



Customized Function Block



Offline Simulation



# VH600 Series CODESYS-based Medium Controller



This is the first medium-sized PLC independently developed by VEICHI. Based on years of experience in the industrial control development and analysis of actual situations from various cases, this robust medium controller comes out specifically for high-end equipment and factory automation.

It provides users with ultra-high-speed computing and processing, excellent system performance, and a range of integrated functions. So, it is ideal for large-scale automation control of different processes, production lines and the whole factories.

Product Features

### Standard Development Platform

Full conformity to IEC61131-3 and PLCopen specification.  
Diversified programming languages (LD, FBD, ST, SFC, CFC)  
Customized function library encapsulation  
Integrated with rich motion control libraries, mathematical models, etc. for rapid development

### Multi-level Network

2xEtherNet (shared IP, built-in switch) 2xEtherCAT for up to 128 slaves.  
Sync cycle for 8 axes in 1ms, 16 axes in 2ms  
EtherNet/IP(master/slave)  
ModbusTCP(master/slave)  
3xRS485, each for 50 slaves 16xOPCUA client connection  
CANopen communication for 31 slaves

### Modular Free Configuration

16 modules expandable on the right  
Analog I/O, digital I/O, RS485, RCT clock optional on the left  
SD card for upgrade

### Fast and Precise Motion Control

8xhigh-speed counting input(200K) and 8xhigh-speed pulse output(200K)  
Complex control functions such as single-axis/multi-axis movement, interpolation, electronic cams and electronic gears, G-code, robots, etc.

## Standard Programming

- CODESYS-based programming in full conformity to IEC61131-3
- Diversified programming languages of ST, FBD, CFC, SFC and LD

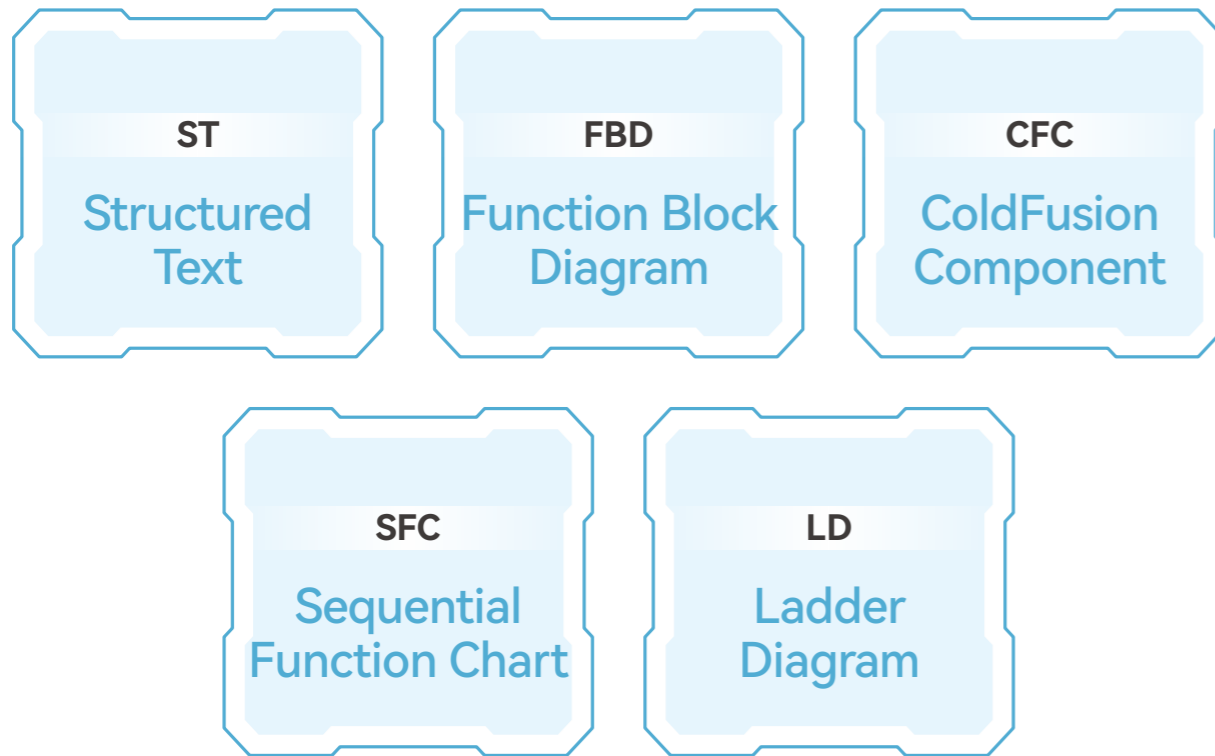

## Convenient Programming

- Online program modification, breakpoint tuning, and single-step cycle for enhanced efficiency
- Perfect error diagnosis function with TRACE function to monitor the movement track and locate the fault
- Powerful project management covering multi-task and multi-device download to deal with large-scale projects

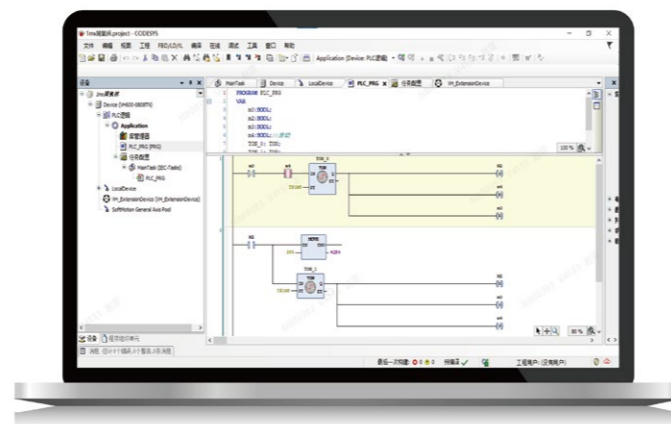

## Motion Control

- Multi-core processors assignment, Multicore 4 Cores supported
- Faster command processing and response, 8-axis sync cycle under bus control as fast as in 1ms.
- Single/multi-axis commands such as e-gear and e-cam Linear, circular, and axis combination interpolation
- Robot motion control, customized motion models, visualization functions, OPC UA functions, etc. available for complex and diverse scenarios

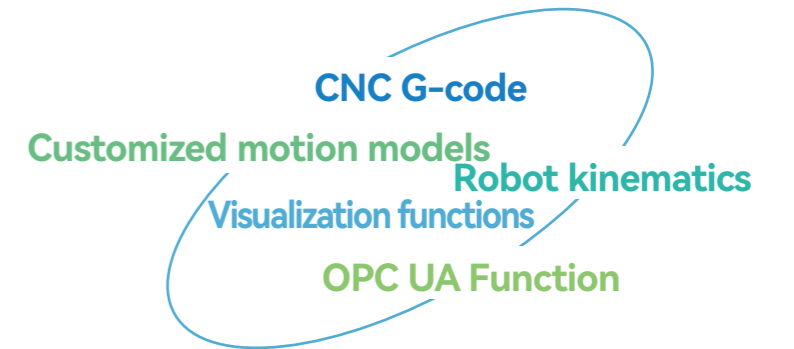

## Rich Motion Library

- Motion control libraries in conformity to PLCopen specifications
- User-defined encapsulation of function libraries and function blocks available
- Motion control libraries, robot libraries, customized kinematics and mathematical models integrated

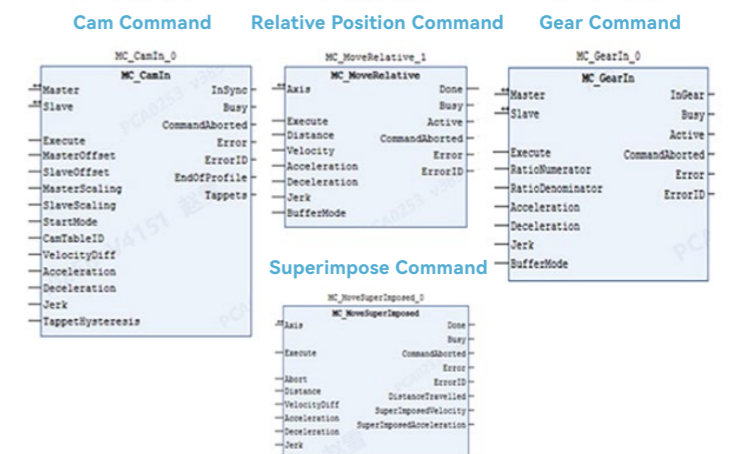

## Extensive Standard Industrial Network

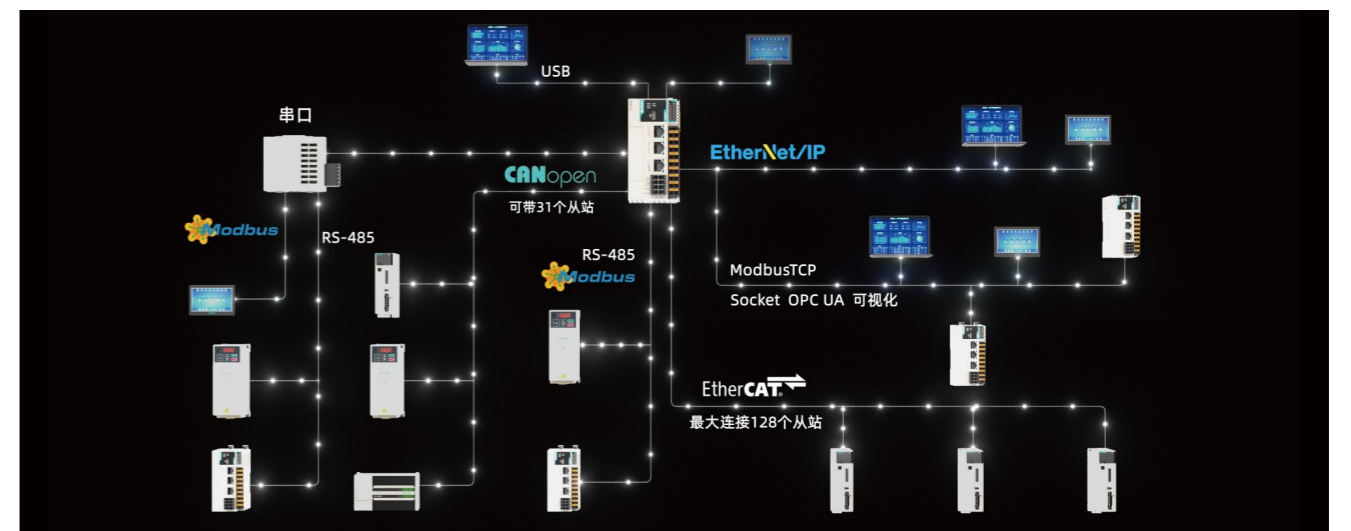

## VH600-0808TN Specifications

Item	Specification			
Model	VH600-0808TN/P	VH601-0808TN/P	VH602-0808TN/P	VH603-0808TN/P
Axis No.	128 axes max	8	16	32
Rated voltage	DC24V			
RS485	1×RS485			
CAN	CANopen master with up to 31 slaves			
EtherNet	2×EtherNet(built-in switch) for ModbusTCP, and program upload/download			
EtherCAT	128 EtherCAT slaves max. (including servo axes)			
High speed input	8×200K			
High speed output	8×200K, sourcing/sinking for option			
Left extension	2×RS485 expandable			
Right extension	16 max.			
SD card	1×32G SD card			
Data capacity	10MB for programs, and 512kB for power-down save (Flash), 20MB for data			
Language	LD, FBD, IL, ST, SFC, CFC in conformity to IEC 61131-3 Programming Language			
Motion control	Linear and circular interpolation, electronic gear, and electronic cam			



## VTC Series Temperature Controller



- A new-generation multi-channel high-precision temperature control product
- 8×high-speed, high-accuracy sampling and multi-loop PID regulation
- Suitable for various temperature control applications
- Compatible with thermocouples and RTDs for high measurement accuracy
- Integrated multi-channel digital output with rich functionality for user convenience

## Product Features

### Dedicated Debugging Software

Proprietary self-developed PC software for easy user configuration

### Multi-channel Temperature Control

Integrated multi-channel temperature control with centralized data management in the PC software

### Convenient Communication

Supports RS485 and USB communication, enabling seamless data exchange between the temperature controller and other devices or PC software

### Precision Control

Auto-tuning and multi-segment temperature setting functions ensure high-precision temperature control

## Naming Rules

VTC-08 08 T T

**VTC:**  
VTC series temperature controller

**Temperature Input**  
e.g., 8 input channels in the example

**Control Output**  
e.g., 8 output channels in the example

**Output Type**  
T: Transistor output

**Input Type**  
T: TC (Thermocouple) input  
P: PT (RTD) input  
M: Mixed input

## Specifications

Item		VTC-0408MT	VTC-0808TT
AI	Thermocouple	K, J, E, N, T, R, S, B	
	RTD	PT100, PT1000, Cu100, JPt100, Cu50, Ni120	NO
DO	Output type	8×NPN, loop supply voltage: 5V~24V; loop current: 0.3A/24VDC	
	Response time	<0.5ms	
Sampling cycle		Depends on valid input and control channels, min. 60ms, max. 400ms	
Control cycle		Depends on control object, min. 100ms	
Control mode		PID control, ON/OFF control, manual control	
Temperature measurement range		-200°C~1800°C	
	K-type	-120°C ~ 1360°C	
	J-type	-90°C ~ 1190°C	
	E-type	-70°C ~ 990°C	
	N-type	-200°C ~ 1290°C	
	T-type	-140°C ~ 390°C	
	R-type	-40°C ~ 1750°C	
	S-type	-40°C ~ 1750°C	
	B-type	60°C ~ 1800°C	
	Pt100	-190°C ~ 650°C	NO
	JPT100	-190°C ~ 650°C	NO
PT1000	-190°C ~ 300°C	NO	
Cu100	-40°C ~ 140°C	NO	
Cu50	-40°C ~ 140°C	NO	
Ni120	-60°C ~ 290°C	NO	
Accuracy	Thermocouple	±0.3% of full scale, ambient temperature compensation error ≤2°C	
	RTD	±0.5% of input range	NO
Isolation		Isolation between sampling channels and power supply and between sampling channels and outputs	

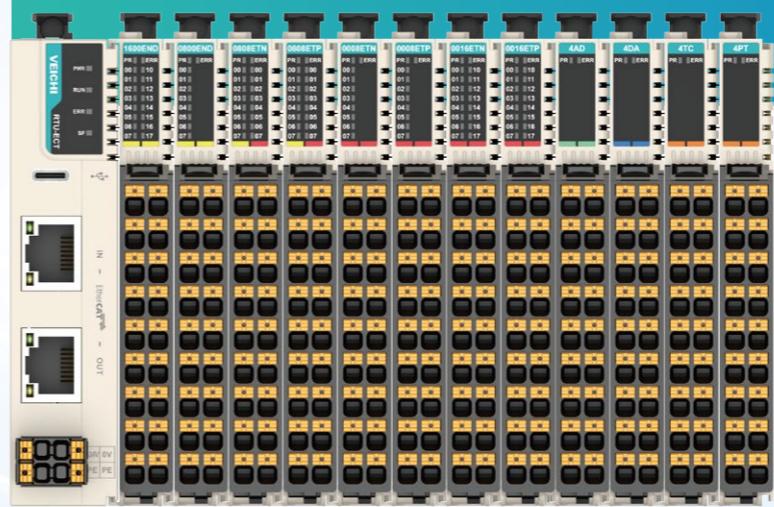

# VH Series

## Remote Extension Module

- Compact & lightweight design for easy integration
- Rapid signal processing with microsecond-level response
- Plug-and-Play installation and assembly
- Robust performance for harsh environments
- Optimized for standard fieldbus systems
- Modular design including communication interface module (master/host link) and extension modules (flexible I/O extension)
- Scalable configuration for lower wiring and hardware expenses
- Customizable setup of communication modules and extensions to site needs
- Distributed control ideal for decentralized automation with centralized management

Free Configuration

Stable Performance

Easy operation

## Product Features



16×modules max.



New generation of bus speeds up to **100Mbps**



Cabinet space reduced by **2/3**



**D-BUS design**  
Metal plate fitted on both sides for higher reliability

## VH-RTU-ECT (EtherCAT Communication)

Item	Specification
Extension No.	16 in total, including IO and special modules
Backplane bus	VBUS, VEICHI-defined
Backplane speed	100M
Transfer cycle	125 μs min.
Backplane bus compatibility	Remote modules compatible with local module communication protocols
Backplane communication	Daisy-chain fast-forwarding mode
EtherCAT port	IN: EtherCAT input OUT: EtherCAT output for EtherCAT slaves
Rated input voltage	24V DC (20.4V DC~ 28.8V DC)
Rated input current	0.6A (typical at 24V)
Power output derating	Derate 85% at 55°C
Isolation	24V not isolated from DO/DI, while DO/DI isolated from AO/AI
Power protection	Overcurrent protection, anti-reverse connection protection, and surge absorption
Input PDO No.	1024 bytes max.
Output PDO No.	1024 bytes max.
Input mailbox	256 bytes max.
Output mailbox	256 bytes max.
IO mapping	Three IO mapping methods: bit access, byte access, and word access
Stop output mode	Output according to fault stop mode and preset value, no more refresh

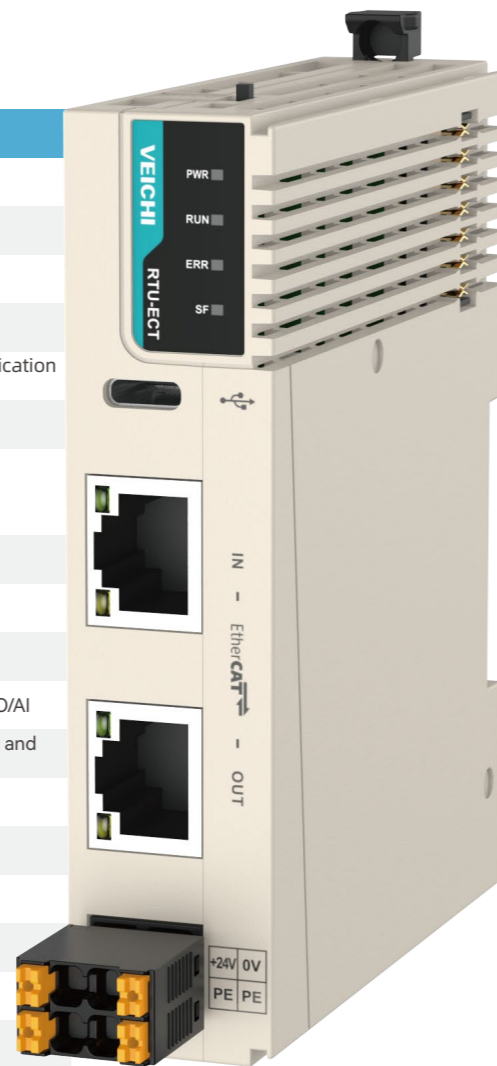

## VH-RTU-PN (PROFINET Communication)

Item	Specification
Communication mode	RT mode
Min.transfer cycle	1ms
I&M data	I&M0~I&M3
PROFINET version	V2.3
Extension No.	16 modules max.
PROFINET port	2
PROFINET switch	Networking supported
Physical layer	100BASE-TX
Traffic rate	100 Mbit/s (PROFINET)
Communication	Full duplex
Topology	Line, star, and tree type
Transmission medium	Cat5e and above
Transmission distance	<100m between two nodes
Prioritized startup	YES
Port disable	YES
Reconfiguration after replacem	NO(PN module of the same kind)
Factory reset	YES
Extension factory reset	NO
Firmware upgrade	YES



# VH-RTU-DP (PROFIBUS DP Communication)

Item	Specification
Physical layer	RS485
Communication rate	12 Mbit/s (PROFIBUS)
Communication mode	Half-duplex
Topology	Daisy-chain
Transmission medium	Shielded twisted pair
Transmission distance	< 100m between two nodes
Extension capacity	Up to 16 in total, including I/O modules and certain special modules
Backplane bus	VBUS (VEICHI-defined)
Backplane speed	100M
Backplane bus compatibility	Remote modules and local modules communication protocols compatible
Backplane communication mode	Daisy-chain fast-forwarding mode
PROFIBUS interface	DB9
I/O mapping	Bit access, byte access, and word access (three I/O mapping modes)





# VH Series Right Extension Module





- VH200, VH300, VH500, VH600 and VH series communication module compatibility
- 16×right extension modules addable for all
- New generation of bus speed up to 100Mbps

## Product Features

 Status diagnostics indicators for quick checks  
Colored plates for quick I/O function checks  
Clearly codes on wiring

 D-BUS connectors  
Corrosion-resistant connector materials  
Better stability than SMD design

 Removable terminals  
Convenient terminals for module replacement without rewiring

 Large terminal diameter for higher cable compatibility  
Push-in terminals for higher wiring efficiency

## DI Module Specifications

### VH-0800END 8×DI Modules

Item	Specification
Input method	NPN/PNP selectable via "S/S" terminal
Isolation	Comes with the module
Input voltage	24V DC
Input current	4mA(Typical)
Input impedance	6k(reference)
ON voltage	>15V DC
OFF voltage	<5V DC
Response time	1ms
Software filter time	(0~255)×0.25μs
Working temperature	-20°C~55°C
Module hot swap	NO

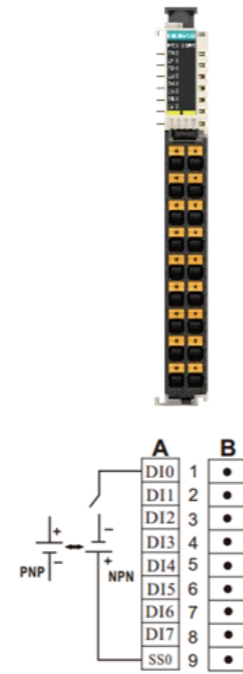

### VH-1600END 16×DI Modules

Item	Specification
Input method	NPN/PNP selectable via "S/S" terminal
Isolation	Comes with the module
Input voltage	24V DC
Input current	4mA(Typical)
Input impedance	6k(reference)
ON voltage	>15V DC
OFF voltage	<5V DC
Response time	1ms
Software filter time	(0~255)×0.25μs
Working temperature	-20°C~55°C
Module hot swap	NO

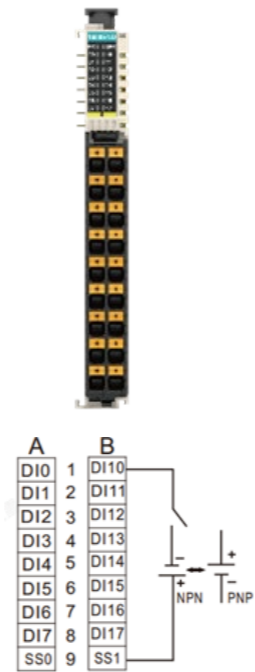

## DO Module Specifications

### VH-0008ETN 8×NPN DO Modules

Item	Specification
Output method	NPN transistor
Isolation	Comes with the module
Output voltage	24V DC
Output load (Resistance)	0.5A/terminal, 2A/module
Output load (Inductance)	7.2W/terminal, 12W/module
Output load (Lamp)	5W/terminal, 9W/module
Response time	100μs
Min. load	5Ma(5V~24V DC)
Working temperature	-20°C~55°C
Module hot swap	NO



### VH-0016ETN 16×NPN DO Modules

Item	Specification
Output method	NPN transistor
Isolation	Comes with the module
Output voltage	24V DC
Output load (Resistance)	0.5A/terminal, 2A/module
Output load (Inductance)	7.2W/terminal, 12W/module
Output load (Lamp)	5W/terminal, 9W/module
Response time	100μs
Min. load	5Ma(5V~24V DC)
Working temperature	-20°C~55°C
Module hot swap	NO



## DO Module Specifications

### VH-0008ETP 8×PNP DO Modules

Item	Specification
Output method	NPN transistor
Isolation	Comes with the module
Output voltage	24V DC
Output load (Resistance)	0.5A/terminal, 2A/module
Output load (Inductance)	7.2W/terminal, 12W/module
Output load (Lamp)	5W/terminal, 9W/module
Response time	100μs
Min. load	5Ma(5V~24V DC)
Working temperature	-20°C~55°C
Module hot swap	NO



### VH-0016ETP 16×PNP DO Modules

Item	Specification
Output method	NPN transistor
Isolation	Comes with the module
Output voltage	24V DC
Output load (Resistance)	0.5A/terminal, 2A/module
Output load (Inductance)	7.2W/terminal, 12W/module
Output load (Lamp)	5W/terminal, 9W/module
Response time	100μs
Min. load	5Ma(5V~24V DC)
Working temperature	-20°C~55°C
Module hot swap	NO



## DI/DO Module Specifications

### VH-0808ETN 8×NPN DI Modules, 8×NPN DO Modules

Item	Specification
Input method	NPN
Output method	NPN transistor
Isolation	Comes with the module
Input voltage	24V DC
Input current	4mA(Typical)
Output voltage	24V DC
Output load (Resistance)	0.5A/terminal, 2A/module
Working temperature	-20°C~55°C
Module hot swap	NO

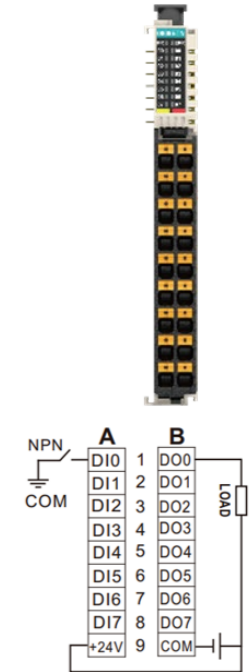

### VH-0808ETP 8×PNP DI Modules, 8×PNP DO Modules

Item	Specification
Input method	NPN
Output method	NPN transistor
Isolation	Comes with the module
Input voltage	24V DC
Input current	4mA(Typical)
Output voltage	24V DC
Output load (Resistance)	0.5A/terminal, 2A/module
Working temperature	-20°C~55°C
Module hot swap	NO

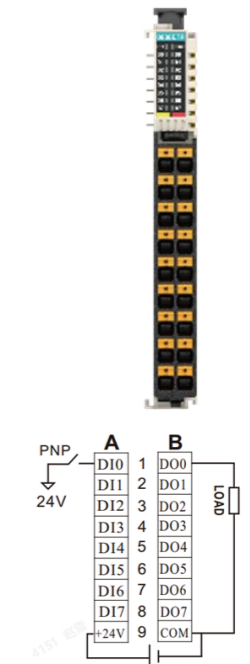

## AI Module Specifications

### VH-4AD 4×AI Modules

Item	Specification
Input type	AI
Isolation	Communication between analog and digital circuits isolated by capacitors; 24V DC power input to the analog circuit module isolated internally; No isolation between analog channels
Input method	Voltage/current
Input channel	4
Resolution	16-bit
Switching time	60μs/channel
Voltage range	±10V
Input impedance	1MΩ
Voltage accuracy (25°C)	±0.1% (full-scale)
Voltage limit	±12V
Current range	20mA, 0mA~20mA, 4mA~20mA
Current sampling impedance	250Ω
Current accuracy (25°C)	±0.1% (full-scale)
Current limit	±30mA(Instantaneous),±24mA(average)
Working temperature	-20°C~55°C
Bus input rated current	120mA (typical at 5V DC)
Module hot swap	NO

## AO Module Specifications

### VH-4DA 4×AO Modules

Item	Specification
Output type	AO
Isolation	Communication between analog and digital circuits isolated by capacitors; 24V DC power input to the analog circuit module isolated internally; No isolation between analog channels
Output method	Voltage/current
Output channel	4
Resolution	12-bit
Switching time	250μs/channel
Voltage range	±10V
Voltage Output Impedance	1KΩ
Voltage accuracy (25°C)	±1% (full-scale)
Voltage diagnosis	No short-circuit detection
Current range	0mA~20mA, 4mA~20mA
Current load	0Ω~600Ω
Current accuracy (25°C)	±1% (full-scale)
Current diagnosis	No open-circuit detection
Bus input rated current	80mA (typical at 5V DC)
Module hot swap	NO

## Temperature/Weight Detection Module

### VH-4PT 4×RTD Input Modules

Item	Specification			
	Celsius (°C)		Fahrenheit (°F)	
Input signal	PT100, PT500, PT1000, Cu50, Cu100, KTY84, NTC5K, NTC10K, 4 channels in total			
Resolution	24-bit			
Slew rate	(15±2%) ms × 4 channels (unused channels not converted)			
Rated temperature	PT100/500/1000	-150.0°C ~ 600.0°C	PT100/500/1000	-238.0°F ~ 1112.0°F
	Cu100/Cu50	-30°C ~ 120°C	Cu100/Cu50	-22°F ~ 248°F
	KTY84	0.0°C ~ 200.0°C	KTY84	32.0°F ~ 392.0°F
	NTC5K/10K	-30.0°C/-25°C ~ +200.0°C	NTC5K/10K	-22.0°F/-13°F ~ 392.0°F
Sensitivity	0.1°C		0.1°F	
Accuracy (25°C)	Full scale*±0.1%			
Accuracy (-20°C~+55°C)	Full scale*±0.3%			
Isolation	Communication between analog and digital circuits isolated by capacitors Internal isolation between analog circuit and module 24V DC power ; No isolation between analog channels			
Bus power rated voltage	5V DC (4.75V~5.25V DC)			
Bus power rated current	120mA (Typical at 5V DC)			
Module hot swap	NO			

### VH-2WT 2×Weighting Modules

Item	Specification
Channel No.	2
Isolation	Unified Isolation (No isolation between channels)
Resolution	24-bit
Digital range	32-bit
Conversion speed	1ms, 3ms, or 6ms(Configurable per channel)
Bridge measurement (Rated)	±39mV
Reference measurement (Rated)	5V
Sensor sensitivity	0V/V~6mV/V
Load capacity	40 Ω~4010 Ω
Calibration method	Manual calibration, copy calibration parameters
Hardware filter	Low-pass filter (below 10 kHz)
Software filter	Power frequency filter, moving average filter
Weighing accuracy	0.01%

### VH-4TC 4×Thermocouple Input Modules

Item	Specification			
	Celsius (°C)		Fahrenheit (°F)	
I/O occupancy	No			
Input signal	Thermocouples: Types K, J, E, B, N, T, R, S for channels, 4 channels in total			
Resolution	24-bit			
Slew rate	(240±2%)ms × 4 channels (unused channels not converted)			
Compensation method	Cold junction compensation			
Rated temperature	Type K	-100°C ~ 1200°C	Type K	-148°F ~ 2192°F
	Type J	-100°C ~ 1000°C	Type J	-148°F ~ 1832°F
	Type E	-100.0°C ~ 1000°C	Type E	-148°F ~ 1832°F
	Type B	200°C ~ 1800°C	Type B	392°F ~ 3272.°F
	Type N	-100°C ~ 1200°C	Type N	-148°F ~ 2192°F
	Type T	-200°C ~ 400°C	Type T	-328°F ~ 752°F
	Type R	0°C ~ 1600°C	Type R	32°F ~ 2912°F
	Type S	0°C ~ 1600°C	Type S	32°F ~ 2912°F
Sensitivity	0.1°C		0.1°F	
Accuracy (25°C)	(±0.1%) (±100mV full scale) + cold junction compensation error			
Accuracy (-20°C~+55°C)	(±0.3%) (±100mV full scale) + cold junction compensation error			
Isolation	Communication between analog and digital circuits isolated by capacitors DC/DC isolation between the analog circuit power supply and the 24Vdc power supply			
Bus power rated voltage	5V DC (4.75V~5.25V DC)			
Bus power rated current	120mA (Typical at 5V DC)			
Module hot swap	NO			

Note: With appropriate mode settings, both °C and °F data can be obtained.

# VH Series Left Extension Module

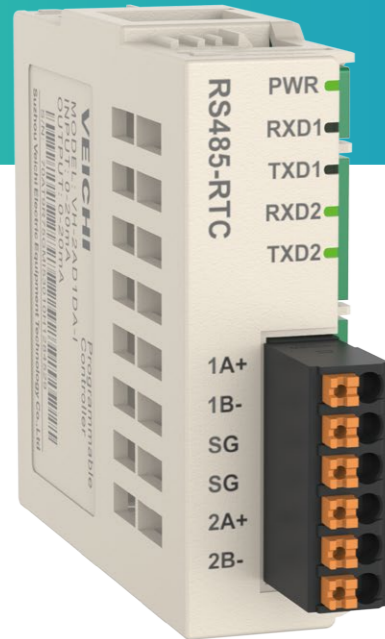

VH300, VH500, VH600 Series  
One expansion board to the left for all

## VH-2AD1DA-V/I-(RTC)

Item	Input	Output
Channel No.	2	1
Voltage range	0V ~ 10V	
Current range	0mA ~ 20mA	
Voltage input impedance/output load	> 200kΩ	> 2kΩ
Current sampling impedance/output load	250Ω	<500Ω
Slew rate	2ms/channel	
Input accuracy (25°C)	Voltage ±1%, current ±1% (full-scale)	±1% (full-scale)
Input accuracy (full temperature scale)	Voltage ±3%, current ±3% (full-scale)	±5% (full-scale)
Resolution	12bit	
Digital Output	0 ~ 10000	



## VH-RS485(-RTC)

Item	Specification	
RS485	Channel No.	2
	Isolation	YES
	Termination resistor	Controlled by a dip switch, connected by default
	Slave No.	Up to 31 slaves (VH600 for 50 slaves), the distance between each slave <3m.
	Baud rate	9.6 kbit/s, 19.2 kbit/s, 38.4 kbit/s, 57.6 kbit/s, 115.2 kbit/s
	Distance	<100m for 115.2kbit/s <1000m for 19.2kbit/s

## VH-4DI-(RTC)

Item	Specification	
Input type	DI	
Input channel	4	
Input method	Sourcing and sinking	
Input voltage level	24V DC±10% (21.6V~26.4V DC)	
Common input	Current when input ON	> 2.5mA
	Current when input OFF	< 1mA
	Response time	≈10ms(RC filter time)
	Input impedance	6kΩ
ON voltage	≥15V DC	
OFF voltage	≤5V DC	
Software filter time	NO	
Isolation	Optocoupler isolated	
Public terminal	One public terminal shared by 4 inputs (Input power supply polarity +/- changeable)	
Input display	Indicator ON during input (controlled by hardware)	



## VH-4DO-TN-(RTC)

Item	Specification	
Output type	Digital transistor low side output	
Output channel	4	
Voltage level	24V DC (21.6V DC~26.4V DC)	
Common output	Output load (Resistance)	0.5A/terminal, 1A/Public terminal
	Output load (Inductance)	6W/24V DC
	Output load (Lamp)	1W/24V DC
	Hardware response time ON/ OFF	≤100μs (OFF→ON and ON→OFF)
	Load current	≥5mA
	Max. output frequency	Resistance load 100Hz, inductance load 0.5Hz, lamp load 10Hz
OFF leakage current	<50μA	
Max. ON residual voltage	<0.5V DC	
Isolation	Optocoupler isolated	
Public terminal	One public terminal shared by 4 inputs(Output power -)	
Surge suppressor	Zener diode	
Short circuit protection	NO	
Output display	Indicator ON during output (controlled by hardware)	

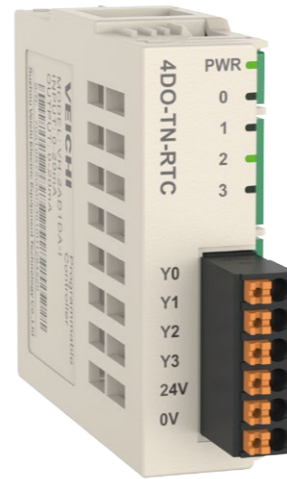

## VH Series Main Module Models

Type	Model	Input	Output	Type-C	Serial Port	CANopen	Ethernet	EtherCAT	
General	VH600-0808TN	8×200kHz	8×NPN(200kHz)	Program download	1×RS485, expandable on left	Master	Dual	128 axes max.	
	VH600-0808TP	8×200kHz	8×PNP(200kHz)	Program download	1×RS485, expandable on left	Master	Dual	128 axes max.	
	VH601-0808TN	8×200kHz	8×NPN(200kHz)	Program download	1×RS485, expandable on left	Master	Dual	8 axes max.	
	VH601-0808TP	8×200kHz	8×PNP(200kHz)	Program download	1×RS485, expandable on left	Master	Dual	8 axes max.	
	Medium-sized PLC	VH602-0808TN	8×200kHz	8×NPN(200kHz)	Program download	1×RS485, expandable on left	Master	Dual	16 axes max.
		VH602-0808TP	8×200kHz	8×PNP(200kHz)	Program download	1×RS485, expandable on left	Master	Dual	16 axes max.
VH603-0808TN		8×200kHz	8×NPN(200kHz)	Program download	1×RS485, expandable on left	Master	Dual	32 axes max.	
VH603-0808TP		8×200kHz	8×PNP(200kHz)	Program download	1×RS485, expandable on left	Master	Dual	32 axes max.	
Motion Control PLC	VH524-0808TN	8×200kHz	8×NPN(200kHz)	Program download	1×RS485, expandable on left	Master	Dual	48 axes max.	
	VH524-0808TP	8×200kHz	8×PNP(200kHz)	Program download	1×RS485, expandable on left	Master	Dual	48 axes max.	
	VH523-0808TN	8×200kHz	8×NPN(200kHz)	Program download	1×RS485, expandable on left	Master	Dual	32 axes max.	
	VH523-0808TP	8×200kHz	8×PNP(200kHz)	Program download	1×RS485, expandable on left	Master	Dual	32 axes max.	
High-performance PLC	VH522-0808TN	8×200kHz	8×NPN(200kHz)	Program download	1×RS485, expandable on left	Master	Dual	16 axes max.	
	VH522-0808TP	8×200kHz	8×PNP(200kHz)	Program download	1×RS485, expandable on left	Master	Dual	16 axes max.	
	VH511-0808TN	8×200kHz	8×NPN(200kHz)	Program download	1×RS485, expandable on left	NO	Single	8 axes max.	
	VH511-0808TP	8×200kHz	8×PNP(200kHz)	Program download	1×RS485, expandable on left	NO	Single	8 axes max.	
General PLC	VH311-0808TN	8×200kHz	8×NPN(200kHz)	Program download	1×RS485, expandable on left	Master	Single	NO	
	VH311-0808TP	8×200kHz	8×PNP(200kHz)	Program download	1×RS485, expandable on left	Master	Single	NO	
	VH301-0808TN	8×200kHz	8×NPN(200kHz)	Program download	1×RS485, expandable on left	NO	NO	NO	
	VH301-0808TP	8×200kHz	8×PNP(200kHz)	Program download	1×RS485, expandable on left	NO	NO	NO	
Economic PLC	VH210-0808TN1	2×50kHz, 6×Medium-speed,1×AD	4×NPN(100kHz),1×DA	Program download	1×RS485, 1×RS232	NO	Single	NO	
	VH210-0808TP1	2×50kHz, 6×Medium-speed,1×AD	4×NPN(100kHz),1×DA	Program download	1×RS485, 1×RS232	NO	Single	NO	
Economic PLC	VH210-0808TN	2×50kHz, 6×Medium-speed	4×NPN(100kHz)	Program download	1×RS485, 1×RS232	NO	Single	NO	
	VH210-0808TP	2×50kHz, 6×Medium-speed	4×PNP(100kHz)	Program download	1×RS485, 1×RS232	NO	Single	NO	
Temperature Controller	VH100-0808TN	2×50kHz, 6×Medium-speed	3×NPN(100kHz)	Program download	1×RS485, 1×RS232	NO	NO	NO	
	VH100-0808TP	2×50kHz, 6×Medium-speed	3×PNP(100kHz)	Program download	1×RS485, 1×RS232	NO	NO	NO	
Remote Communication	VTC-0408MT	4×PT/TC	8×NPN	Program download	1×RS485	NO	NO	NO	
	VTC-0808TT	8×TC	8×NPN	Program download	1×RS485	NO	NO	NO	
	VH-RTU-ECT	EtherCAT remote communication interface modules		Message reading	NO	NO	NO	Slave	
Remote Communication	VH-RTU-PN	PROFINET remote communication interface modules		Message reading	NO	NO	NO	NO	
	VH-RTU-DP	Profibus DP remote communication interface modules		Message reading	NO	NO	NO	NO	

## VH-RTC

Item	Specification
Communication	I <sup>2</sup> C
Clock accuracy	120 seconds/month
Clock format	Year-Month-Day Hour-Minute-Second
Battery	CR2354-corded coin cell battery, 5 years life, replaceable



### Left Extension Models

Model	Specification
VH-RS485-1	1×RS485
VH-RS485	2×RS485
VH-RS485-RTC-1	1×RS485 + Real-Time Clock (RTC)
VH-RS485-RTC	2×RS485 + Real-Time Clock (RTC)
VH-ADI	4×DI
VH-ADI-RTC	4×DI + Real-Time Clock (RTC)
VH-ADO-TN-RTC	4×Sinking Digital Output + Real-Time Clock (RTC)
VH-2AD1DA-I	2×AI, 1×AO(Current Type)
VH-2AD1DA-I-RTC	2×AI, 1×AO (Current Type) + RTC
VH-2AD1DA-V	2×AI, 1×AO (Voltage Type)
VH-2AD1DA-V-RTC	2×AI, 1×AO (Voltage Type) + RTC
VH-RTC	Real-Time Clock Extension Board

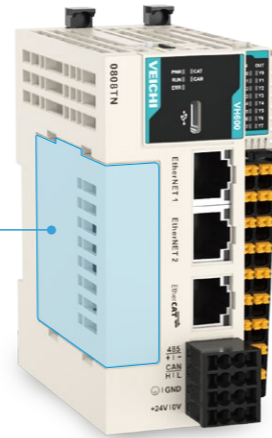

### Installation Dimensions(mm)

VH100/200/VTC

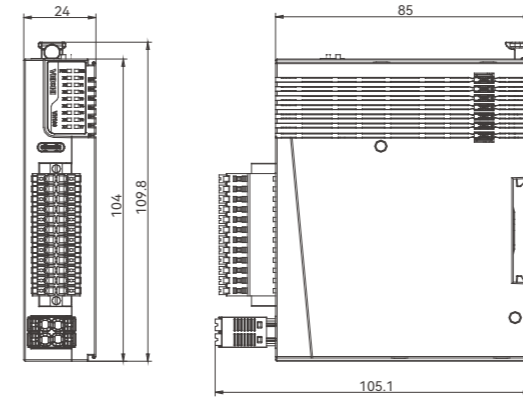

VH-RTU

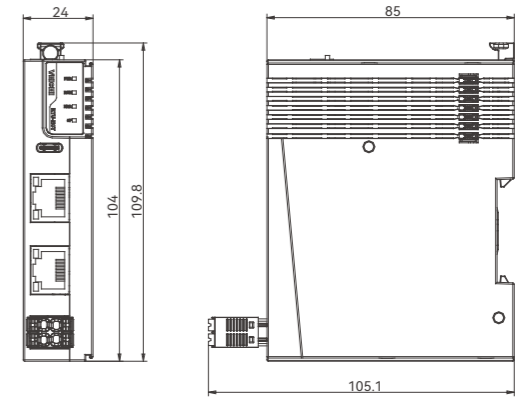

VH300/500/600

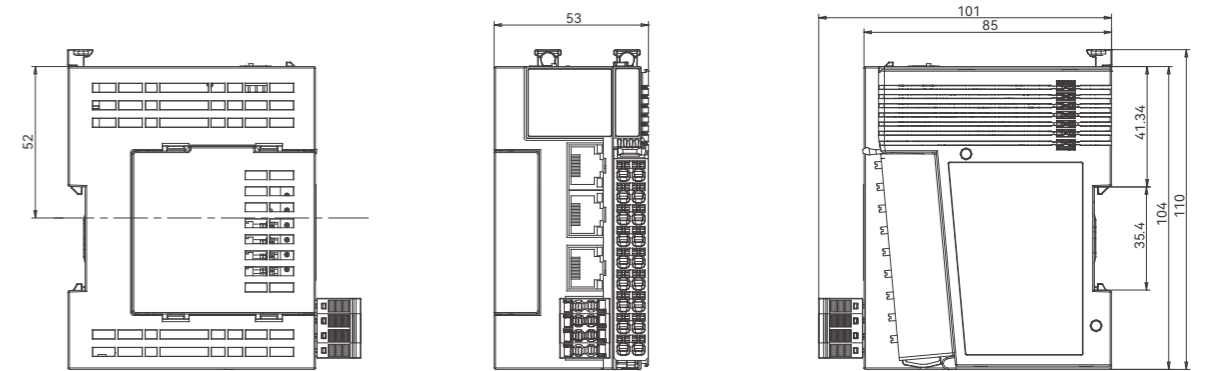

### Right Extension Models

Model	Specification
VH-1600END	16×DI
VH-0800END	8×DI
VH-0016ETN	16×NPN DO
VH-0016ETP	16×PNP DO
VH-0808ETN	8×DI+ 8×NPN DO
VH-0808ETP	8×DI+ 8×PNP DO
VH-0008ETN	8×NPN DO
VH-0008ETP	8×PNP DO
VH-4AD	4×AI
VH-4DA	4×AO
VH-4DA2	4×AO (0.1% Accuracy)
VH-4PT	4×RTD (Resistance Temperature Detector) Input
VH-4TC	4×Thermocouple Input
VH-2WT	2×Weighing Input

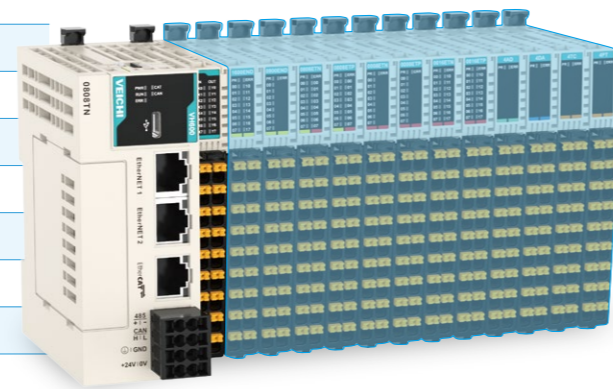

VH Right Extension

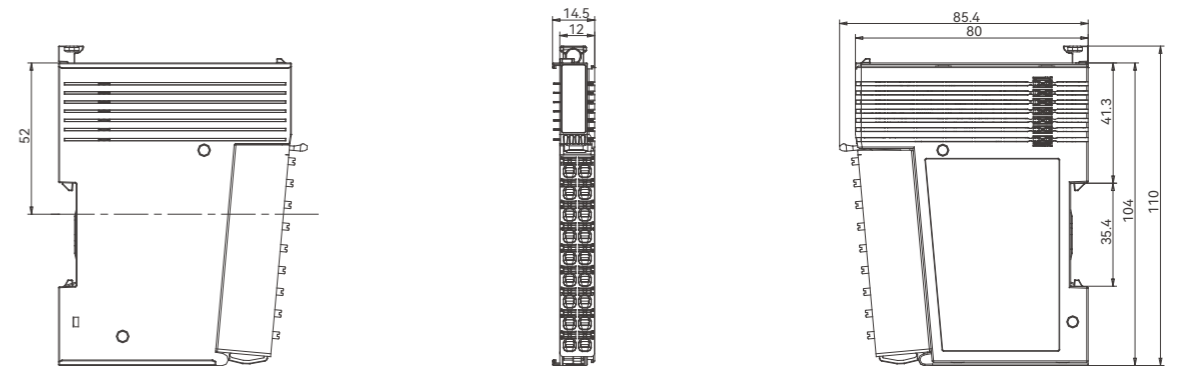

## Research and Production

### R&D and Technology Platform

- Consolidating a dynamic force of top-tier professionals and technical experts in domestic industrial control, our R&D team represents 37.16% of our workforce, with 74.62% of our technical staff boasting bachelor's degrees or higher.
- Guided by philosophy of "Innovate with technology and strive for excellence," VEICHI is deeply customer-centric by providing stable and reliable products and technologies designed to the evolving needs of our clients.
- Investing 10% of our revenue into R&D, VEICHI has crafted advanced labs for EMC, safety, reliability, and performance testing to ensure product quality.
- In-depth cooperation with many famous universities and research institutions in China has been established and "Jiangsu Postdoctoral Innovation Practice Base" and "Jiangsu Postgraduate Workstation" are set up successively.

### Intelligent Automation

- Digitally driven from inception to production, VEICHI boasts an annual capacity of 914,600 units with streamlined efficiency.
- 5 imported SMT placement lines, 5 automated coating lines, 4 DIP test lines, a robotic arm-equipped automated line, and 12 production lines are equipped with the latest intelligent manufacturing tools.
- All of the product checks are carried out automatically by the management mode of 3 (tri-inspection system)+ 1 (proportional inspection) during the whole process for standard performance.
- Three major production management system WMS, MES and ERP together ensure that the unique code of each product is traceable in the system to manage product quality.



## Service and Support

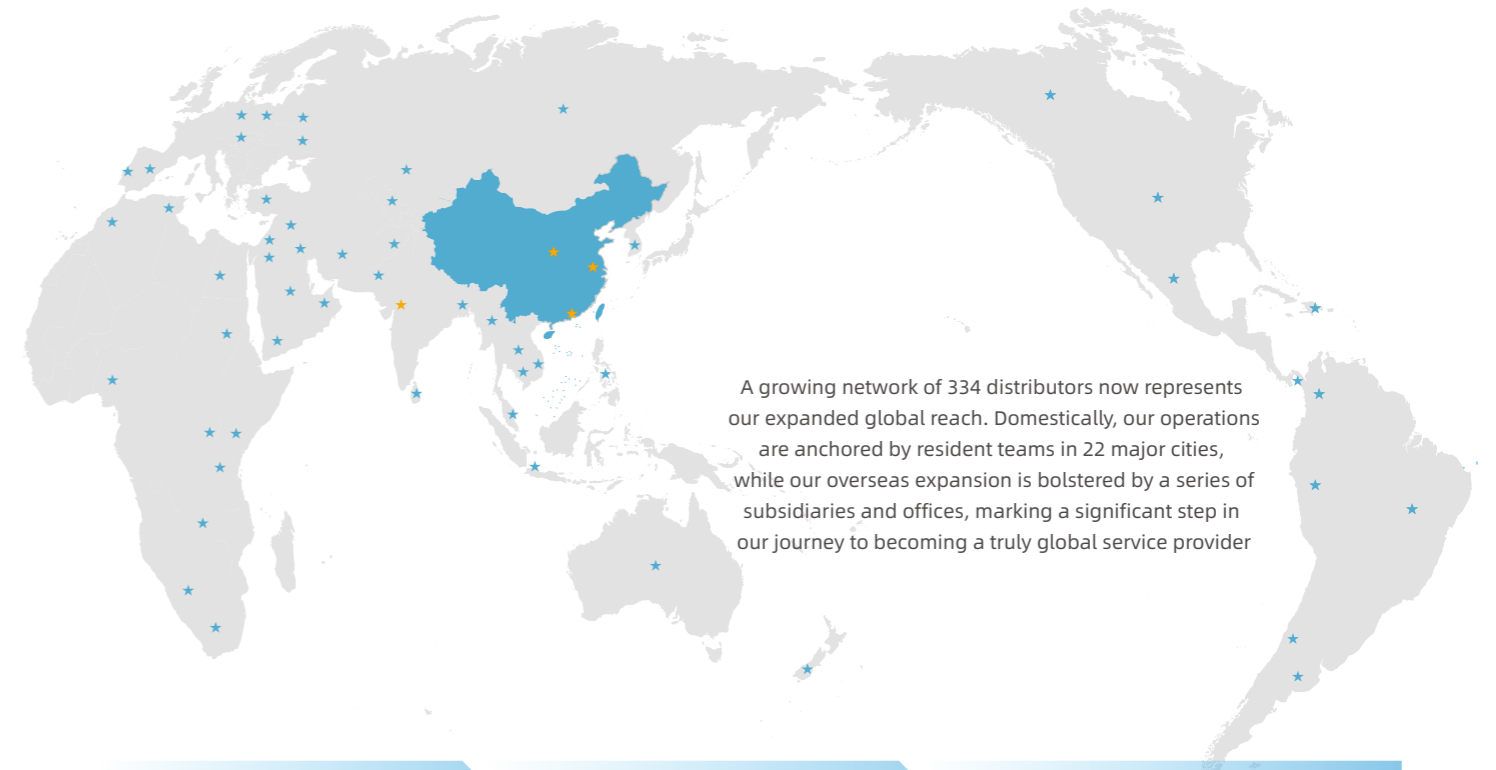

A growing network of 334 distributors now represents our expanded global reach. Domestically, our operations are anchored by resident teams in 22 major cities, while our overseas expansion is bolstered by a series of subsidiaries and offices, marking a significant step in our journey to becoming a truly global service provider

### 01 Pre-sales

Technology promotion, site survey and energy efficiency assessment

### 02 In-sales

Customization, design consultation, installation and commissioning, and site training

### 03 Post-sales

Regular return visits, timely maintenance and repair and user training

