

**mitsubishi**  
PROGRAMMABLE CONTROLLERS  
MELSEC-F

Art.no. 133192  
2001 05 15  
JY992D89301-F

# HARDWARE MANUAL

FX1N SERIES PROGRAMMABLE CONTROLLERS



# FX1N

## Foreword

- This manual contains text, diagrams and explanations which will guide the reader in the correct installation and operation of the FX1N Series Programmable Controllers. It should be read and understood before attempting to install or use the unit.
- Further information can be found in the FX Series Programming Manual II.
- If in doubt at any stage of the installation of an FX1N Series Programmable Controller always consult a professional electrical engineer who is qualified and trained to the local and national standards which apply to the installation site.
- If in doubt about the operation or use of FX1N Series Programmable Controller please consult the nearest Mitsubishi Electric distributor.
- This manual is subject to change without notice.



# FX<sub>1</sub>N Series Programmable Controllers

## Hardware Manual

Manual number : JY992D89301

Manual revision : F

Date : April 2001

## **Guidelines for the safety of the user and protection of the FX<sub>1N</sub>.**

This manual provides information for the installation and use of the FX<sub>1N</sub>. The manual has been written to be used by trained and competent personnel. The definition of such a person or persons is as follows;

- a) Any engineer who is responsible for the planning, design and construction of automatic equipment using the product associated with this manual should be of a competent nature, (trained and qualified to the local and national standards required to fulfill that role). These engineers should be fully aware of all aspects of safety with regards to automated equipment.
- b) Any commissioning or service engineer must be of a competent nature, trained and qualified to the local and national standards required to fulfill that job. These engineers should also be trained in the use and maintenance of the completed product. This includes being completely familiar with all associated documentation for the said product. All maintenance should be carried out in accordance with established safety practices.
- c) All operators of the completed product should be trained to use that product in a safe and co-ordinated manner in compliance to established safety practices. The operators should also be familiar with documentation which is connected with the actual operation of the completed equipment.

**Note** : The term ‘completed equipment’ refers to a third party constructed device which contains or uses the product associated with this manual.

## Note's on the symbols used in this manual

At various times through out this manual certain symbols will be used to highlight points of information which are intended to ensure the users personal safety and protect the integrity of the equipment. Whenever any of the following symbols are encountered, its associated note must be read and understood. Each of the symbols used will now be listed with a brief description of its meaning.

### Hardware warnings



1) Indicates that the identified danger **WILL** cause physical and property damage.



2) Indicates that the identified danger could **POSSIBLY** cause physical and property damage.



3) Indicates a point of further interest or further explanation.

### Software warning



4) Indicates special care must be taken when using this element of software.



5) Indicates a special point which the user of the associate software element should be aware of.



6) Indicates a point of interest or further explanation.

- Under no circumstances will Mitsubishi Electric be liable or responsible for any consequential damage that may arise as a result of the installation or use of this equipment.
- All examples and diagrams shown in this manual are intended only as an aid to understanding the text, not to guarantee operation. Mitsubishi Electric will accept no responsibility for actual use of the product based on these illustrative examples.
- Owing to the very great variety in possible application of this equipment, you must satisfy yourself as to its suitability for your specific application.

### Associated Manuals

The following manuals are recommended as essential reference material for the correct operation of a FX<sub>1N</sub> series Programmable controller.

Manual Name	Manual Number	Description
FX Programming Manual II	JY992D88101	Programming manual for FX1S, FX1N, FX2N and FX2NC series Programmable Logic Controllers
FX1N-422-BD Users	JY992D84101	Instruction regarding the RS422 interface board
FX1N-485-BD Users	JY992D84201	Instruction regarding the RS485 interface board
FX1N-232-BD Users	JY992D84401	Instruction regarding the RS232 interface board
FX1N-8AV-BD	JY992D84601	Instruction regarding the variable potentiometer input board
FX1N-CNV-BD	JY992D84701	Instruction regarding the special adapter board
FX1N-5DM Users	JY992D84901	Instruction regarding the display module 5DM
FX1N-4EX-BD Users	JY992D95001	Instruction regarding the special input board
FX1N-2EYT-BD Users	JY992D95201	Instruction regarding the special output board
FX1N-2AD-BD Users	JY992D96201	Instruction regarding the special AD conversion board
FX1N-1DA-BD Users	JY992D96401	Instruction regarding the special DA conversion board

# Table of Contents

Guideline .....	ii
1. Introduction.....	1-1
1.1 World Specification.....	1-6
1.2 Model Name .....	1-7
1.3 Serial Numbers .....	1-8
1.4 Configuration .....	1-9
1.4.1 Input/Output Points and Current Consumption .....	1-11
1.4.2 Rules of Expansion .....	1-13
1.5 Back up Data .....	1-14
1.5.1 EEPROM backup .....	1-14
1.5.2 Capacitor backup .....	1-14
2. Terminal layouts .....	2-1
2.1 AC Powered Main Units .....	2-1
2.2 DC Powered Main Units .....	2-4
2.3 FX2N and FX0N Extension blocks .....	2-7

3. Installation Notes .....	3-1
3.1 Product Outline .....	3-2
3.2 FX1N RUN/STOP Control .....	3-4
3.3 General Specifications .....	3-5
3.4 PLC Mounting Arrangements .....	3-6
3.5 DIN Rail Mounting .....	3-7
3.6 Direct Mounting .....	3-8
3.7 Termination at Screw Terminals .....	3-10
3.8 Wiring Techniques .....	3-11
3.9 Installing Optional Units .....	3-12
3.9.1 Special Function Boards .....	3-12
3.9.2 FX1N-5DM Display Module .....	3-14
4. Power Supply .....	4-1
4.1 Wiring Techniques .....	4-1
4.2 Wiring Cautions .....	4-1
4.3 Power Supply .....	4-1
4.4 Power Requirements .....	4-2
4.5 Example Wiring .....	4-3
4.5.1 AC Power supply .....	4-3
4.5.2 DC Power supply .....	4-4
4.6 Service Power supply .....	4-6
4.7 Earthing / Grounding .....	4-6

5. Inputs.....	5-1
5.1 24V DC input Specifications .....	5-1
5.1.1 Typical Wiring .....	5-2
5.1.2 Input Circuit Connection .....	5-3
5.1.3 Diodes and Inputs Connected in Series .....	5-4
5.1.4 Resistors and Inputs Connected in Parallel .....	5-5
5.2 AC110V Input Extension Block.....	5-6
5.2.1 Input Circuit Connection .....	5-6
5.2.2 Programming Caution .....	5-7
6. Outputs.....	6-1
6.1 Output Specifications.....	6-1
6.1.1 Relay Output Example .....	6-2
6.1.2 Reliability Tests .....	6-3
6.1.3 Response Times .....	6-3
6.1.4 Transistor Output Example.....	6-4
6.1.5 Japanese Model Transistor Output .....	6-4
6.2 Applying Safe Loads.....	6-5

7. Diagnostics .....	7-1
7.1 Preliminary Checks.....	7-1
7.2 ERROR LED ON (CPU ERROR) .....	7-2
7.3 Common Errors .....	7-3
7.4 Maintenance .....	7-3
7.5 Operation and Error Flags .....	7-4
7.6 PLC Status Registers .....	7-5
7.7 Error Registers .....	7-6
7.8 Error Codes .....	7-7
7.9 Instruction List .....	7-8
7.10 Device List .....	7-11

<b>1</b>	<b>INTRODUCTION</b>
<b>2</b>	<b>TERMINAL LAYOUTS</b>
<b>3</b>	<b>INSTALLATION NOTES</b>
<b>4</b>	<b>POWER SUPPLY</b>
<b>5</b>	<b>INPUTS</b>
<b>6</b>	<b>OUTPUTS</b>
<b>7</b>	<b>DIAGNOSTICS</b>



# 1. Introduction

This manual covers hardware installation instructions for the FX<sub>1N</sub> Series PLC.

MODEL	INPUT		OUTPUT		POWER SUPPLY	DIMENSIONS mm (inches)			WEIGHT kg (lbs)			
	QTY	TYPE	QTY	TYPE								
FX1N-14MR-ES/UL	8	24V DC Sink/ Source	6 (8)	Relay	100-240 VAC +10% -15% 50/60Hz	90 (3.6)	90 (3.5)	75 (3.0)	0.45 (0.99)			
FX1N-14MT-ESS/UL				Transistor						90 (3.6)	0.45 (0.99)	
FX1N-24MR-ES/UL	14 (16)		10 (16)	Relay		130 (5.2)			0.65 (1.44)			
FX1N-24MT-ESS/UL				Transistor						175 (7.0)	0.80 (1.77)	
FX1N-40MR-ES/UL	24		16	Relay		12V DC -15% to 24V DC +20%			90 (3.6)			90 (3.5)
FX1N-40MT-ESS/UL				Transistor						130 (5.2)	0.65 (1.44)	
FX1N-60MR-ES/UL	36 (40)		24	Relay					175 (7.0)			
FX1N-60MT-ESS/UL				Transistor						90 (3.6)	0.45 (0.99)	
FX1N-14MR-DS	8	24V DC Sink/ Source	6 (8)	Relay	12V DC -15% to 24V DC +20%		90 (3.6)	90 (3.5)	75 (3.0)			
FX1N-14MT-DSS				Transistor						90 (3.6)	0.45 (0.99)	
FX1N-24MR-DS	14 (16)		10 (16)	Relay			130 (5.2)					
FX1N-24MT-DSS				Transistor						175 (7.0)	0.80 (1.77)	
FX1N-40MR-DS	24		16	Relay		12V DC -15% to 24V DC +20%	90 (3.6)					90 (3.5)
FX1N-40MT-DSS				Transistor						130 (5.2)	0.65 (1.44)	
FX1N-60MR-DS	36 (40)		24	Relay			175 (7.0)					
FX1N-60MT-DSS				Transistor						90 (3.6)	0.45 (0.99)	

Note: Occupied points are shown in brackets for input and outputs.

Main unit outline

UNITS: mm (inches)

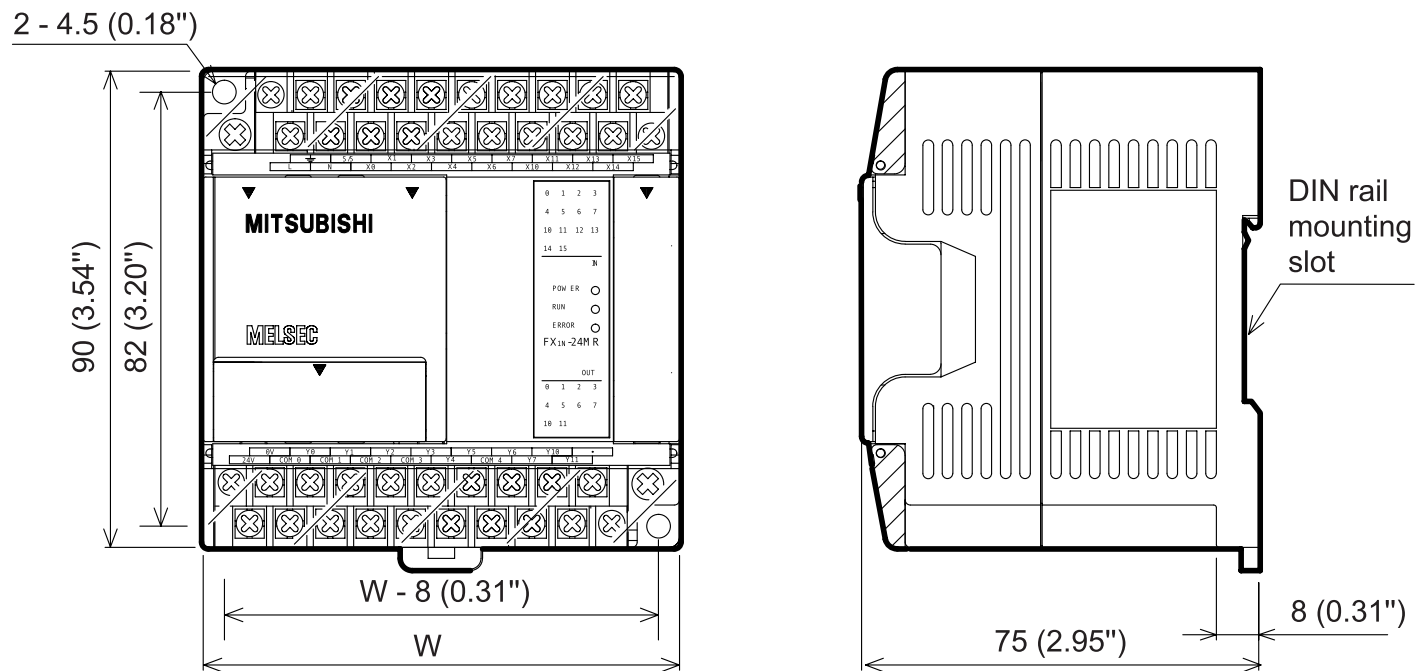

Please see the previous page for each units width measurement.

## Powered Extension units

MODEL	INPUT		OUTPUT		POWER SUPPLY	DIMENSIONS mm (inches)			WEIGHT kg (lbs)
	QTY	TYPE	QTY	DEVICE					
FX0N-40ER-ES/UL	24	24V DC Sink/ Source	16	Relay	100- 240VAC +10%, -15% 50/60Hz	150 (5.9)	90 (3.5)	87 (3.4)	0.75 (1.65)
FX0N-40ET-DSS	24		16	Transistor (Source)	24VDC +20% -15%				
FX0N-40ER-DS	24		16	Relay					
FX2N-32ER-ES/UL	16		16	Relay	100- 240VAC +10%, -15% 50/60Hz	150 (5.9)			0.65 (1.4)
FX2N-32ET-ESS/UL	16		16	Transistor (Source)					
FX2N-48ER-ES/UL	24		24	Relay		182 (7.2)			0.85 (1.9)
FX2N-48ET-ESS/UL	24		24	Transistor (Source)	100- 240VAC +10%, -15% 50/60Hz				
FX2N-48ER-UA1/UL	24		110VAC	24	Relay				220 (8.7)

## Extension blocks

MODEL	INPUT		OUTPUT			DIMENSIONS mm (inches)			MASS (WEIGHT) kg (lbs)
	QTY	TYPE	QTY	DEVICE	TYPE				
FX0N-8EX-UA1/UL	8	110V AC inputs	-	-	-	43 (1.7)	90 (3.5)	87 (3.4)	0.2 (0.44)
FX0N-8EX-ES/UL	8	24V DC Sink/ Source	-	-	-				
FX0N-8ER-ES/UL	4		4	Relay	-				
FX0N-8EYR-ES/UL	-	-	8		-				
FX0N-8EYT-ESS/UL	-	-	8	Transistor	Source				
FX0N-16EX-ES/UL	16	24V DC Sink/ Source	-	-	-	70 (2.8)			0.3 (0.66)
FX0N-16EYR-ES/UL	-	-	16	Relay	-				
FX0N-16EYT-ESS/UL	-	-	16	Transistor	Source				
FX2N-16EX-ES/UL	16	24V DC Sink/ Source	-	-	-	40 (1.6)	90 (3.5)	87 (3.4)	0.3 (0.66)
FX2N-16EYR-ES/UL	-	-	16	Relay	-				
FX2N-16EYT-ESS/UL	-	-	16	Transistor	Source				

## Special function blocks

MODEL	DESCRIPTION	NUMBER OF I/O			POWER SUPPLY		DIMENSIONS mm (inches)			MASS (WEIGHT) kg (lbs)
		I	O		Internal 5V DC	External 24V DC				
FX2N-2DA	Digital to analog converter	-	8	-	30mA	85mA*1	43 (1.7)		87 (3.4)	0.2(0.44)
FX2N-2AD	Analog to digital converter	-	8	-	20mA	50mA*1				
FX2N-4DA	Digital to analog converter	-	8	-	30mA	200mA	55 (2.1)		87 (3.4)	0.3(0.66)
FX2N-4AD	Analog to digital converter	-	8	-	30mA	55mA				
FX2N-4AD-PT	PT 100 probe interface	-	8	-	30mA	50mA				
FX2N-4AD-TC	Thermo-couple interface	-	8	-	30mA	50mA	90 (3.5)		87 (3.4)	0.2(0.44)
FX2N-32CCL	CC-Link Interface block	-	8	-	130mA	50mA				
FX2N-16LNK-M	MELSEC-I/O LINK Remote I/O system master block	*2	8	*2	200mA	90mA	43 (1.7)			0.5(1.1)
FX0N-3A	Analog / Digital converter	-	8	-	30mA	90mA*1	43 (1.7)		87 (3.4)	0.2(0.44)
FX2N-8AD	Analog input block	-	8	-	50mA	80mA	75 (3.0)		75 (3.0)	0.3(0.66)

\*1: Internal 24V DC

\*2: The value depends on the switch setting.

## Special Function Boards

MODEL	DESCRIPTION	NUMBER OF I/O			DIMENSIONS
		I	O		
FX1N-4EX-BD	Four point special input	-	0	-	Mounts directly into top of PLC
FX1N-2EYT-BD	Two point special output	-	0	-	
FX1N-2AD-BD	Two channel special analog to digital converter	-	0	-	
FX1N-1DA-BD	One channel special digital to analog converter	-	0	-	

### 1.1 World Specification.

<b>Input Sink / Source</b>	World spec models : SINK / SOURCE. Japanese models : ALWAYS SINK.
<b>Outputs Transistor</b>	World spec models : ALWAYS SOURCE. Japanese models : ALWAYS SINK.

## 1.2 Model Name

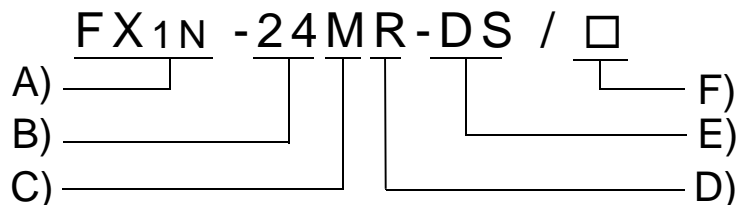

### Notes on model name

<b>A)</b>	PLC type : FX1N
<b>B)</b>	Total number of I / O channels
<b>Unit type</b>	
<b>C)</b>	M MPU - main unit
	E Powered extension unit
	EX Extension block, input
	EY Extension block, output
<b>Output type</b>	
<b>D)</b>	R Relay
	T Transistor
	S Triac (SSR)

		Features
<b>E)</b>	Omit	AC, Japanese spec.
	D	DC Japanese spec.
	DS	DC World spec, CE & UL registered *1.
	DSS	DC World spec. DC source transistor, CE & UL registered *1.
	E	AC, Japanese spec.
	ES	AC, World spec, CE registered.
	ESS	AC World spec. DC source transistor, CE registered.
	UA1	AC Power Supply, AC inputs, CE registered. *2
	<b>F)</b>	UL

### Note:

- \*1. World spec FX<sub>1</sub>N DC type main units have not yet received official UL certification.
- \*1. FX<sub>0</sub>N series extension units do not have UL certification.
- \*2. FX<sub>0</sub>N series extension units do not have CE certification.

### 1.3 Serial Numbers

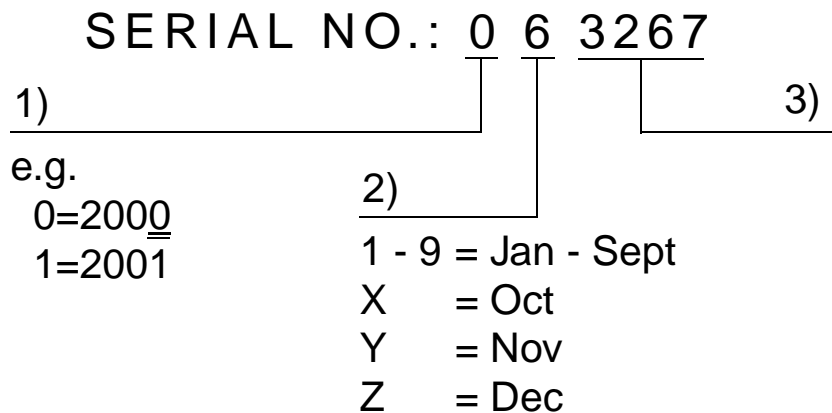

#### Notes on serial numbers

1)	Production year
2)	Production month
3)	Production serial number

# 1.4 Configuration

## Schematic system

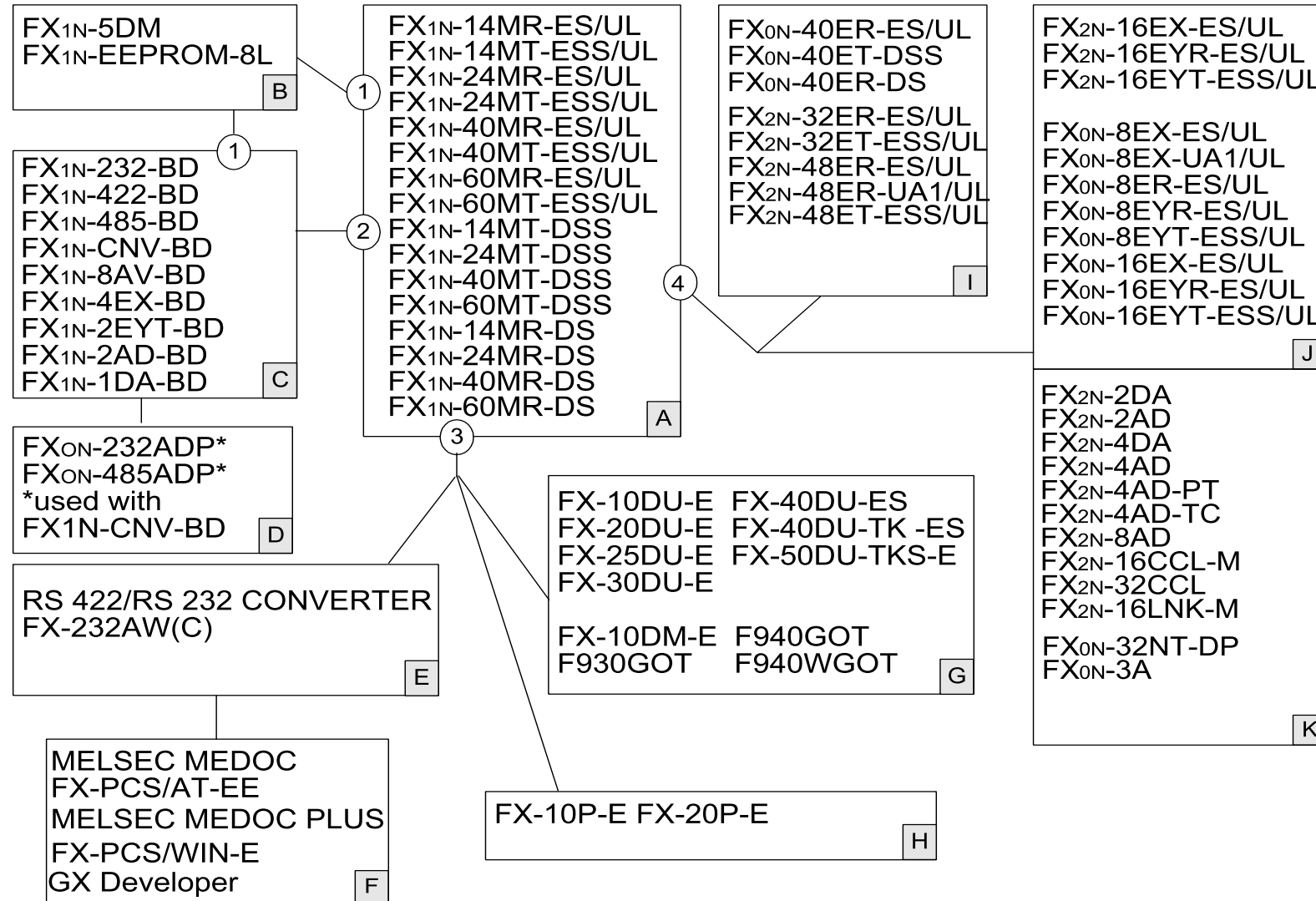

**Configuration notes**

<b>A</b>	MPU-Main unit (Main Processing Unit)
<b>B</b>	FX1N Memory cassette or Display Module
<b>C</b>	FX1N Expansion boards
<b>D</b>	FX0N Network adapters
<b>E</b>	Programming cables
<b>F</b>	Programming software
<b>G</b>	HMI devices, F900GOT, FX-DU Series
<b>H</b>	Dedicated programming tools
<b>I</b>	Powered extension units
<b>J</b>	Extension blocks
<b>K</b>	Special function blocks

①	Memory port
②	Extension board port
③	Programming port
④	MPU bus port

### 1.4.1 Input/Output Points and Current Consumption

The following tables show the input/output points of various types of FX series extension blocks, and special function blocks, along with the special function block current consumption.

#### Extension blocks

MODEL	INPUT X	OUTPUT Y	TOTAL
FX0N-8ER-ES/UL	4(8)	4(8)	16*1
FX0N-8EX-ES/UL	8	-	8
FX0N-8EX-UA1/UL	8	-	8
FX0N-8EYR-ES/UL	-	8	8
FX0N-8EYT-ESS/UL	-	8	8
FX0N-16EX-ES/UL	16	-	16
FX0N-16EYT-ESS/UL	-	16	16
FX0N-16EYR-ES/UL	-	16	16
FX2N-16EX-ES/UL	16	-	16
FX2N-16EYR-ES/UL	-	16	16
FX2N-16EYT-ESS/UL	-	16	16

\*1:8 points are used for actual input/output, however, this block should occupy 16 input/output points.

**Special function block    Function adapters**

MODEL	CURRENT CONSUMPTION 5V DC	INPUT X	OUTPUT Y		TOTAL
			X/Y		
FX0N-3A	30mA	-	8	-	8
FX0N-32NT-DP	170mA	-	8	-	8
FX2N-2AD	20mA	-	8	-	8
FX2N-4AD	30mA	-	8	-	8
FX2N-4AD-PT	30mA	-	8	-	8
FX2N-4AD-TC	30mA	-	8	-	8
FX2N-2DA	30mA	-	8	-	8
FX2N-4DA	30mA	-	8	-	8
FX2N-8AD	50mA		8		8
FX2N-16CCL-M	Self supplied		8		8
FX2N-32CCL	130mA	-	8	-	8
FX2N-16LNK-M	200mA	*2	8	*2	*2
FX0N-232ADP	200mA	-	-	-	-
FX0N-485ADP	30mA	-	-	-	-

\*2: The value depends on the switch setting.

### 1.4.2 Rules of Expansion

The FX<sub>1N</sub> Series can be expanded by 2 special function blocks or upto 32 points of I/O when used on its own. It can also be expanded by 4 special function blocks when used in conjunction with an FX<sub>0N</sub> extension unit (2+2). An AC powered FX<sub>1N</sub> can be expanded by 8 special function blocks when used in conjunction with an FX<sub>2N</sub> extension unit (2+6).

The maximum for an FX<sub>1N</sub> system is 128 points of I/O and 8 special function blocks

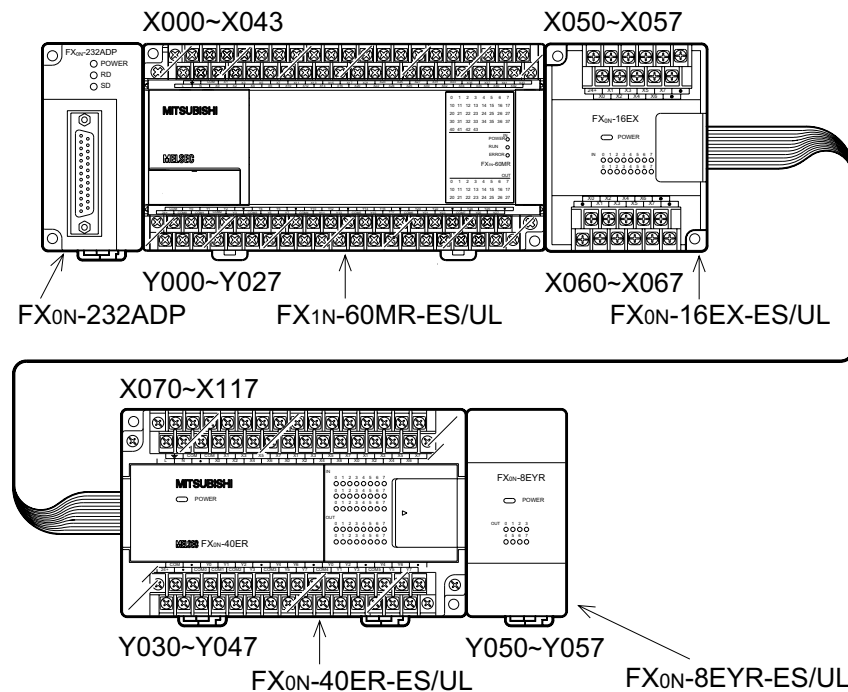

If a DC powered main unit is being used with a power supply of less than 24VDC - 15% (20.4V DC or less) it **cannot** be expanded by using special function blocks or extension units. It can however accomodate a maximum additional 32 points of I/O.

If an FX<sub>1N</sub> Special function board is being used, it does not alter the rules for expansion outlined above, as it utilizes special M coils for its operation and therefore does not contribute to the maximum 128 I/O point count. Only one special function board can be used at any time. See section 3.9.1 for more details.

## 1.5 Back up Data

### 1.5.1 EEPROM backup

Data includes the Program, Comment, File Registers (D1000 ~ D7999), and parameter data. This will be stored as long as the EEPROM is not damaged.

If the PLC has been powered up for five minutes or more, the following data will be saved in the EEPROM at powerdown:

S10 ~ S127, M384 ~ M511, C16 ~ C31, and D128 ~ D255.

### 1.5.2 Capacitor backup

The capacitor backed memory includes M512 ~ M1535, S128 ~ S999, T240 ~ T255, C32 ~ C199, C220 ~ C234, and D256 ~ D7999 and the RTC.

The capacitor backed memory will retain programs for a maximum of 10 days, and requires 30 minutes to recharge upon power up.

**Note:** The FX<sub>1N</sub> does not have battery backup, if a system requires backup of more than 10 days, a peripheral backup power source must be provided.

<b>1</b>	<b>INTRODUCTION</b>
<b>2</b>	<b>TERMINAL LAYOUTS</b>
<b>3</b>	<b>INSTALLATION NOTES</b>
<b>4</b>	<b>POWER SUPPLY</b>
<b>5</b>	<b>INPUTS</b>
<b>6</b>	<b>OUTPUTS</b>
<b>7</b>	<b>DIAGNOSTICS</b>



## 2. Terminal layouts

The following selection of terminal layouts are taken from the FX<sub>1N</sub> product range.

Note: All layouts are diagrammatic and are only intended to aid the creation of wiring diagrams.

### 2.1 AC Powered Main Units

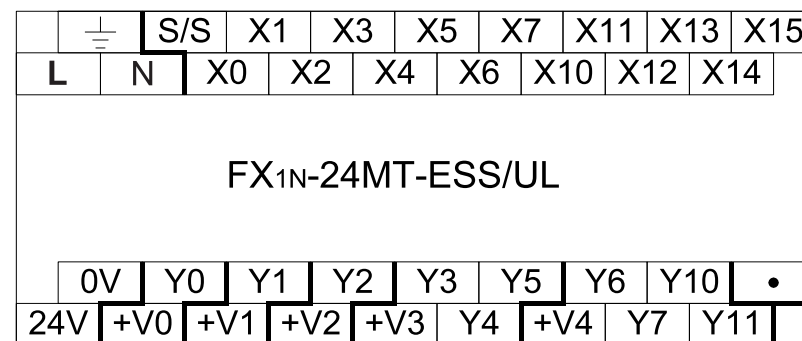
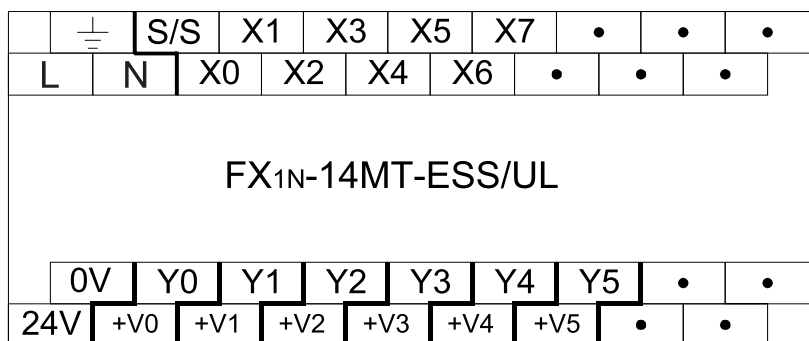
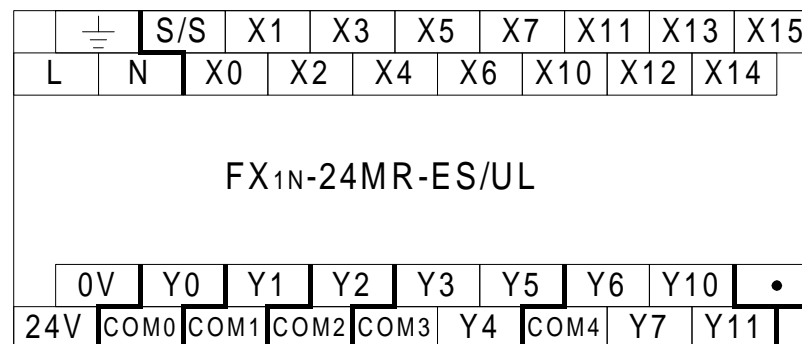
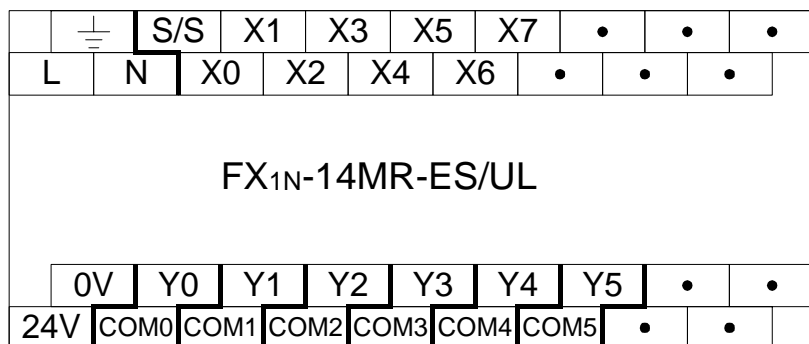

	⏏	S/S	X1	X3	X5	X7	X11	X13	X15	X17	X21	X23	X25	X27
L	N	X0	X2	X4	X6	X10	X12	X14	X16	X20	X22	X24	X26	
FX <sub>1N</sub> -40MR-ES/UL														
	0V	Y0	Y1	Y2	•	Y4	Y6	•	Y10	Y12	•	Y14	Y16	•
24V	COM0	COM1	COM2	Y3	COM3	Y5	Y7	COM4	Y11	Y13	COM5	Y15	Y17	

	⏏	S/S	X1	X3	X5	X7	X11	X13	X15	X17	X21	X23	X25	X27
L	N	X0	X2	X4	X6	X10	X12	X14	X16	X20	X22	X24	X26	
FX <sub>1N</sub> -40MT-ESS/UL														
	0V	Y0	Y1	Y2	•	Y4	Y6	•	Y10	Y12	•	Y14	Y16	•
24V	+V0	+V1	+V2	Y3	+V3	Y5	Y7	+V4	Y11	Y13	+V5	Y15	Y17	

	$\perp$	S/S	X1	X3	X5	X7	X11	X13	X15	X17	X21	X23	X25	X27	X31	X33	X35	X37	X41	X43
L	N	X0	X2	X4	X6	X10	X12	X14	X16	X20	X22	X24	X26	X30	X32	X34	X36	X40	X42	
FX <sub>1N</sub> -60MR-ES/UL																				
	0V	Y0	Y1	Y2	•	Y4	Y6	•	Y10	Y12	•	Y14	Y16	•	Y20	Y22	•	Y24	Y26	•
24V	COM0	COM1	COM2	Y3	COM3	Y5	Y7	COM4	Y11	Y13	COM5	Y15	Y17	COM6	Y21	Y23	COM7	Y25	Y27	

	$\perp$	S/S	X1	X3	X5	X7	X11	X13	X15	X17	X21	X23	X25	X27	X31	X33	X35	X37	X41	X43
L	N	X0	X2	X4	X6	X10	X12	X14	X16	X20	X22	X24	X26	X30	X32	X34	X36	X40	X42	
FX <sub>1N</sub> -60MT-ESS/UL																				
	0V	Y0	Y1	Y2	•	Y4	Y6	•	Y10	Y12	•	Y14	Y16	•	Y20	Y22	•	Y24	Y26	•
24V	+V0	+V1	+V2	Y3	+V3	Y5	Y7	+V4	Y11	Y13	+V5	Y15	Y17	+V6	Y21	Y23	+V7	Y25	Y27	

## 2.2 DC Powered Main Units

	⊥	S/S	X1	X3	X5	X7	•	•	•
⊕	⊖	X0	X2	X4	X6	•	•	•	
FX <sub>1N</sub> -14MR-DS									
	0V	Y0	Y1	Y2	Y3	Y4	Y5	•	•
24V	COM0	COM1	COM2	COM3	COM4	COM5	•	•	

	⊥	S/S	X1	X3	X5	X7	X11	X13	X15
⊕	⊖	X0	X2	X4	X6	X10	X12	X14	
FX <sub>1N</sub> -24MR-DS									
	0V	Y0	Y1	Y2	Y3	Y5	Y6	Y10	•
24V	COM0	COM1	COM2	COM3	Y4	COM4	Y7	Y11	

	⊥	S/S	X1	X3	X5	X7	•	•	•
⊕	⊖	X0	X2	X4	X6	•	•	•	
FX <sub>1N</sub> -14MT-DSS									
	0V	Y0	Y1	Y2	Y3	Y4	Y5	•	•
24V	+V0	+V1	+V2	+V3	+V4	+V5	•	•	

	⊥	S/S	X1	X3	X5	X7	X11	X13	X15
⊕	⊖	X0	X2	X4	X6	X10	X12	X14	
FX <sub>1N</sub> -24MT-DSS									
	0V	Y0	Y1	Y2	Y3	Y5	Y6	Y10	•
24V	+V0	+V1	+V2	+V3	Y4	+V4	Y7	Y11	

	⊥	S/S	X1	X3	X5	X7	X11	X13	X15	X17	X21	X23	X25	X27
⊕	⊖	X0	X2	X4	X6	X10	X12	X14	X16	X20	X22	X24	X26	
FX <sub>1N</sub> -40MR-DS														
	0V	Y0	Y1	Y2	•	Y4	Y6	•	Y10	Y12	•	Y14	Y16	•
24V	COM0	COM1	COM2	Y3	COM3	Y5	Y7	COM4	Y11	Y13	COM5	Y15	Y17	

	⊥	S/S	X1	X3	X5	X7	X11	X13	X15	X17	X21	X23	X25	X27
⊕	⊖	X0	X2	X4	X6	X10	X12	X14	X16	X20	X22	X24	X26	
FX <sub>1N</sub> -40MT-DSS														
	0V	Y0	Y1	Y2	•	Y4	Y6	•	Y10	Y12	•	Y14	Y16	•
24V	+V0	+V1	+V2	Y3	+V3	Y5	Y7	+V4	Y11	Y13	+V5	Y15	Y17	

	$\perp$	S/S	X1	X3	X5	X7	X11	X13	X15	X17	X21	X23	X25	X27	X31	X33	X35	X37	X41	X43
⊕	⊖	X0	X2	X4	X6	X10	X12	X14	X16	X20	X22	X24	X26	X30	X32	X34	X36	X40	X42	
FX <sub>1N</sub> -60MR-DS																				
	0V	Y0	Y1	Y2	•	Y4	Y6	•	Y10	Y12	•	Y14	Y16	•	Y20	Y22	•	Y24	Y26	•
24V	COM0	COM1	COM2	Y3	COM3	Y5	Y7	COM4	Y11	Y13	COM5	Y15	Y17	COM6	Y21	Y23	COM7	Y25	Y27	

	$\perp$	S/S	X1	X3	X5	X7	X11	X13	X15	X17	X21	X23	X25	X27	X31	X33	X35	X37	X41	X43
⊕	⊖	X0	X2	X4	X6	X10	X12	X14	X16	X20	X22	X24	X26	X30	X32	X34	X36	X40	X42	
FX <sub>1N</sub> -60MT-DSS																				
	0V	Y0	Y1	Y2	•	Y4	Y6	•	Y10	Y12	•	Y14	Y16	•	Y20	Y22	•	Y24	Y26	•
24V	+V0	+V1	+V2	Y3	+V3	Y5	Y7	+V4	Y11	Y13	+V5	Y15	Y17	+V6	Y21	Y23	+V7	Y25	Y27	



# MEMO

<b>1</b>	<b>INTRODUCTION</b>
<b>2</b>	<b>TERMINAL LAYOUTS</b>
<b>3</b>	<b>INSTALLATION NOTES</b>
<b>4</b>	<b>POWER SUPPLY</b>
<b>5</b>	<b>INPUTS</b>
<b>6</b>	<b>OUTPUTS</b>
<b>7</b>	<b>DIAGNOSTICS</b>



### **3. Installation Notes**

The installation of FX<sub>1N</sub> products has been designed to be safe and easy. When the products associated with this manual are used as a system or individually, they must be installed in a suitable enclosure. The enclosure should be selected and installed in accordance to the local and national standards.

### 3.1 Product Outline

#### Features of the FX<sub>1N</sub> PLC

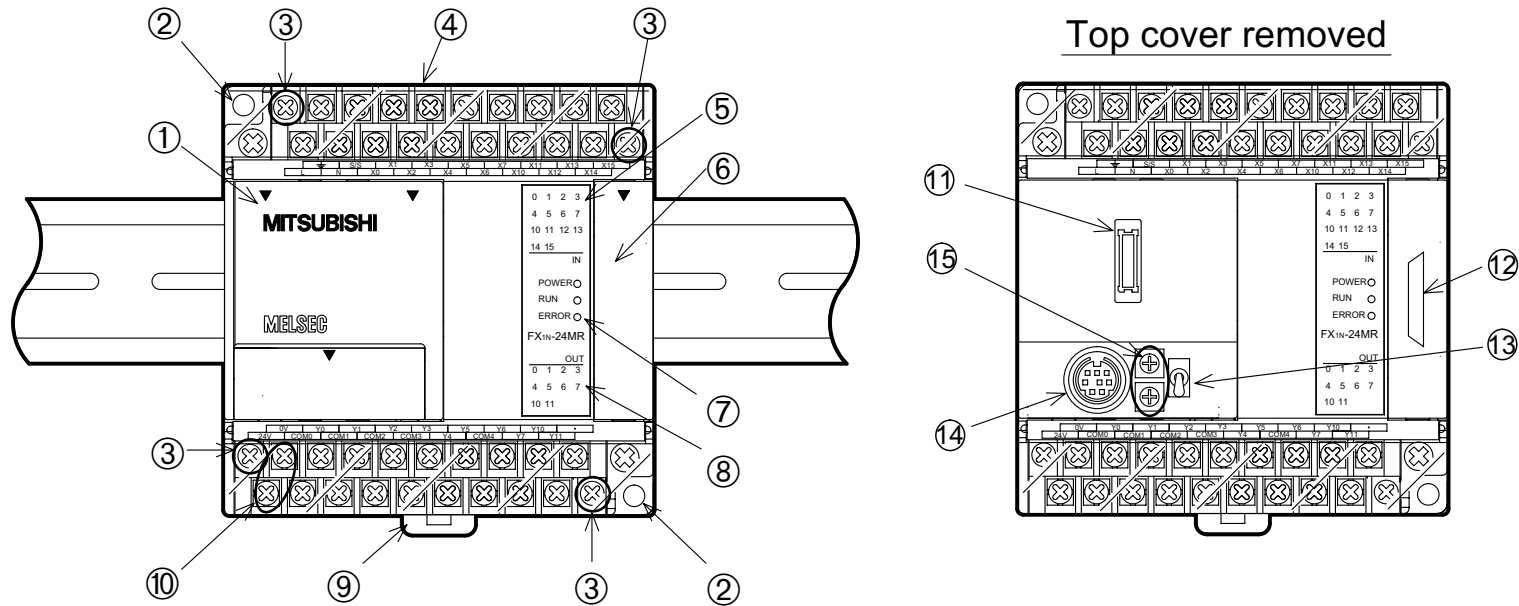

**Features table**

<b>1</b>	Top cover
<b>2</b>	Direct mounting holes (4.5 mm diameter)
<b>3</b>	I/O terminal block securing screws
<b>4</b>	Input terminals (24V DC) and power supply terminals
<b>5</b>	Input LED status indicators
<b>6</b>	Expansion port cover
<b>7</b>	PLC status indicators (POWER, RUN, ERROR)
<b>8</b>	Output LED status indicators
<b>9</b>	DIN rail mounting clip
<b>10</b>	Output terminals and power supply source terminals
<b>11</b>	Optional equipment connector
<b>12</b>	Expansion port
<b>13</b>	Run/Stop switch
<b>14</b>	Programming port
<b>15</b>	Variable analog potentiometers. Upper pot, D8030 read from VR1. Lower pot D8031 read from VR2

### 3.2 FX<sub>1N</sub> RUN/STOP Control

RUN or STOP of the FX<sub>1N</sub> can be controlled by:

- ❶ The RUN/STOP switch mounted next to the programming port.
- ❷ A standard input (X0 to X17) defined by the system parameters.
- ❸ Remotely from a personal computer or other programming peripheral.



**Note:** The FX<sub>1N</sub> RUN/STOP switch works in parallel with the RUN-input terminal. Please refer to the table below.

During remote operation the FX<sub>1N</sub> RUN/STOP status is determined by the most recently operated control.

E.g. If the RUN/STOP switch is in RUN and a remote STOP is made from a personal computer the RUN/STOP switch must be switched to STOP then back to RUN to switch the MPU back to RUN mode.

#### Run input terminal

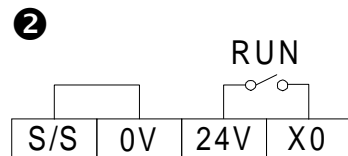

#### RUN/STOP selection

❶ RUN/STOP SWITCH	❷ RUN INPUT TERMINAL	FX <sub>1N</sub> MPU STATUS
✓	✓	RUN
✓	x	RUN
x	x	STOP
x	✓	RUN

### 3.3 General Specifications

Item	Description
Operating Temperature	0 to 55 °C (32 to 131 °F)
Storage Temperature	-20 to 70 °C (-4 to 158 °F)
Operating Humidity	35 to 85% Relative Humidity, No condensation
storage Humidity	35 to 90% Relative Humidity, No condensation
Vibration Resistance - Direct Mounting	Conforms to IEC 68-2-6; 10 - 57 Hz: 0.75 mm Half Amplitude 57 - 150 Hz: 9.8 m/s <sup>2</sup> Acceleration Sweep Count for X, Y, Z: 10 times (80 min in each direction)
Vibration Resistance - DIN rail Mounting	Conforms to IEC 68-2-6; 10 - 57 Hz: 0.035 mm Half Amplitude 57 -150 Hz: 4.9 m/s <sup>2</sup> Acceleration Sweep Count for X, Y, Z: 10 times (80 min in each direction)
Shock Resistance	Conforms to IEC 68-2-27: 147m/s <sup>2</sup> Acceleration, Action Time: 11 ms 3 times in each direction X, Y, and Z
Noise Immunity	1000 Vp-p, 1microsecond, 30 - 100 Hz, tested by noise simulator
Dielectric Withstand Voltage	AC unit = 1500 V AC > 1 min, tested between all points, terminals and ground DC unit = 500 V AC > 1 min, tested between all points, terminals and ground.
Insulation Resistance	5 MΩ > at 500 V DC, tested between all points, terminals and ground
Ground	Class D (100 Ω or less)

### 3.4 PLC Mounting Arrangements

To prevent a rise in temperature, mount the units to walls. Never mount them to the floor or ceiling of an enclosure.

Below (left) Single row arrangement

Below (right) Double row arrangement using extension cable FX0N-65EC (650mm (25.59 inches); supplied separately).

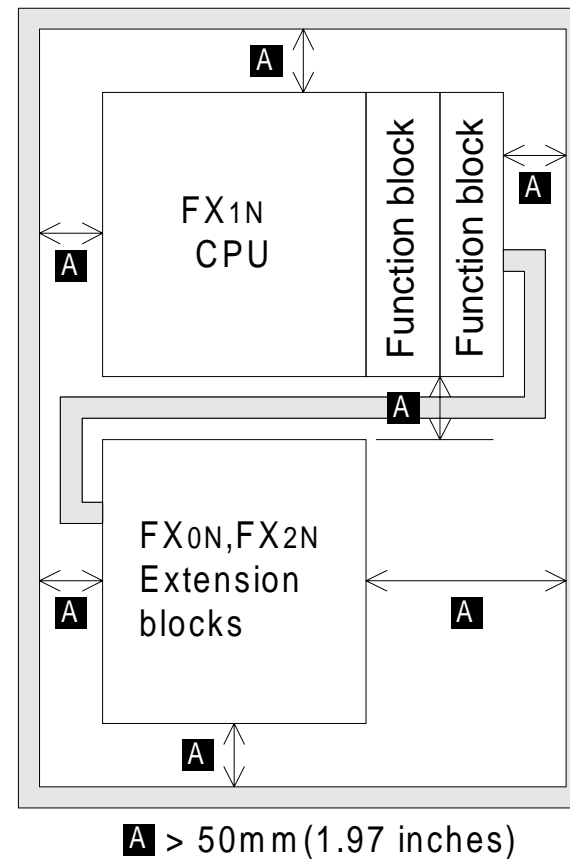
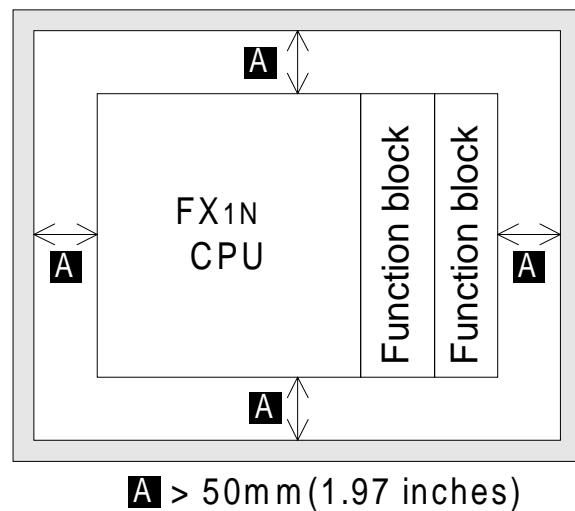



## Caution

- Units should not be installed in areas subject to the following conditions: excessive or conductive dust, corrosive or flammable gas, moisture or rain, excessive heat, regular impact shocks or excessive vibration.
- Take special care not to allow debris to fall inside the unit during installation e.g. cut wires, shavings etc. Once installation is complete remove the protective paper band, to prevent overheating.

## 3.5 DIN Rail Mounting

Units can be snap mounted to 35mm DIN rail (DIN EN 50022). To release, pull the spring loaded clips away from the rail and slide the unit up and off.

### 3.6 Direct Mounting

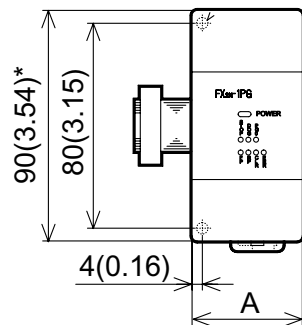

∅ = 4.5mm (0.18)

UNITS: mm (inches)

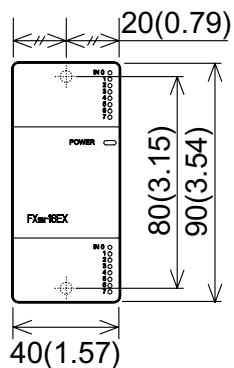

FX2N-16E□

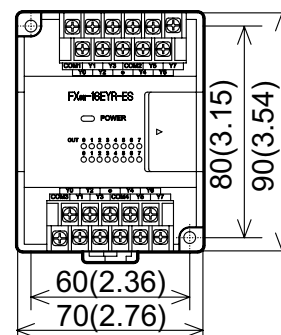

FX0N-16E□

UNITS: mm (inches)

MODEL	A	MODEL	A	MODEL	A
FX2N-4DA	55 (2.16)	FX2N-2DA	43 (1.69)	FX0N-32NT-DP	43 (1.69)
FX2N-4AD		FX2N-2AD		FX0N-232ADP	
FX2N-4AD-PT		FX2N-32CCL		FX0N-485ADP	
FX2N-4AD-TC		FX2N-16LNK-M		FX0N-8E□	
FX2N-16CCL-M	85(3.34)	FX0N-3A		FX0N-8E	

**Side view**

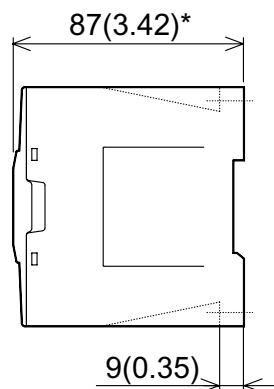

FX0N-232ADP is 68(2.68)

UNITS: mm (inches)

### 3.7 Termination at Screw Terminals

Cables terminating at a screw terminal of an FX<sub>0N</sub>, FX<sub>1N</sub> or FX<sub>2N</sub> product should be fitted with insulated crimp terminals, see example shown. Terminal screws should be tightened to between 0.5 to 0.8 N·m. Screw terminals must be secured to prevent a loose connection from causing a malfunction

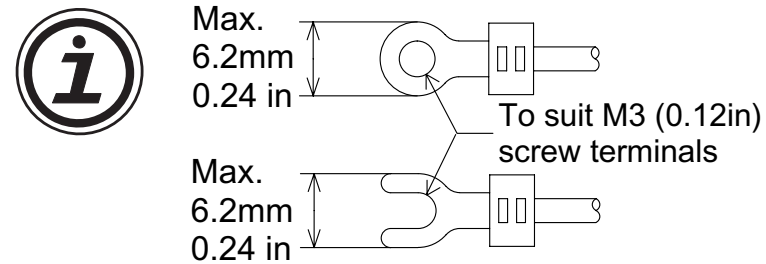

## 3.8 Wiring Techniques

The wiring of FX<sub>1N</sub> products has been designed to be safe and easy. If during the installation of these products or associated products concern is felt, please contact a professional electrician who is trained to the local and national standards applicable to the installation site.



### Wiring cautions

- Do not run input signals in the same multicore cable as output signals or allow them to share the same wire.
- Do not lay I/O signal cables next to power cables or allow them to share the same trunking duct. Low voltage cables should be reliably separated or insulated with regard to high voltage cabling.
- Where I/O signal lines are used over an extended distance consideration for voltage drop and noise interference should be made.
- Always ensure that mounted units and blocks are kept as far as possible from high-voltage cables, high-voltage equipment and power equipment.

## 3.9 Installing Optional Units

### 3.9.1 Special Function Boards

The following is a generic explanation of how to install a special function board to the FX1N PLC. For greater detail, specifications and wiring examples for each optional unit, please see the relevant product manuals.

Always make sure the power is turned off, before installing a special function board. Only one board can be used at any one time, do not try to stack multiple boards.

MODEL	USE WITH FX1N-5DM	USE WITH FX1N-EEPROM-8L
FX1N-232-BD	✓	Possible for program upload and download while the PLC is in the STOP mode.
FX1N-422-BD	✓	
FX1N-485-BD	✓	
FX1N-CNV-BD	✓	
FX1N-8AV-BD	✓	
FX1N-4EX-BD	✓	
FX1N-2EYT-BD	✓	
FX1N-2AD-BD	✗	✗
FX1N-1DA-BD	✗	✗

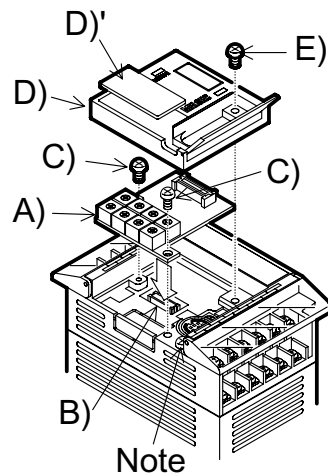

A) Special function or optional equipment board.

B) Optional equipment connector port.

C) M3 screw to secure board.

D) Top cover for board.

E) M3 screw to secure top cover.

Note: Do not remove this screw.

- Remove base unit top cover.
- Plug board A) into connector B).
- Fix board to base unit using screws C).
- Attach top cover for board D) removing section D)' to expose connector etc. (if applicable)
- Secure top cover with M3 screw E).

### 3.9.2 FX<sub>1N</sub>-5DM Display Module

Always make sure the power is turned off, before installing the 5DM.

- A) Top cover for DM
- B) Optional equipment connector port.
- C) M3 screw to secure top cover.

- Remove the base unit top cover.
- Attach the top cover for DM A), and secure with screw C) (if 5DM is to be permanently mounted)
- Plug in the 5DM at connector B)

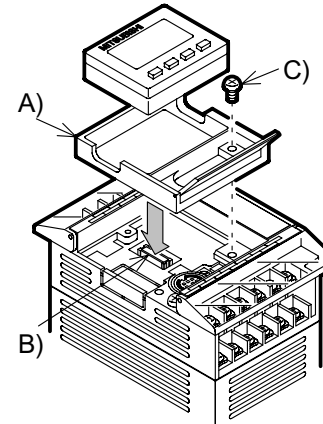

For further information please refer to the FX<sub>1N</sub>-5DM users manual.

<b>1</b>	<b>INTRODUCTION</b>
<b>2</b>	<b>TERMINAL LAYOUTS</b>
<b>3</b>	<b>INSTALLATION NOTES</b>
<b>4</b>	<b>POWER SUPPLY</b>
<b>5</b>	<b>INPUTS</b>
<b>6</b>	<b>OUTPUTS</b>
<b>7</b>	<b>DIAGNOSTICS</b>



## 4. Power Supply

### 4.1 Wiring Techniques

The wiring of FX1N products has been designed to be safe and easy. If during the installation of these product or associated products concern is felt, please contact a professional electrician who is trained to the local and national standards applicable to the installation site.

### 4.2 Wiring Cautions



- Do not run input signals in the same multicore cable as output signals or allow them to share the same wire.
- Do not lay I/O signal cables next to power cables or allow them to share the same trunking duct. Low voltage cables should be reliably separated or insulated with regard to high voltage cabling.
- Where I/O signal lines are used over an extended distance consideration for voltage drop and noise interference should be made.

### 4.3 Power Supply



When wiring AC supplies the “Live” cable should be connected to the “L” terminal and the “Neutral” cable should be connected to the “N” terminal. Do NOT connect the “Live” wire to the “N” terminal, the user might receive a dangerous shock on powerup.

When wiring DC supplies the “Live” cable should be connected to the “+” terminal and the “Neutral” cable should be connected to the “-” terminal. Do NOT connect the “Live” wire to the “-” terminal, the user might receive a dangerous shock on powerup.

## 4.4 Power Requirements

### AC Power Supply Units

	FX1N-14M	FX1N-24M	FX1N-40M	FX1N-60M
Power supply	100 - 240V AC +10%, -15%, 50-60Hz			
Max. allowable momentary power failure period	10ms; If less than 10ms, the PLC will continue operation.			
Fuse (size) rating	250V 1A		250V 3.15A (3A)	
In-rush current	100V AC - Max. 15A for 5ms 200V AC - Max. 25A for 5ms			
Power consumption *1	29W	30W	32W	35W

\*1 Includes the input current (7 or 5 mA per point).

### DC Power Supply Units

	FX1N-14M	FX1N-24M	FX1N-40M	FX1N-60M
Power supply	24V DC +20% ~ 12V DC -15% (28.8 ~ 10.2V DC)			
Max. allowable momentary power failure period	5ms; If less than 5ms, the PLC will continue operation.			
Fuse (size) rating	125 V 3.15A			
In-rush current	24V DC - Max. 25A for 1ms 12V DC - Max. 22A for 0.3ms			
Power consumption	13W	15W	18W	20W

## 4.5 Example Wiring

### 4.5.1 AC Power supply

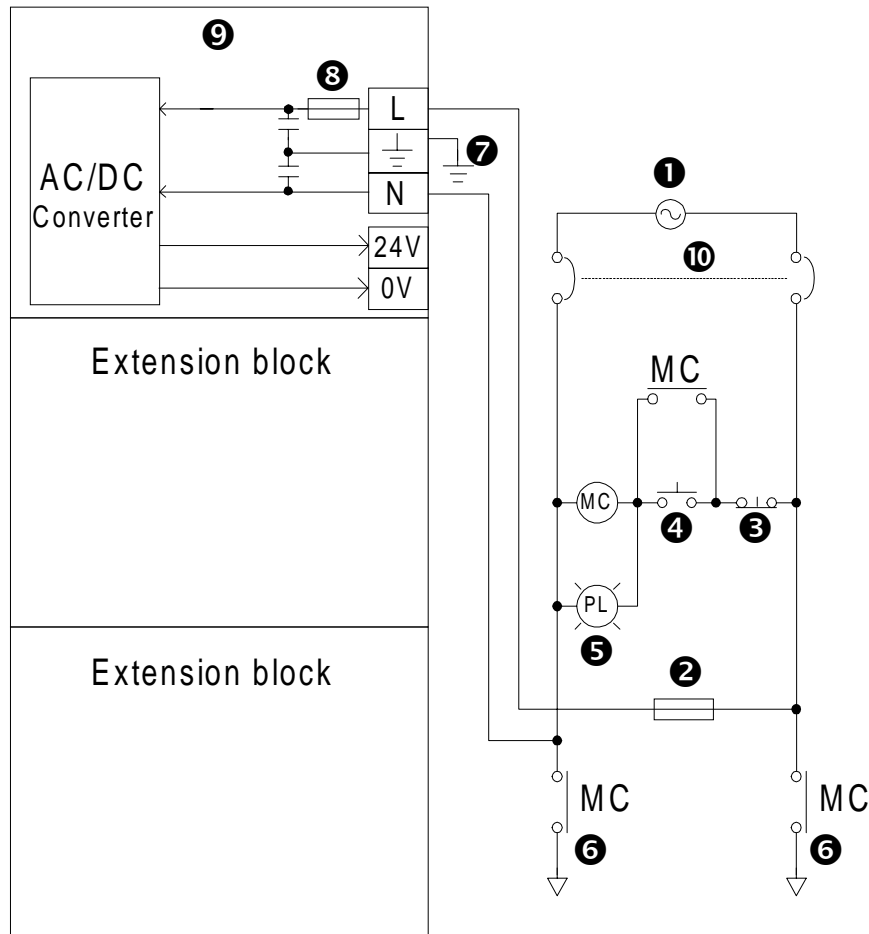

①	Power supply 100 - 240V AC +10% -15% 50 - 60 Hz
②	Circuit protector or Fuse
③	Emergency stop
④	Power supply switch
⑤	Power ON pilot indicator
⑥	Power supply for loads
⑦	Ground
⑧	Fuse
⑨	Main unit
⑩	Breaker

### 4.5.2 DC Power supply

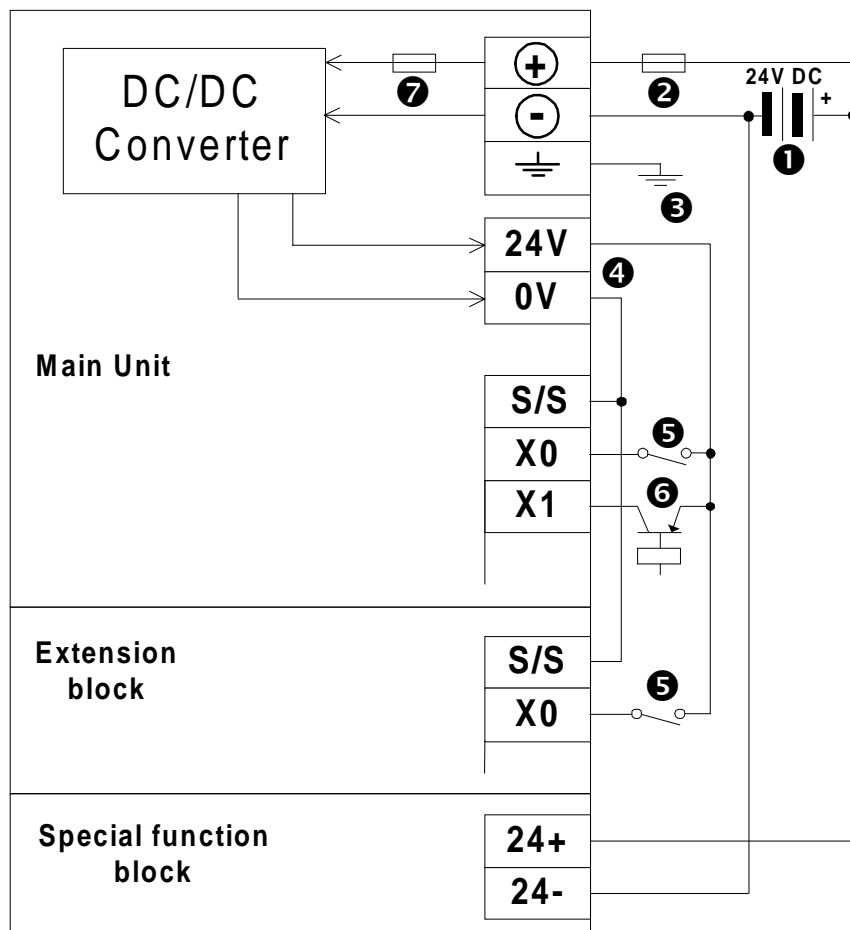

①	Power supply
②	Circuit protector or fuse
③	Ground
④	Input circuit power supply
⑤	Input switch
⑥	Input sensor (PNP open collector)
⑦	Fuse

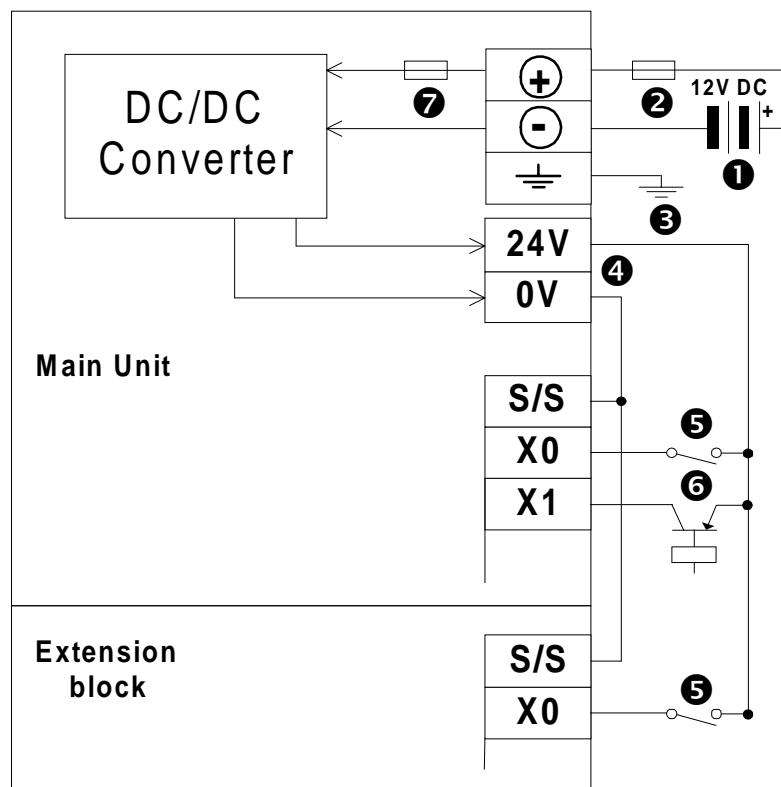

①	Power supply
②	Circuit protector or fuse
③	Ground
④	Input circuit power supply
⑤	Input switch
⑥	Input sensor (PNP open collector)
⑦	Fuse

## 4.6 Service Power supply

An AC powered FX1N can supply a service current of 24V DC at 400mA when used on its own and, when used with extension or special function blocks.

A DC powered FX1N does not have the capacity to supply a service current. However Additional extension blocks can be powered from the main unit power supply

## 4.7 Earthing / Grounding



Use a cable at least 0.2mm<sup>2</sup> (AWG24) to ground equipment. Ground resistance must be less than 100Ω (class D). Note that the ground cable must not be connected to the same ground as the power circuits. Grounding is recommended but if a proper ground cannot be provided, the PLC will still operate correctly without being grounded.

<b>1</b>	<b>INTRODUCTION</b>
<b>2</b>	<b>TERMINAL LAYOUTS</b>
<b>3</b>	<b>INSTALLATION NOTES</b>
<b>4</b>	<b>POWER SUPPLY</b>
<b>5</b>	<b>INPUTS</b>
<b>6</b>	<b>OUTPUTS</b>
<b>7</b>	<b>DIAGNOSTICS</b>



## 5. Inputs

### 5.1 24V DC input Specifications

		FX1N main unit, extension block		FX0N, FX2N Extension block
		X0 → X7	X10 → ∞	
Input voltage		24V DC ±10%		
Input current		24V DC, 7mA	24V DC, 5mA	24V DC, 5mA
Input switching current	OFF → ON	>4.5mA	>3.5mA	>3.5mA
	ON → OFF	<1.5mA		
Response time		10ms		
Variable response time		X000-X007 0-15ms		---
Circuit isolation		Photocoupler		
Operation indication		LED is lit		

### 5.1.1 Typical Wiring

A) Source

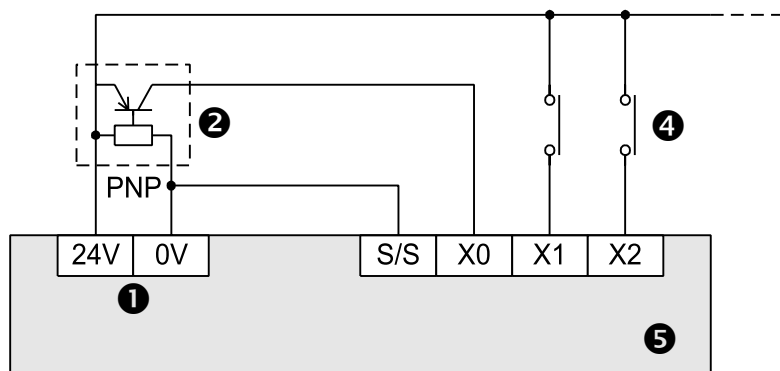

①	AC model - Service supply DC model - Input circuit power supply
②	PNP Sensor
③	NPN Sensor
④	Input Device Contact
⑤	Main unit

B) Sink

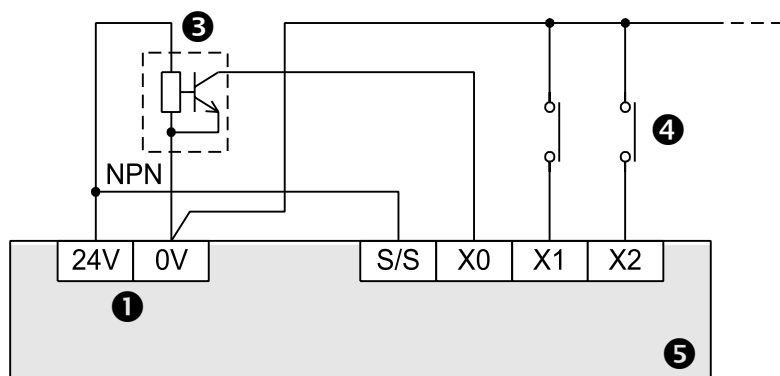

**Note:** When using a DC powered unit, the input circuit power supply should be used. If an external 24V DC supply is used the FX1N will not operate correctly.

When using an AC powered unit, an external 24V DC supply can be used.

### 5.1.2 Input Circuit Connection

#### FX<sub>1N</sub> Main unit

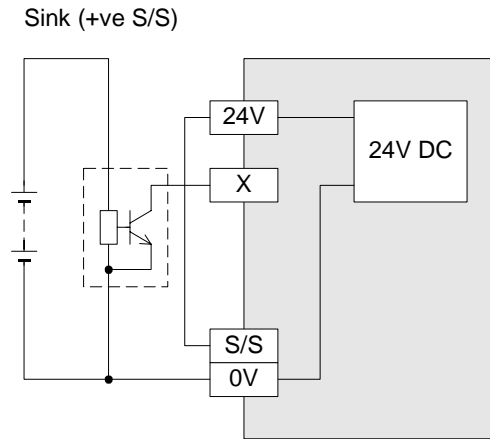
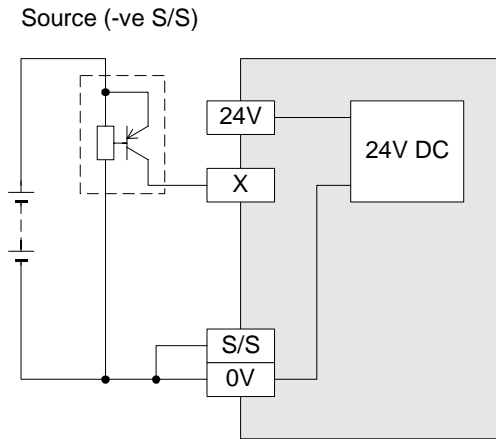

#### FX<sub>2N</sub> and FX<sub>0N</sub> Extension blocks

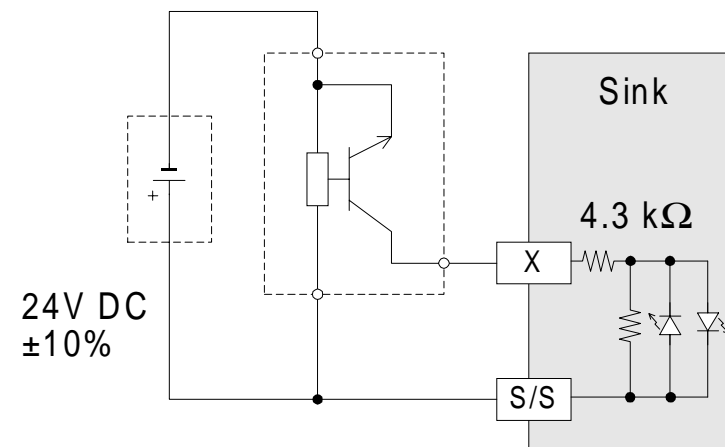
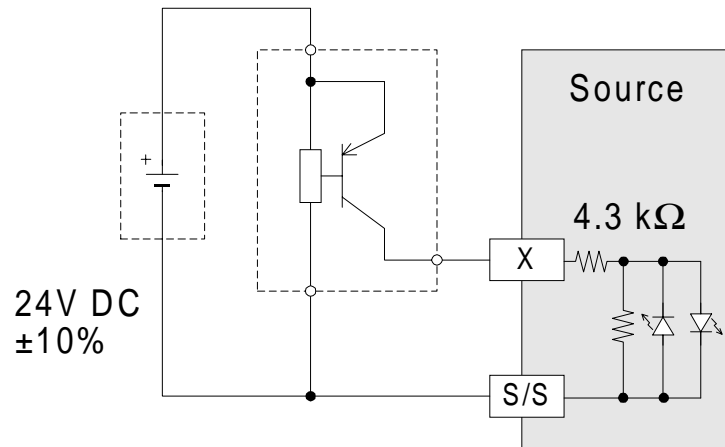

### 5.1.3 Diodes and Inputs Connected in Series

Vdrop across the diode Max. 4V

No more than 2 LEDs should be connected in series.

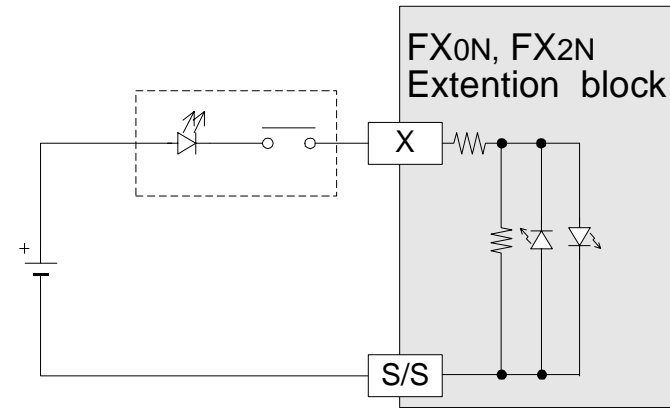
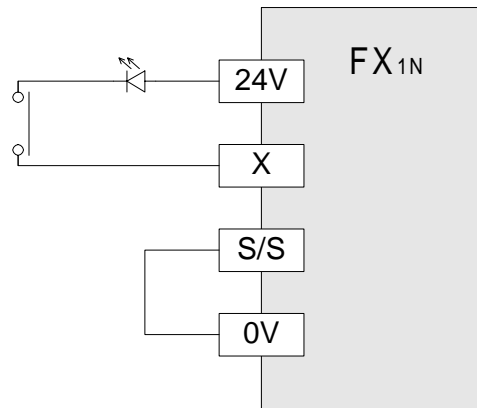

### 5.1.4 Resistors and Inputs Connected in Parallel

Parallel resistance  $R_p$ :  $FX_{1N} = 15k\Omega$ . If resistance  $R_p$  is less than the stated value, then add  $R_b$ . See equation 1 for  $R_b$  calculation.

Alternatively; Current leakage:  $FX_{1N} = 1.5mA$ . If the current leakage is greater than the stated value, then add  $R_b$ . See equation 2 for  $R_b$  calculation.

#### Parallel LED

$$\text{Eqn 1 : } R_b \leq \frac{4R_p}{15 - R_p}$$

$$\text{Eqn 2 : } R_b \leq \frac{6}{I - 1.5}$$

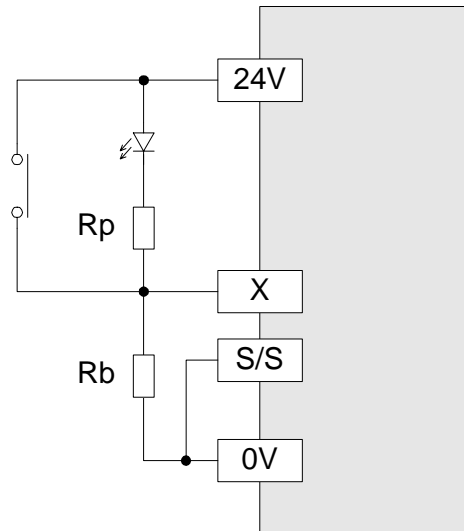

## 5.2 AC110V Input Extension Block

<b>Input voltage</b>	85-132V AC 50-60Hz
<b>Input impedance</b>	21k $\Omega$ /50HZ 18k $\Omega$ /60Hz
<b>Input current</b>	4.7mA 100V AC/50Hz 6.2mA 110V AC/60Hz
<b>OFF <math>\rightarrow</math> ON/ON <math>\rightarrow</math> OFF; input switching current</b>	80V 3.8mA/30V 1.7mA
<b>Response time</b>	25ms
<b>Circuit isolation / Operation indication</b>	Photocoupler/LED is lit

### 5.2.1 Input Circuit Connection

#### FX0N-8EX-UA1/UL

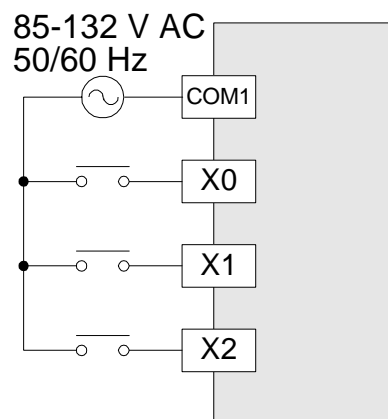

### 5.2.2 Programming Caution



When using 110V AC units, high speed counter and interrupt routines are not suitable for use due to the long 'ON/OFF' times. The following instructions are also not suitable.

FNC 52 MTR

FNC 56 SPD

FNC 72 DSW

## **MEMO**

<b>1</b>	<b>INTRODUCTION</b>
<b>2</b>	<b>TERMINAL LAYOUTS</b>
<b>3</b>	<b>INSTALLATION NOTES</b>
<b>4</b>	<b>POWER SUPPLY</b>
<b>5</b>	<b>INPUTS</b>
<b>6</b>	<b>OUTPUTS</b>
<b>7</b>	<b>DIAGNOSTICS</b>



## 6. Outputs

### 6.1 Output Specifications

Description		Relay Output	Transistor Output
Switched voltages (resistive load)		$\leq 240\text{V AC}, \leq 30\text{V DC}$	5-30V DC
Rated current / N points (resistive load)		2A/1 point, 8A/COM	0.5A/1 point, 0.8A/COM
Max. Inductive load		80VA, 120/240V AC	12W/24V DC
Max. lamp load (tungsten load)		100W (1.17A/85V AC, 0.4A/250V AC)	1.5W/24V DC
Minimum load		When supply voltage < 5V DC allow at least 2mA flow	-----
Response time (approx.)	OFF → ON	10ms	< 0.2ms; < 5 $\mu$ s (Y0,Y1 only)
	ON → OFF	10ms	< 0.2ms (I > 0.2A); <5 $\mu$ s (Y0,Y1 only)
Circuit isolation		By Relay	PhotoCoupler
Open circuit current leakage		-----	0.1mA/30V DC
Operation indication		LED is lit when coil is energized	

### 6.1.1 Relay Output Example

#### Typical Relay

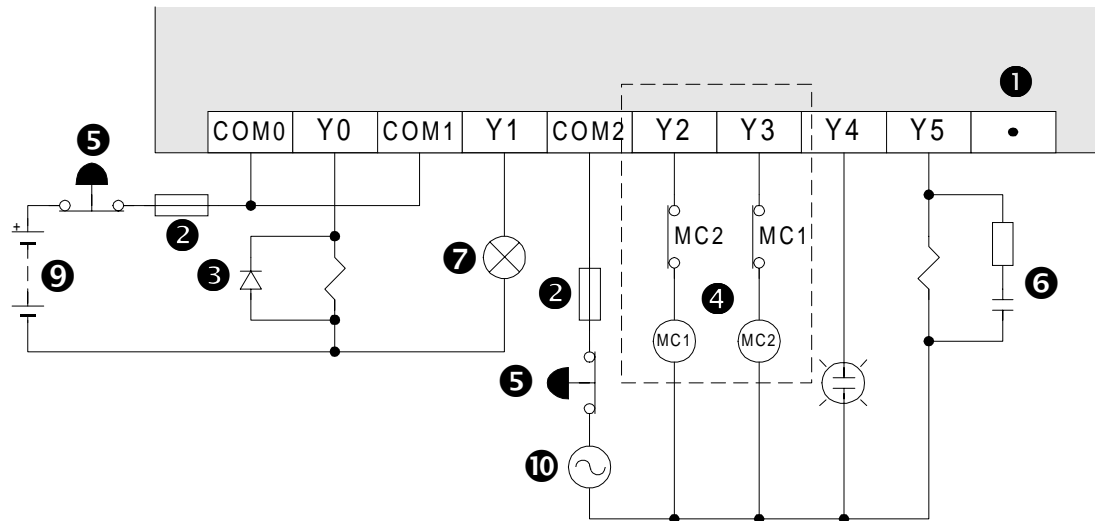

①	Do not use this terminal
②	Fuse
③	Surge absorbing Diode.
④	External Mechanical Interlock
⑤	Emergency Stop
⑥	Noise suppressor 0.1μF capacitor + 100-120Ω resistor Contactor
⑦	Valve
⑧	Incandescent Lamp
⑨	DC Power Supply
⑩	AC Power Supply

### 6.1.2 Reliability Tests



The test results in the table below were gathered from a 1 sec ON/OFF test cycle. Please note that the over current induced by in-rush greatly reduces the relay contacts service life. The rated life for an inductive AC load such as a contactor or solenoid valve is 500,000 operations at 20VA.

	20VA	35VA	80VA
Load capacity	0.2A/100VAC 0.1A/200VAC	0.35A/100V AC 0.17A/240V AC	0.8A/100V AC 0.4A/240V AC
Life of contact (cycles)	3,000,000	1,000,000	200,000
Example load (Mitsubishi contactor)	S-K10 ~ S-K95	S-K100 ~ S-K150	S-K180,S-K400

### 6.1.3 Response Times

OFF times increase as the load current decreases.

For improved response times use a 'dummy' resistor, see the figure below. If a response time of 0.5 ms or better is required when using 'light loads' use a 'dummy' resistor and ensure the signal line has a current greater than 60mA/24V DC

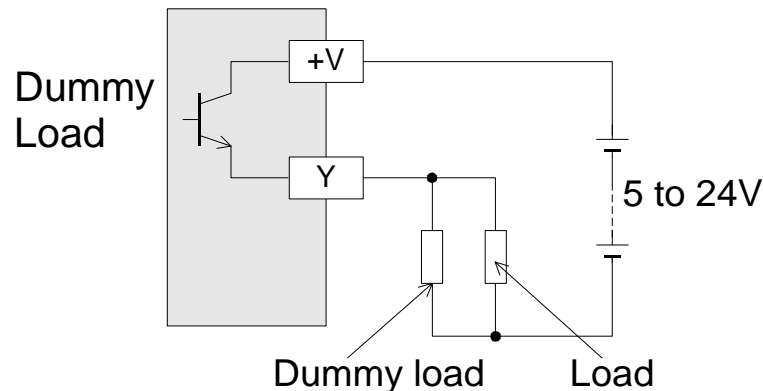

Y000 and Y001 are high speed response outputs with the following characteristics:

10 - 100mA at 5 - 24V DC, 100kHz maximum output signal.

If a high speed response is required, a current of 10 - 100mA must be used.

### 6.1.4 Transistor Output Example

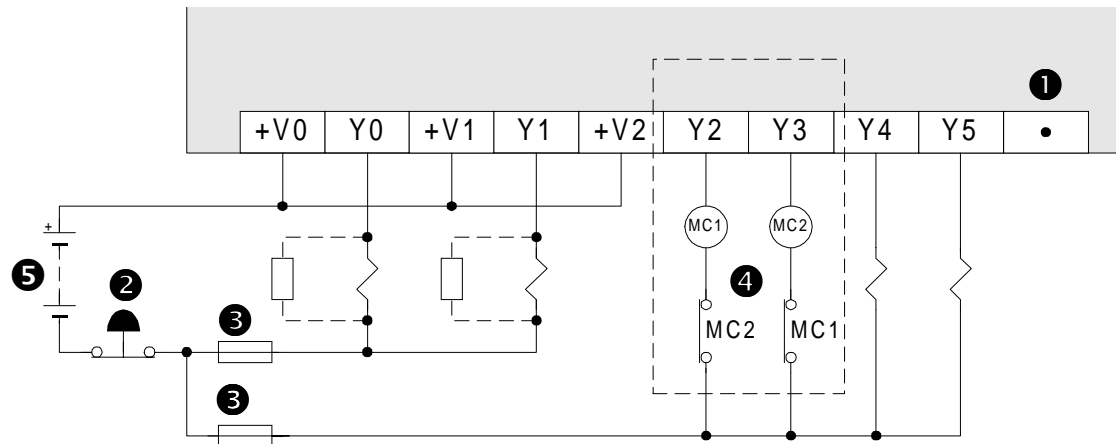

①	Do not use this terminal
②	Emergency Stop
③	Fuse
④	External Mechanical Interlock
⑤	DC Power Supply

### 6.1.5 Japanese Model Transistor Output

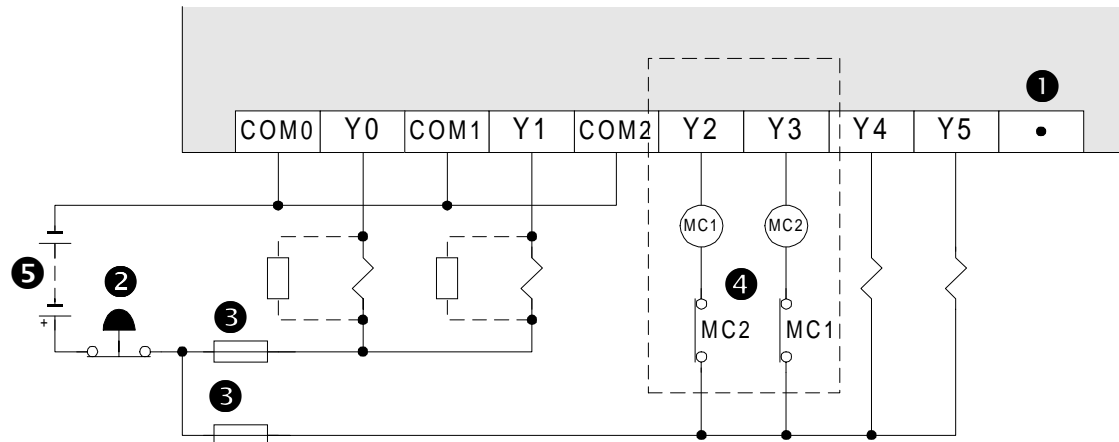

## 6.2 Applying Safe Loads



Ensure all loads are applied to the same side of each PLC output, see previous figures. Loads which should NEVER simultaneously operate (e.g. direction control of a motor), because of a safety critical situation, should not rely on the PLC's sequencing alone. Mechanical interlocks MUST be fitted to all safety critical circuits. (See preceding figure.)

## MEMO

<b>1</b>	<b>INTRODUCTION</b>
<b>2</b>	<b>TERMINAL LAYOUTS</b>
<b>3</b>	<b>INSTALLATION NOTES</b>
<b>4</b>	<b>POWER SUPPLY</b>
<b>5</b>	<b>INPUTS</b>
<b>6</b>	<b>OUTPUTS</b>
<b>7</b>	<b>DIAGNOSTICS</b>



## 7. Diagnostics

### 7.1 Preliminary Checks

POWER <input type="checkbox"/> RUN <input type="checkbox"/> ERROR <input type="checkbox"/>	Check power supply, ground and I/O cables are wired correctly.
POWER <input checked="" type="checkbox"/> RUN <input type="checkbox"/> ERROR <input type="checkbox"/>	Turn the power supply on. Check the power LED is lit. Down load a small test program into the PLC. Verify the program to ensure it has been written to the PLC correctly. Using the programming device, forcibly turn ON/OFF each output. Check the output LEDs for operation.
POWER <input checked="" type="checkbox"/> RUN <input checked="" type="checkbox"/> ERROR <input type="checkbox"/>	Put the PLC into RUN. Check the RUN LED is lit. Check the previously down loaded program works correctly. Once all checks are complete take the PLC out of run and turn OFF the power supply.
	During this testing stage take extreme care not to touch any live or hazardous parts.

## 7.2 ERROR LED ON (CPU ERROR)

POWER ■ RUN □ ERROR ■	<b>Fault</b> ERROR LED ON	<b>Remedy</b> Reset PLC. Power OFF,ON and trigger RUN input.	<b>Possible                  results</b>	LED OFF	Has the memory cassette been installed or removed while the units has still been powered?
				LED is lit	A

A	<b>Remedy</b> Power OFF	<b>Possible                  results</b>	LED is lit	B
	Disconnect earth/ ground terminal  Power ON		LED is flashing	Check for programming error. Ensure the earth/ ground cable is correctly rewired.

B	<b>Remedy</b> Possible program/scan time error. Check D8012 for program scan time, (units 0.2 ms must be less than 0.2 s, i.e data value <2000).	Possible results D8012 > D8000
---	--	-----------------------------------

### 7.3 Common Errors

- Corroded contact points at some point in an I/O line.
- An I/O device has been used outside its specified operating range.
- An input signal occurs in a shorter time period than taken by one program scan.

### 7.4 Maintenance

- Check interior temperature of the panel.
- Check panel air filters if fitted.
- Check for loosening of terminals or mounting facilities (due to vibration).

## 7.5 Operation and Error Flags

<b>M8004</b> (ref. 8004)	Error occurrence (ON when M8060-7 are ON)
<b>M8035</b>	Forced RUN mode
<b>M8036</b>	Forced RUN signal
<b>M8037</b>	Forced STOP signal
<b>M8039</b> (ref. D8039)	Constant scan mode

<b>M8061</b> (ref. D8061)	PC hardware error
<b>M8063</b> (ref. D8063)	Parallel link error
<b>M8064</b> (ref. D8064)	Parameter error
<b>M8065</b> (ref. D8065, D8069)	Syntax error
<b>M8066</b> (ref. D8066, D8069)	Program (circuit) error
<b>M8067</b> (ref. D8067, D8069)	Program execution error
<b>M8068</b> (ref. D8068)	Execution error latch

## 7.6 PLC Status Registers

<b>D8000</b> (default 200ms)	Watchdog timer
<b>D8001</b>	PLC version 26100 = FX 1N Version 1.00 26 = FX 1N, 100 = Version 1.00
<b>D8002</b>	Memory capacity 0008=8K steps
<b>D8003</b>	Memory type 02H=EEPROM protect switch OFF 0AH=EEPROM protect switch ON 10H=MPU memory
<b>D8004</b>	Error flag number 8060=M8060, (8060-8068)

## 7.7 Error Registers

<b>D8061</b>	Error code for PLC hardware error
<b>D8063</b>	Error code for parallel link fault
<b>D8064</b>	Parameter error code
<b>D8065</b>	Syntax error code
<b>D8066</b>	Program (circuit) error code
<b>D8067</b>	Program execution error code
<b>D8068</b>	Latched step number of execution error
<b>D8069</b>	Step number of errors associated with error flags M8065-M8067

## 7.8 Error Codes

<b>D8061</b>		Check cable connections
	0000	No error
	6101	RAM error
	6102	Operation circuit error
	6103	I/O bus error (M8069 = ON)
<b>D8062</b>		Check the programmer / PC connections
	0000	No error
	6201	Parity/overrun/framing error
	6202	Character error
	6203	Data sum check error
	6204	Data format error
	6205	Command error

<b>D8063</b>		Check both power and communications connections
	0000	No error
	6301	Parity/overrun/framing error
	6302	Character error
	6303	Data sum check error
	6304	Data format error
	6305	Command error
	6306	Watchdog timer error

## 7.9 Instruction List

		0	1	2	3	4	5	6	7	8	9
<b>000</b>	Program Flow	CJ	CALL	SRET	IRET	EI	DI	FEND	WDT	FOR	NEXT
<b>010</b>	Transfers, Comp	CMP	ZCP	MOV			BMOV			BCD	BIN
<b>020</b>	+ - x /, Logics	ADD	SUB	MUL	DIV	INC	DEC	WAND	WOR	WXOR	
<b>030</b>	Shift					SFTR	SFTL			SFWR	SFRD
<b>040</b>	Data Operation	ZRST	DECO	ENCO							
<b>050</b>	High Speed	REF		MTR	HSCS	HSCR		SPD	PLSY	PWM	PLSR
<b>060</b>	Handy Instructions	IST		ABSD	INCD			ALT	RAMP		
<b>070</b>	FX I/O Devices			DSW		SEGL				FROM	TO
<b>080</b>	FX Ser Devices	RS	PRUN	ASCI	HEX	CCD	VRRD	VRSC		PID	
<b>150</b>	Positioning						ABS	ZRN	PLSV	DRVI	DRVA
<b>160</b>	Real Time Clock	TCMP	TZCP	TADD	TSUB			TRD	TWR		HOUR
<b>170</b>	Special Comms							RD3A	WR3A		
<b>220</b>	In-line Compare					LD=	LD>	LD<		LD≠	LD≤
<b>230</b>		LD≥		AND=	AND>	AND<		AND≠	AND≤	AND≥	
<b>240</b>		OR=	OR>	OR<		OR≠	OR≤	OR≥			

	Symbol	FNC No	D	P
A	ABS	155		
	ABSD	062		
	ADD	020		
	ALT	066		
	AND□	232-238		
	ASCI	082		
B	BCD	018		
	BIN	019		
	BMOV	015		
C	CALL	001		
	CCD	084		
	CJ	000		
	CMP	010		
D	DEC	025		
	DECO	041		
	DI	005		
	DIV	023		
	DRVA	159		
	DRVI	158		
	DSW	072		

	Symbol	FNC No	D	P
E	EI	004		
	ENCO	042		
F	FEND	006		
	FOR	008		
	FROM	078		
H	HEX	083		
	HOUR	169		
	HSCR	054		
I	HSCS	053		
	INC	024		
	INCD	063		
	IRET	003		
L	IST	060		
	LDO□	224-230		
M	MOV	012		
	MTR	052		
	MUL	022		
N	NEXT	009		
O	OR	240-246		

	Symbol	FNC No	D	P
P	PID	88		
	PLSR	059		
	PLSV	157		
	PLSY	057		
	PRUN	081		
	PWM	058		
R	RAMP	067		
	REF	050		
	RD3A	176		
	RS	080		
S	SEGL	074		
	SFRD	039		
	SFTL	035		
	SFTR	034		
	SFWR	038		
	SPD	056		
	SRET	002		
SUB	021			

	Symbol	FNC No	D	P
T	TADD	162		
	TCMP	160		
	TO	079		
	TRD	166		
	TSUB	163		
	TWR	167		
	TZCP	161		

	Symbol	FNC No	D	P
V	VRRD	085		
	VRSC	086		
W	WAND	026		
	WDT	007		
	WOR	027		
	WR3A	177		
	WXOR	028		

	Symbol	FNC No	D	P
Z	ZCP	011		
	ZRN	156		
	ZRST	040		

## 7.10 Device List

Item		Specification	Remarks
Program capacity		8K steps	Provided by built in EEPROM memory
I/O configuration		Max hardware I/O configuration points 128, dependent on user selection (Max. software addressable Inputs 128, Outputs 128)	
Auxiliary relay (M coils)	General	384 points	M0 to M383
	Latched	1152 points (subset)	M384 to M1535
	Special	256 points	From the range M8000 to M8255
State relays (S coils)	Latched	1000 points	S0 to S999
	Initial	10 points (subset)	S0 to S9
Timers (T)	100 ms	Range: 0.1 to 3,276.7 s 200 points	T0 to T199
	10 ms	Range: 0.01 to 327.67 s 46 points	T200 to T245
	1 ms retentive	Range: 0.001 to 32.767 s 4 point	T246 to T249
	100 ms retentive	Range: 0.1 to 3,276.7 s 6 points	T250 to T255

Item		Specification	Remarks
Counters (C)	General	Range: 1 to 32,767 counts 16 points	C0 to C15 Type: 16 bit up counter
	Latched	184 points (subset)	C16 to C199 Type: 16 bit up counter
	General	Range: -2,147,483,648 to +2,147,483,647 counts 20 points	C200 to C219 Type: 32 bit bi-directional counter
	Latched	15 points (subset)	C220 to C234 Type: 32 bit bi-directional counter
High speed counters (C)	1 phase	Range: -2,147,483,648 to +2,147,483,647 counts Select upto six 1 phase counters with a combined counting frequency of 60kHz or less. Alternatively select 2 phase or A/B phase counters with counting frequency of 30kHz or less. Note all counters are latched	C235 to C240
	1 phase c/w start reset input		C241 to C245
	2 phase		C246 to C250
	A/B phase		C251 to C255

Item		Specification	Remarks
Data registers (D)	General	128 points	D0 to D127 Type: 16 bit data storage register pair for 32 bit device
	Latched	7872 points (subset)	D128 to D7999 Type: 16 bit data storage register pair for 32 bit device
	File	7000 points	D1000 to D7999 set by parameter in 14 blocks of 500 program steps Type: 16 bit data storage register
	Externally adjusted	Range: 0 to 255 2 points	Data is move from external setting potentiometers to registers D8030 and D8031)
	Special	256 points (inclusive of D8013, D8030 and D8031)	From the range D8000 to D8255 Type: 16 bit data storage register
	Index	16 points	V and Z Type: 16 bit data storage register
Pointers (P)	For use with CALL	128 points	P0 to P127
	For use with interrupts	6 points	I00o to I50o (rising trigger o = 1, falling trigger o = 0)
Nest levels		8 points for use with MC and MCR	N0 to N7
Constants	Decimal K	16 bit: -32,768 to +32,767 32 bit: -2,147,483,648 to +2,147,483,647	
	Hex. H	16 bit: 0000 to FFFF 32 bit: 00000000 to FFFFFFFF	

## **MEMO**



# HARDWARE MANUAL

FX<sub>1N</sub> SERIES PROGRAMMABLE CONTROLLERS



HEAD OFFICE: MITSUBISHI DENKI BLDG MARUNOUCHI TOKYO 100-8310 TELEX: J24532 CABLE MELCO TOKYO  
HIMEJI WORKS: 840, CHIYODA CHO, HIMEJI, JAPAN

---

JY992D89301F  
(MEE)

Effective April. 2001  
Specification are subject  
to change without notice.